



Steering Gear - 2.7L Diesel (57.10.01)

Special Service Tools



Ball joint separator (LRT-54-027)
205-754

Removal

All vehicles

1. Disconnect the battery ground cable. For additional information, refer to [Specifications](#) (Section 414-00)

2.  **WARNING:** Do not work on or under a vehicle supported only by a jack. Always support the vehicle on safety stands.

Raise and support the vehicle.

3. Remove the front wheels and tires.

4. **NOTE :**
Make sure the steering is in the straight ahead position.
Release the universal joint from the steering gear.

 Remove and discard the bolt.

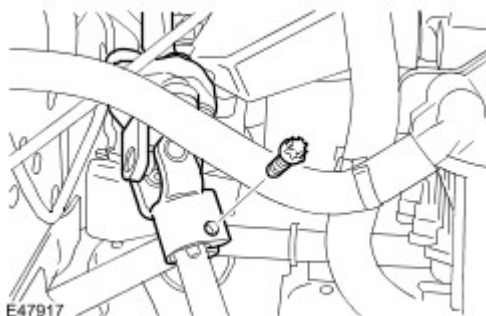

5.  **CAUTION:** Ensure the ball joint seal is not damaged. A damaged seal will lead to the premature failure of the joint.

Using the special tool, release both tie rod end ball joints.

- ▶ Loosen the tie-rod end ball joint retaining nut.
- ▶ Discard the nut.
- ▶ Repeat the above procedure for the other side.

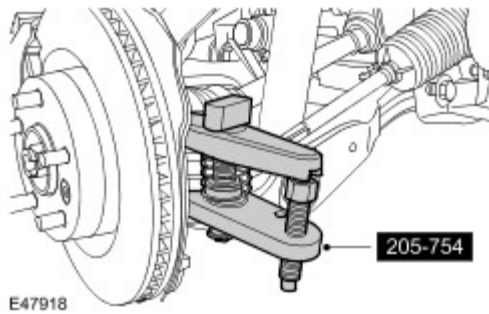

6. Remove the front RH and LH splash shields.

- ▶ Remove the 8 clips.

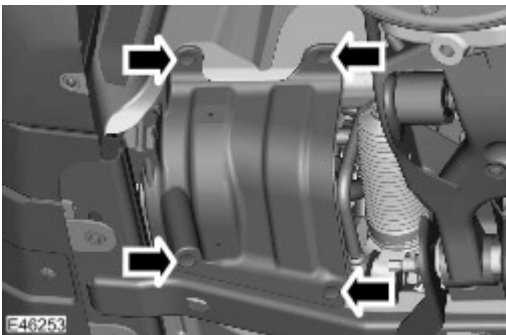

7. Remove the radiator access panel.

- ▶ Remove the 4 bolts.

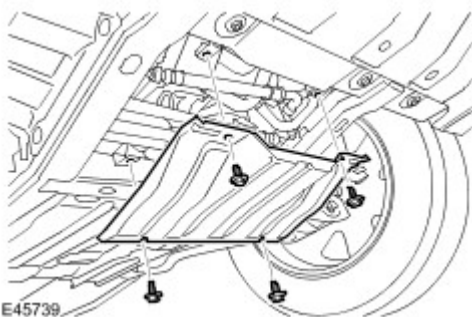

Vehicles with dynamic suspension

1. Release the dynamic response line supports.

- ▶ Remove the 2 nuts.
- ▶ Remove the 2 supports.



All vehicles

1. Release the power steering line support mount.
 - ▶ Remove the bolt.

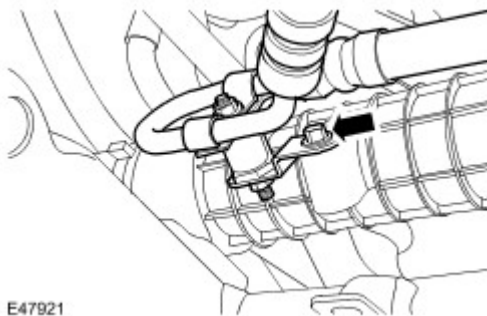

2.  **CAUTION:** Before disconnecting or removing the components, ensure the area around the joint faces and connections are clean. Plug open connections to prevent contamination.

NOTE :

Some fluid spillage is inevitable during this operation.

Disconnect the power steering fluid lines.

- ▶ Position a container to collect spillage.
- ▶ Remove the clip.
- ▶ Remove and discard the bolt.
- ▶ Discard the O-ring seals.

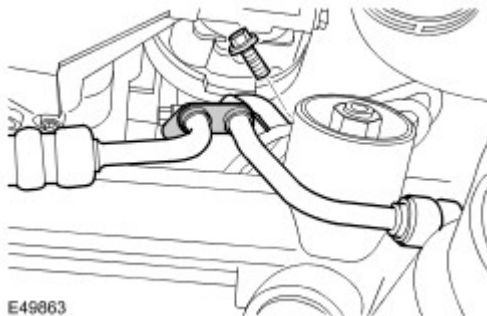

3. Disconnect the steering gear electrical connector.



4. Remove the steering gear.
 - ▶ Remove the 2 bolts and discard the nuts.

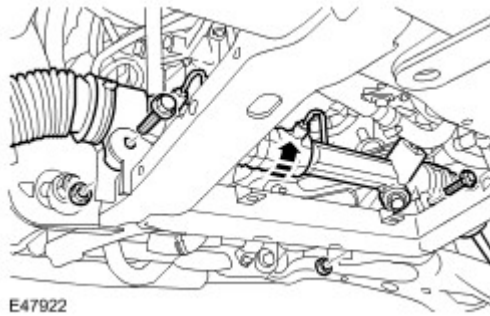

Installation

All vehicles

1. Clean the component mating faces.
2. Install the steering gear.
 - ▶ Tighten the bolts to 175 Nm (129 lb.ft).
3. Connect the electrical connector.
4. Install the power steering fluid lines.
 - ▶ Clean the component mating faces.
 - ▶ Install new O-ring seals.
 - ▶ Install the clip.
 - ▶ Tighten the bolt to 22 Nm (16 lb.ft).
5. Secure the power steering line support mount.
 - ▶ Install the bolt and tighten to 10 Nm (7 lb.ft).
6. Connect the universal joint to the steering gear.
 - ▶ Install new patchlock bolt and tighten to 30 Nm (22 lb.ft).

Vehicles with dynamic suspension

1. Install the dynamic response line supports.
 - ▶ Tighten the supports to 10 Nm (7 lb.ft).
 - ▶ Tighten the nuts to 10 Nm (7 lb.ft).

All vehicles

1. Install the radiator access panel.
 - ▶ Tighten the bolts to 10 Nm (7 lb.ft).
2. Install the splash shields.
 - ▶ Install the clips.
3. Connect the tie-rod end ball joints.
 - ▶ Clean the component mating faces.
 - ▶ Install new nuts and tighten to 70 Nm (52 lb.ft).
4. Install the front wheels and tires.
5. Connect the battery ground cable. For additional information, refer to [Specifications](#) (Section 414-00)
6. Fill and bleed the power steering system. For additional information, refer to [Power Steering System Filling and Bleeding](#) (Section 211-00)
7. Adjust the front wheel alignment.