

Cellular Phone

Cellular Phone Component Location

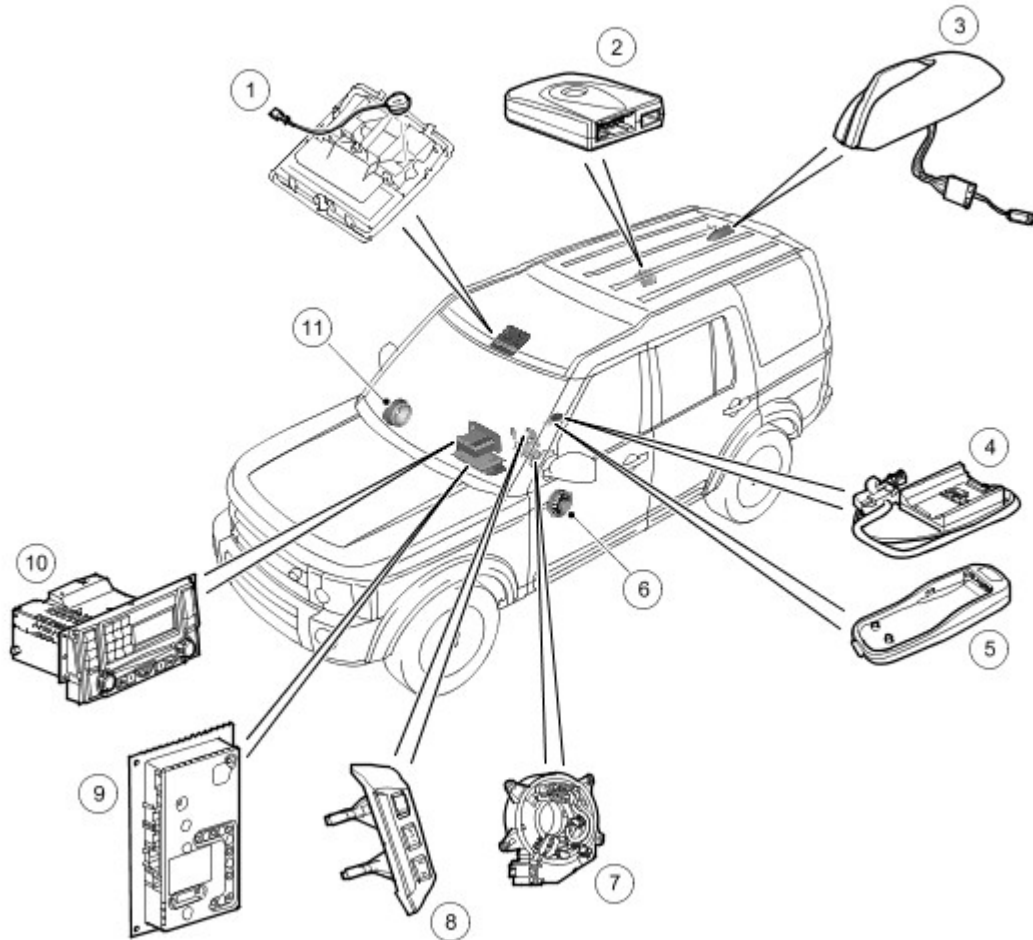

E48168

Item	Part Number	Description
1	-	Microphone
2	-	Transceiver Module (TM)
3	-	Cellular Phone Antenna
4	-	Base plate adaptor
5	-	Adaptor cradle
6	-	Speaker
7	-	Clock spring
8	-	Steering wheel switches
9	-	Amplifier
10	-	IHU
11	-	Speakers

Cellular Phone Control Diagram

NOTE :

A= Hardwired P= MOST

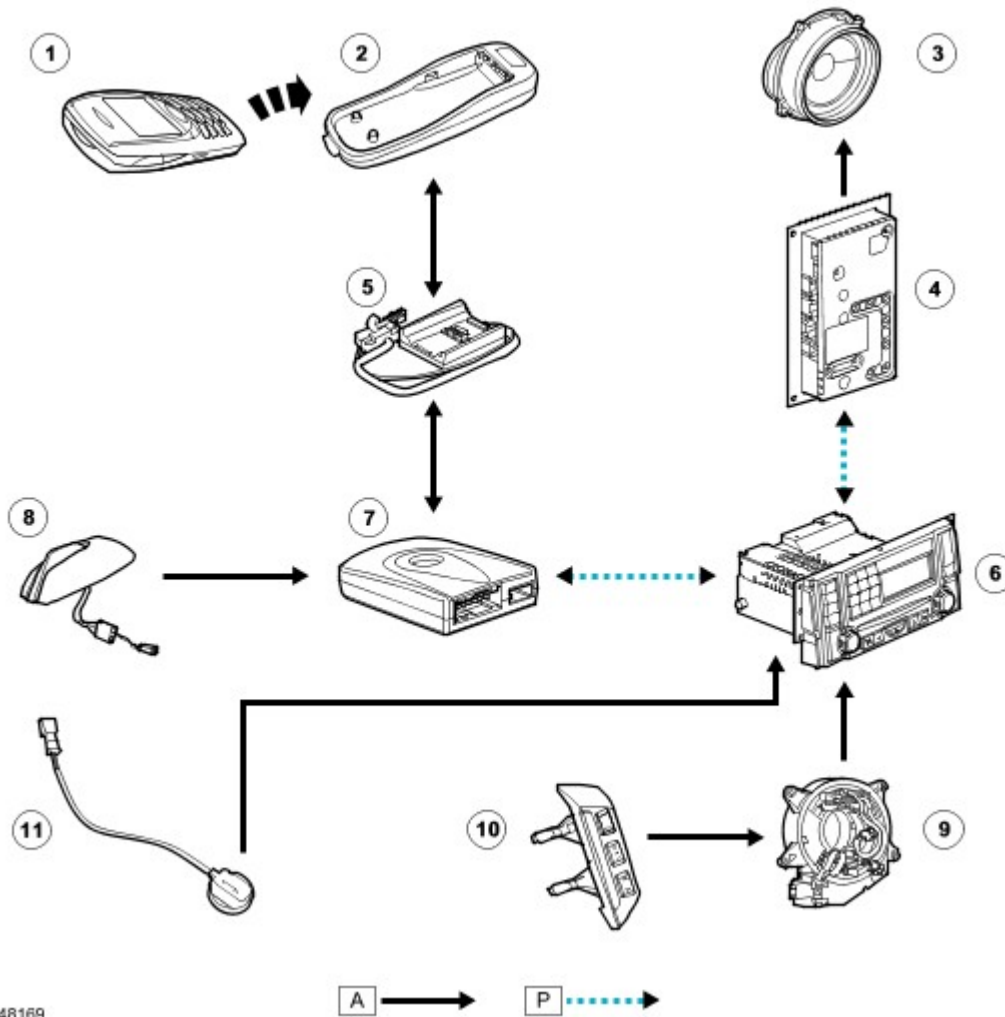

E48169

Item	Part Number	Description
1	-	Mobile handset
2	-	Adaptor cradle
3	-	Speakers
4	-	Audio amplifier
5	-	Base plate adaptor
6	-	IHU
7	-	Transceiver Module (TM)
8	-	Cellular Phone Antenna
9	-	Clock spring
10	-	Steering wheel switches
11	-	Microphone

CELLULAR PHONE SYSTEM

The cellular phone system comprises:

- Transceiver Module (TM)
- Base plate adaptor
- Telephone cradle
- Microphone
- Cellular Phone Antenna

The telephone system fitted to the vehicle allows the driver to dock their own handset to the vehicle hands free telephone system. This is achieved using an adaptor cradle which is telephone specific. This cradle is mated to a standard baseplate which in turn is connected to the TM. The TM is connected to the MOST ring for communication with the rest of the system. For additional information, refer to [Communications Network](#) (418-00 Module Communications Network)

Transceiver Module



E48172

The Transceiver Module (TM) is located in the rear RH quarter of the luggage compartment. The TM is the interface between the telephone and the Integrated Head Unit (IHU). The TM also contains the telephone voice recognition hardware and software.

Transceiver Module Connector Pin Out C2777

Pin No	Description	Input/Output
1 to 15	NC	-
16	Ignition	Input
17	Battery voltage	Input
18	Battery voltage	Input
19 to 32	NC	-
33	Ground	-
34	Ground	-
35	NC	-
36	NC	-
37	Cellular phone ear piece +	Output
38	Cellular phone ear piece -	-
39	Cellular phone Mic piece +	Input
40	Cellular phone Mic. piece -	-
41	Wake up signal (non Nokia phone in cradle)	Input
42	Wake up signal (Nokia phone in cradle)	Input
43	NC	-
44	Steering wheel push to talk button	Input
45	Transmit/receive to phone	Input/Output
46	Shield ground	-

47	Serial transmission + (Nokia F bus)	Output
48	Serial transmission - (Nokia F bus)	-
49	Serial receive + (Nokia F bus)	Input
50	Serial receive - (Nokia F bus)	-
51	Cradle ID signal	Input
52	Cradle voltage supply	Input
53	Phone charge ground	-
54	Battery charging voltage	Output

Microphone



E48173

A single microphone is used for hands-free telephone operation and for the voice recognition system. The microphone has an integrated noise suppression system for hands-free telephone use. The microphone is a standard directional type and is located in the front roof console.

Cellular Phone Antenna



E48085

The Cellular Phone Antenna is located in the roof mounted pod and is connected via a single coaxial cable to the TM. For additional information, refer to [Antenna](#) (415-02 Antenna)

Telephone Adaptor Cradle

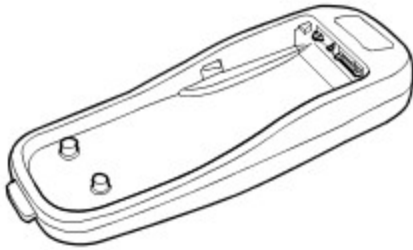

E48170

The telephone system allows for the use of different types/manufacturers handsets. This is achieved using a handset specific cradle which is mated to a standard base plate. The design of the adaptor cradle will vary to accommodate different types of phones.

Telephone Adaptor Base Plate

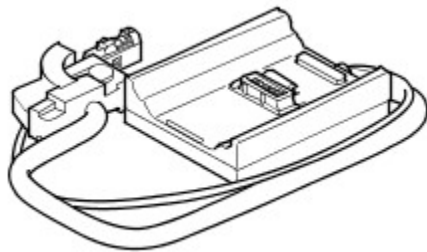

E48171

The base plate is located in the centre arm rest. The base plate is connected to the TM via a dedicated serial link.

TELEPHONE SYSTEM OPERATION

Telephone System

The telephone system can be operated from the IHU or via voice commands. The telephone system has the following functions:

- Receive a call
- Make a call
- Phone book
- Text message receive
- Telephone phone book download

The telephone system is accessed via the IHU. Once the phone is docked in the cradle it is possible to read/ download the phones own phone book to find a contact or phone number. A phone number can also be dialled into the key pad on the IHU.

Calls can be received or made by pressing the push to talk button on the steering wheel mounted controls.

SMS messages can only be made via the IHU with the handset in the cradle.

VOICE RECOGNITION

The Voice recognition system controls the following systems where fitted:

- Telephone
- Radio (inc satellite radio)

- CD / MP3 Changer
- Touch Screen Display (TSD)
- Note Pad
- Navigation

Voice control will not control Television or climate control system.

On vehicles without navigation system fitted the voice recognition software is held in the Transceiver Module (TM) and the microphone is hardwired directly into the TM. ON vehicles with navigation the voice recognition software is held in the navigation computer and the microphone is wired directly into the navigation computer and the TM. Vehicles with only no navigation system will have a slightly reduced functionality compared with vehicles that have navigation fitted as well as the phone.

The TM only houses voice recognition software for the telephone system.

Voice control enables the driver to activate important functions of the car telephone and navigation systems without needing to operate any controls manually. This allows the driver to concentrate fully on driving the vehicle. Whenever the driver issues one of the defined voice commands with the system active, the voice control system converts the command into a control signal for the telephone or navigation system. The system recognises which system the command is directed at and routes the direction accordingly. The driver is guided through the dialogues by announcements or questions.

Telephone

The telephone system allows the following to be accessed and controlled by the voice recognition function.

Dial Number

This allows the user to dial a number (up to 20 digits) by digit entry with editing facility and with number as built up and displayed on the instrument pack message centre. The maximum number of recognised digits to be entered in one go is 16.

Phonebook

This allows the user to store inputted phone numbers against inputted nametag. Nametags are user repeatable association names given to identify the numeric destination of the phone call.

This facility will allow 50 nametags with corresponding telephone numbers to be stored within the voice recognition Phonebook. This phonebook should not be confused with the phonebook held within the Sim card or mobile phone. The facility shall allow editing of the nametags and phonebook and also provide audible feedback of the recorded nametag. Where nametags are part of the audible Feedback the corresponding phone number shall be displayed in text form on the instrument pack message centre.

It is also possible to use the add name feature to enter a telephone number onto the IHU and then by voice recognition append a nametag and store this within the voice recognition phonebook.

Radio

The radio system allows the following to be accessed and controlled by the voice recognition function.

Radio On

This allows the user to switch on the radio function. "Radio On" switches the ICE system to Radio with the last station played.

Radio Tune

This allows the user to tune the radio the radio into the desired frequency and band.

Radio Presets

This allows the user to allocate frequency against a given band preset. The user must be tuned into the desired frequency and band prior to preset allocation. If a preset has already a stored frequency and band against that preset then the new frequency and band shall be allotted.

The Auto store feature instructs the radio to select the six strongest signals and allocate them against the auto store presets.

There shall be nine preset memory locations within each of the following band settings, FM, FMA, AM, AMA, MW, MWA and LW (only nine presets available for LW band therefore no Auto store available).

Voice commands will be available to allow the user to tune the radio to a given preset within the band that is currently tuned.

Radio Directory

This function allows the user to nametag the current frequency and band including satellite radio (SDARS). Nametags are user repeatable association names given to identify the frequency and band information thus allowing the radio to tune into the desired signal. This facility shall allow 20 nametags to be stored within the voice recognition. It shall be possible for the system to replay the whole of the directory with the ability to play or delete the stations announced. It should also be possible to individually delete nametags.

Where nametags are part of the audible Feedback the corresponding Frequency and Band shall be displayed in text form on the instrument pack message centre.

CD Changer

The CD changer system allows the following to be accessed and controlled by the voice recognition function.

The voice commands are standard control features with exception of controls that can be accessed on the steering wheel. Commands shall be available for up to 256 tracks on a CD. Text numeric format shall be 3 numbers i.e. track 6 is displayed as "006". MP3 Format discs have commands for Folder up/down. For additional information, refer to [Audio System](#) (415-01 Audio Unit)

Display

This function allows the user to change the TSD display mode by voice command.

Voice Recognition Settings

Voice Feedback On / Off

Allows the user to choose between having audible feedback or not for functions, other than some necessary functions, which must have audible feedback to operate.

Replay

The replay command requests the voice recognition system to repeat it's last dialogue response within a list in both audible and associated text feedback.

Notepad

The notepad function allows the user to record a series of 10 notes for up to 5 min.

The user shall be able to replay or delete the notes in the order that they were recorded. It shall also be possible to delete the whole notepad.

TMC

The TMC system is part of the navigation system and provides real time traffic information to the navigation system. The voice commands are On or Off. For additional information, refer to [Navigation System](#) (419-07 Navigation System)

TMC also offers Dynamic route guidance. This is also a voice operated on/off function.

BLUETOOTH®

The TM has Bluetooth® functionality. Bluetooth® allows the user to connect their own mobile phone (Bluetooth® enabled only) to the vehicle telephone system. Once connected the user can use the vehicle hands free functions system. The Bluetooth® system limits the functions available to those that are present in the Bluetooth® hands free profile. The available features include:

- Make/receive a call.
- Voice calls using the phones own voice tags (where set up).

Bluetooth® will not allow the following to be accessed via the IHU:

- SMS
- No signal strength indication in the IHU
- Phonebook download to the IHU
- Missed calls
- Last number redial
- Calls list

Prior to the Bluetooth® equipped phone being used on the vehicle hands free system the phone must be paired to the TM. The following describes the pairing process.

- Switch Bluetooth "ON" on the handset.
- The user initiates a search for other Bluetooth devices from the handset.
- The TM acknowledges the existence of the Bluetooth® phone.
- Land Rover appears in the handset available device list.
- The user selects Land Rover from the device list and the TM will attempt pairing.
- TM requests a PIN number from the phone.
- The user enters the phone PIN number (this will be supplied by the dealer or will be marked on the side of the TM, use the last four characters of the serial number).
- If the PIN number is correct the phone is paired with the TM and its details are stored in the TM EEPROM.
- If the PIN number is correct the phone is paired with the TM and the TM details are stored in the handset.

Once paired the TM will periodically check for stored Bluetooth® devices (approximately every 20 seconds). As this occurs the user will see a connection request on the handset and either accepts or declines the request. This request will only happen once per session.

Once the pairing procedure (assigning the mobile phone to the TM) has been completed the mobile handset will automatically connect to the vehicle system once they come into range (approximately 10 metres) and the vehicle ignition is in position II. The word Bluetooth® displays in the IHU to inform the driver that the phone is connected to the TM.

Each time a paired phone and TM come into range the TM will request connection to the phone. The user can accept or decline this request from the handset.

Up to eight Bluetooth® equipped phones can be paired with the TM. Phones can be de-registered/disconnected at any time by the user. Only one phone at a time can be used via the vehicle hands free system. If a phone is connected to the vehicle via the cradle, this phone will cancel out any Bluetooth® phone operation.

If the TM is replaced each phone that is paired with the original TM will have to be re-paired with the new TM.