

# Communications Network

## GENERAL

### Communication Network (Media Oriented System Transport MOST) Sheet 1 of 3

**NOTE :**

D= HS CAN Bus P= MOST

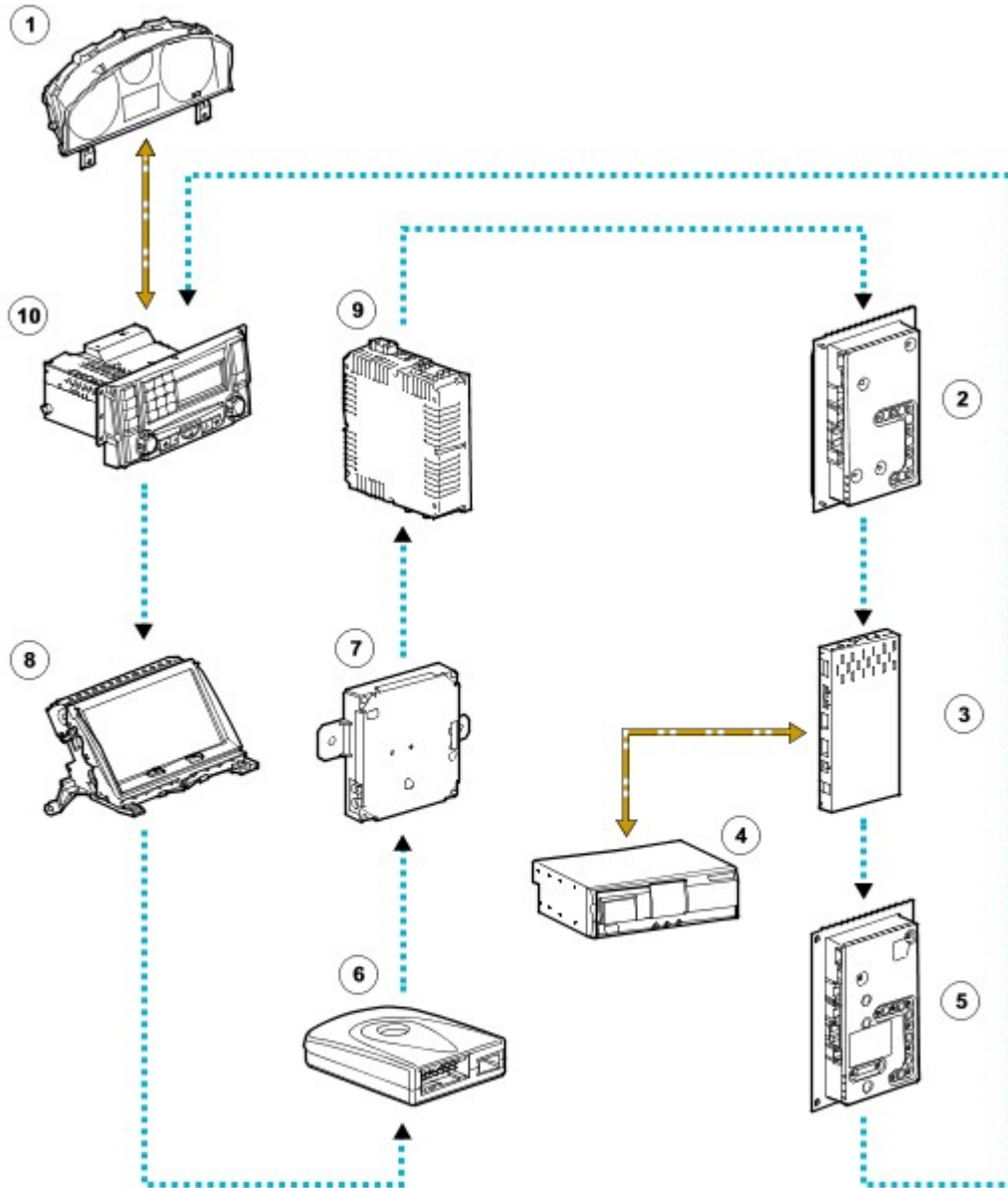

E43059



Item	Part Number	Description

1	-	Instrument cluster
2	-	Harman Kardom Logic 7 amplifier
3	-	Rear seat entertainment module
4	-	DVD autochanger
5	-	Harman Kardon amplifier
6	-	Transceiver module
7	-	Traffic Message Channel (TMC)
8	-	Touch Screen Display (TSD)
9	-	Television tuner module
10	-	Integrated Head Unit (IHU)

### Communication Network (CAN bus) Sheet 2 of 3

**NOTE :**

D= HS CAN Bus N= MS CAN Bus O= LIN Bus

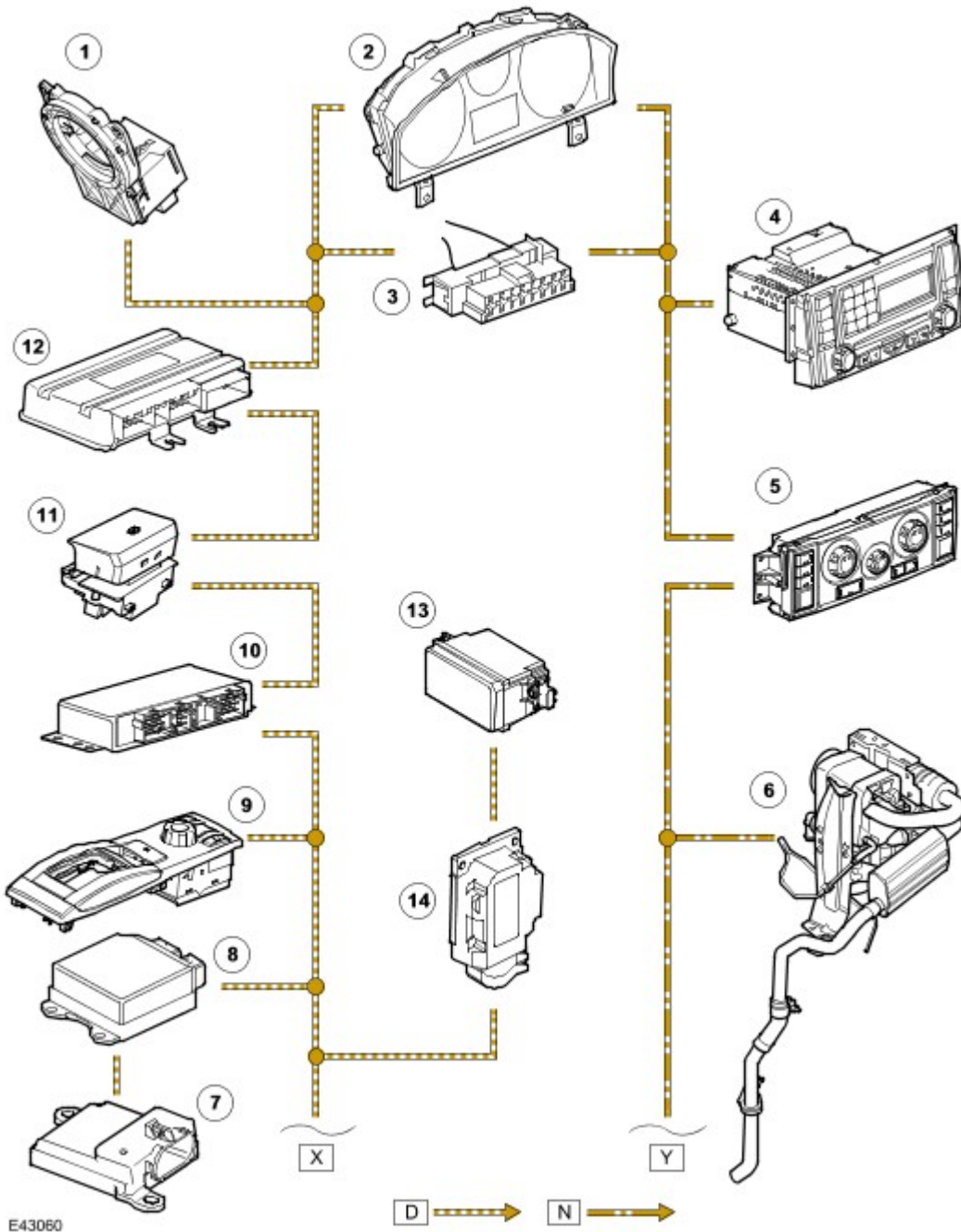

E43060

Item	Part Number	Description
1	-	Steering angle sensor
2	-	Instrument cluster
3	-	Diagnostic socket
4	-	Integrated Head Unit (IHU) or Head unit
5	-	Heating and ventilation control module
6	-	Fuel burning heater
7	-	Seat occupancy sensor (NAS only)
8	-	Restraints control module
9	-	Terrain Response™
10	-	Electronic rear differential control module

11	-	Electric park brake control module
12	-	Air suspension control module

### Communication Network (CAN bus) Sheet 3 of 3

**NOTE :**

D= HS CAN Bus N= MS CAN Bus O= LIN Bus

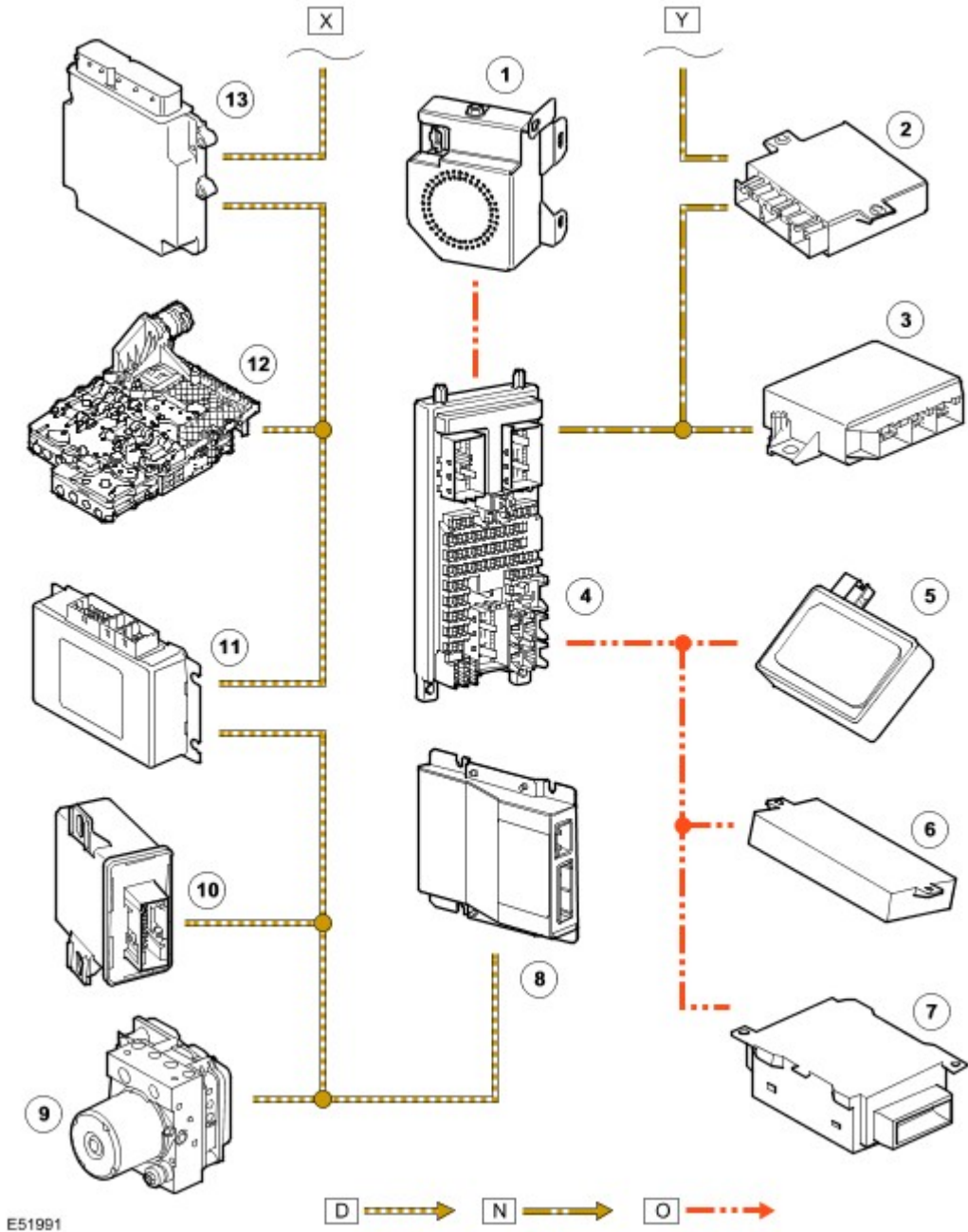

Item	Part Number	Description
1	-	Engine Control Module
2	-	Tyre pressure monitoring control module

3	-	Park Distance Control (PDC) module
4	-	Central Junction Box (CJB)
5	-	Rain sensor
6	-	Memory control module
7	-	Sunroof control module
8	-	Battery backed up sounder (BBuS)
9	-	ABS control module
10	-	Automatic Front Lighting System (AFS)
11	-	Transfer box control module
12	-	Transmission control module

A number of different types of data bus are incorporated into the vehicle wiring harnesses for the transmission of commands and information between ECU's. The bus configuration installed on a particular vehicle depends on the model and equipment level.

The available types of bus systems on the vehicle are:

- High speed Controller Area Network (CAN) bus
- Medium speed CAN bus
- Media Orientated System Transport (MOST) bus
- Gigabit Video Interface (GVIF)
- Local Interconnect (LIN) bus
- Security Local Interconnect (SLIN) bus

Bus	Baud rate	Protocol
High speed CAN	500 kbits/s	11898
Medium speed CAN	125 kbits/s	11898
MOST	24 Mbs	MOST Cooperation
GVIF	1.95 Gbps	Sony proprietary system
LIN	9.6Kbs	LIN consortium

## Controller Area Network (CAN)

The CAN bus is a high speed broadcast network where the ECU's automatically transmit information on the bus every few microseconds. The other buses are low speed networks which are mainly event driven, i.e. an electronic control module outputs a message only in response to a request message from another ECU or a hard wired input from a switch or sensor.

A twisted pair of wires are used for the CAN bus and single wires are used for all of the other buses. Bus wires can be repaired using crimped connections. The unwound length of CAN bus wires must not exceed 40 mm (1.6 in).

Two CAN busses are employed on the vehicle:

- Medium speed
- High speed

The medium speed bus connects the following control modules:

- Integrated Head Unit (IHU) or low line head unit
- Heating and ventilation control module
- Fuel burning heater
- Park distance control
- Tyre pressure monitoring control module
- Central junction box

The high speed bus connects the following control modules:

- Steering angle sensor
- Air suspension
- Electric park brake
- Electronic rear differential control module
- Terrain Response™
- Restraint control module
- Engine control module
- Transmission control module
- Adaptive front lighting system control module
- Antilock Braking System (ABS) control module

Both the medium and high speed CAN bus are connected to the Instrument cluster and the diagnostic socket at one end. The Medium speed bus terminates at the Central Junction Box (CJB), while the high speed bus terminates at the ABS control module.

Control modules are connected in either a loop , CAN in/ CAN out, or a spur configuration. Should a control module that is looped fail that bus system will fail at that point. Should a spurred control module fail the rest of the bus system will be unaffected by the faulty control module.

## Media Orientated System Transport (MOST)

The MOST bus uses a fibre optic cable to transport data and audio around the entertainment and information system. The fibre optic cable is arranged in a ring, with each unit on the bus having a MOST in and MOST out.

MOST is a synchronous network. A timing master supplies the clock and all other devices synchronize their operation to this clock. The timing master for the MOST network is the integrated head unit (IHU).

Key features of the MOST network are:

- Simple connectors
- Reduced cabling
- Support of asynchronous and synchronous data transfer
- Support for up to 64 devices
- High data transfer rate

When handling the MOST fibre optic cables the following safety precautions should be observed:

- The cable has a minimum bend radius of 25mm.
- It is advisable not to look directly into the connector of a live cable.
- The MOST cable cannot be repaired, replacement overlay harnesses will be available to replace damaged cables.

## Gigabit Video Interface (GVIF)

The GVIF bus is a Sony proprietary bus for the transmission of video between a transmitter device and a display device. In this instance it is used to transmit video from the navigation computer to the Touch Screen Display (TSD) only.

## Local Interconnect (LIN) bus

There are two LIN buses on the vehicle. One connects the Rain sensor, Sunroof and Memory seats to the central junction box and the other connects the BBUS to the central junction box.

The LIN bus has a master/ slave configuration. Within the master is stored a 'schedule table' which is a list of all the LIN frames or packets in order of which one gets sent when and how many times within a particular cycle. The Master sends out a header on the bus which will identify to the slaves whose turn it is to transmit a frame. The slave then fills the space after the header with the contents of the frame. The frame identifiers are all sourced from the LIN specification, and the frame identifiers are grouped by the size of the frame in bytes. All the LIN nodes are optional fit, consequently there is a different schedule table for each permutation and the Bus master switches between these based on the information held within the car configuration file. The CJB also acts as a bi-directional gateway between the MS-CAN bus and the LIN bus by passing signals between the two buses.

The bus is a single wire and operates at 9.6Kbs. The protocol used on the LIN bus is defined by the LIN consortium.

## **Diagnostic Socket**

The diagnostic socket allows the transfer of information between the vehicle Electronic Control Modules and T4 on the high or medium speed CAN bus, or indirectly via the instrument pack. The diagnostic socket is located in the lower instrument panel closing panel, on the drivers side below the steering column.