

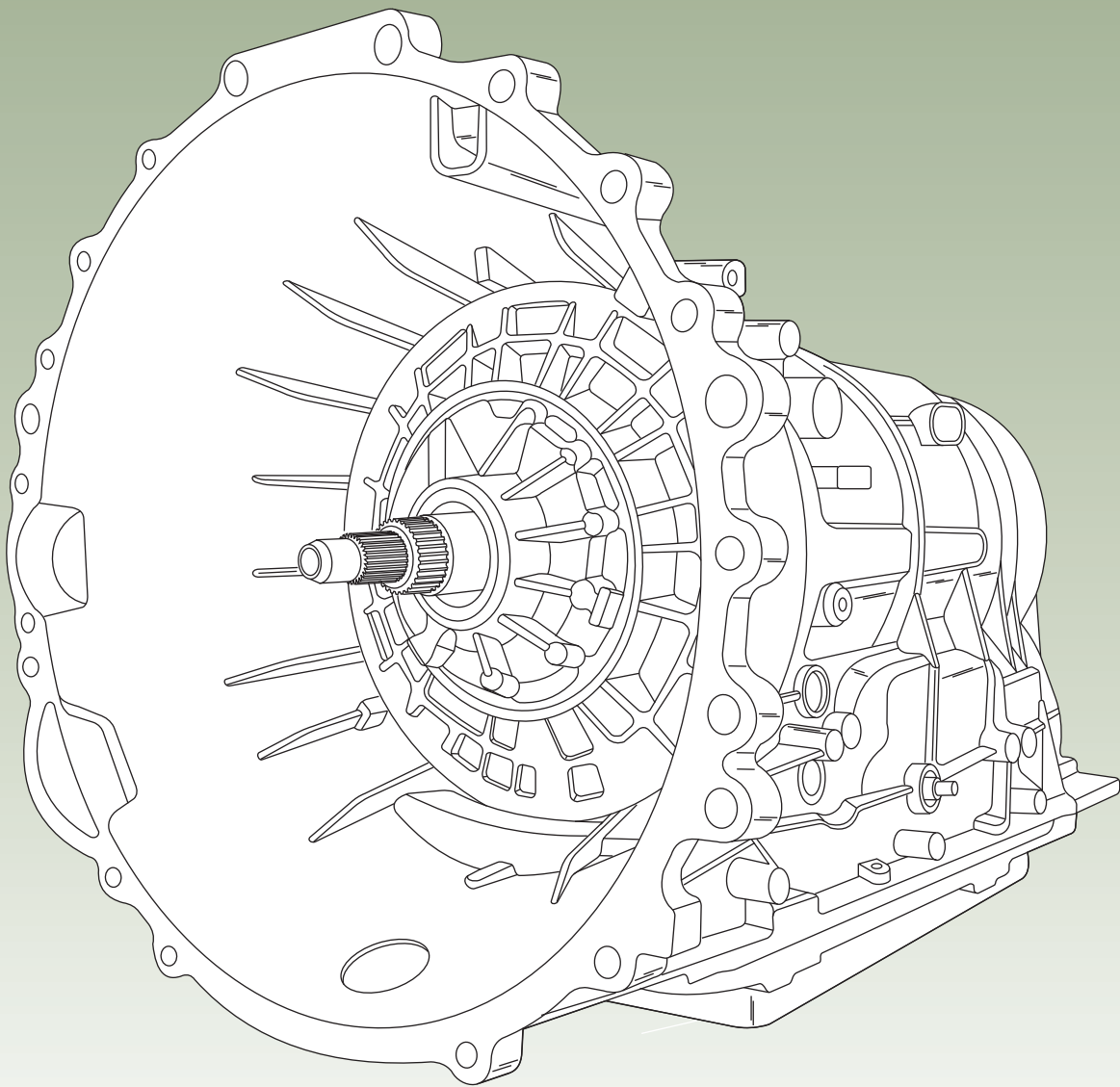

*Audi/Jaguar/BMW*  
*"ZF6HP26"*

# *TECHNICIANS DIAGNOSTIC GUIDE*



*Technical*

**SERVICE INFORMATION**

T  
O  
Y  
O  
T  
A  
/  
L  
E  
X  
U  
S  
  
U  
1  
4  
0  
/  
2  
4  
0  
-  
E

T  
O  
Y  
O  
T  
A  
/  
L  
E  
X  
U  
S  
  
U  
1  
4  
0  
/  
2  
4  
0  
-  
E

T  
O  
Y  
O  
T  
A  
/  
L  
E  
X  
U  
S  
  
U  
1  
4  
0  
/  
2  
4  
0  
-  
E

T  
O  
Y  
O  
T  
A  
/  
L  
E  
X  
U  
S  
  
U  
1  
4  
0  
/  
2  
4  
0  
-  
E

T  
O  
Y  
O  
T  
A  
/  
L  
E  
X  
U  
S  
  
U  
1  
4  
0  
/  
2  
4  
0  
-  
E

T  
O  
Y  
O  
T  
A  
/  
L  
E  
X  
U  
S  
  
U  
1  
4  
0  
/  
2  
4  
0  
-  
E

## THE ZF6HP26 TRANSMISSION BMW PRELIMINARY INFORMATION

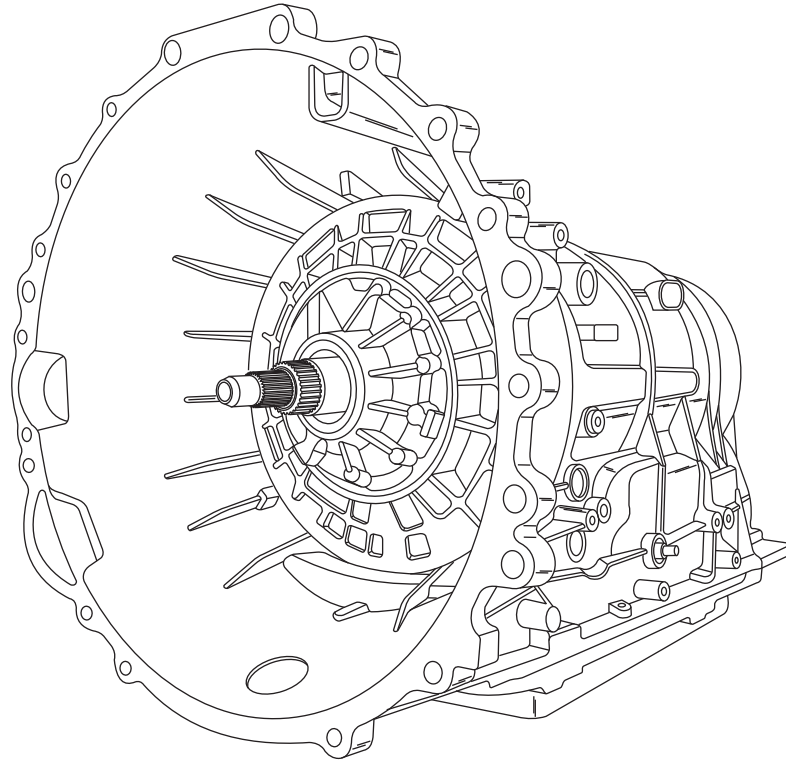

MAKE	MODEL	YEAR1	ENGINE	CODE
AUDI	A8	2003-On	4.2, 6.0L	ZF6HP26A
AUDI	S4	2004-05	4.2L	ZF6HP26A
AUDI	S6	2000-On	5.2L	ZF6HP26
BENTLEY	Brooklands	2008-On	V8, 6.8L Twin Turbo	ZF6HP26
BENTLEY	Continental Flying Spur	2005-On	W12, 6.0L	ZF6HP26
BENTLEY	Continental GT	2003-On	W12, 6.0L	ZF6HP26
BENTLEY	Continental GTC	2006-On	W12, 6.0L	ZF6HP26
BMW	335i	2008-On	3.0L Twin Turbo	ZF6HP26
BMW	530d, xd	2004-On	3.0L TD	ZF6HP26
BMW	530i, xi	2004-07		ZF6HP26
BMW	535d	2004-On	3.0L TD	ZF6HP26
BMW	535i, xi	2008-On	3.0L Twin Turbo	ZF6HP26
BMW	540i	2006-On	4.0L	ZF6HP26
BMW	545i	2004-05		ZF6HP26
BMW	550i	2006-On	4.8L 6 spd.	ZF6HP26
BMW	550xi	2006-On	4.8L AWD	ZF6HP26
BMW	630i, Ci	2004-On	3.0L	ZF6HP26
BMW	645Ci, 645Li	2004-On	4.4, 4.8L	ZF6HP26
BMW	650i	2006-On	4.8L	ZF6HP26
BMW	730d, Ld	2002-On	3.0L TD	ZF6HP26
BMW	730i, Li	2004-On	3.0L	ZF6HP26
BMW	740i, Li	2002-On	4.0L	ZF6HP26
BMW	745d	2002-On	4.4L D	ZF6HP26
BMW	745i, 745Li	2002-05	V8, 4.4L	ZF6HP26
BMW	750i, Li	2006-On	4.8L	ZF6HP26
BMW	X5	2004-On	3.0, 4.4, 4.8L	ZF6HP26A
FORD	Falcon	2005-On		ZF6HP26
HYUNDAI	Genesis	2008-On	3.8, 4.6L	ZF6HP26
JAGUAR	S type	2003-On	3.0, 4.2L	ZF6HP26
JAGUAR	Super V8	2008-On	4.2L SC	ZF6HP26
JAGUAR	X type	2002-07	2.5, 3.0L	ZF6HP26
JAGUAR	XF	2009-On	4.2L SC	ZF6HP26
JAGUAR	XJ Vanden PLAS	2004-On	V8, 4.2L	ZF6HP26
JAGUAR	XK8	2003-On	V8, 4.2L	ZF6HP26
JAGUAR	XKR	2003-On	V8, 4.2L	ZF6HP26
LAND ROVER	LR3	2005-On	V6, 4.0L, V8, 4.4L	ZF6HP26
LAND ROVER	Range Rover	2005-On	V8, 4.2, 4.4L	ZF6HP26
MASERATI	Gran Turismo	2007-On	V8, 4.2L	ZF6HP26
MASERATI	Quattroporte	2004-On	V8, 4.2L	ZF6HP26
PORSCHE	Cayenne	2002-06	3.2, 4.5L	ZF6HP26

Copyright © 2008 ATSG

Figure 1  
Automatic Transmission Service Group

## THE ZF6HP26 TRANSMISSION

The ZF Company has produced several 6 speed transmissions which are being used in car lines such as Jaguar, BMW, Volkswagen and Audi.

Currently they have the 6HP19, the 6HP19FL and FLA, the 6HP26 and 6HP26A61, the 6HP32 and 32A. Although there are similarities among these units, they also have very significant differences. As a result, this short presentation will only be in regard to the 6HP26.

ZF6HP26 transmission within itself has several versions so as to accommodate the different car manufacturers and various engines they are fitted with, but the basic design and function of the transmission are the same.

*The fundamental design that will be seen in all versions are as follows:*

1. A torque converter with lockup clutch
2. 3 driving clutches referred to as clutch A, B and E.
3. 2 brake clutches referred to as clutch C and D.
4. A Lepelletier Planetary Gear Train
5. A Mechatronics Module

*The differences that will be observed with regard to the various versions are as follows:*

1. Power output and torque characteristics
2. Torque converter configuration
3. Clutches with different number of steel discs and lined plates
4. Lepelletier planetary gear train with a different number of planet gears
5. Valve body

**Mechanically**, the six forward speeds and reverse are accomplished through the use of what is known as a Lepelletier planetary gear train, 3 driving clutches and 2 holding clutches as seen in the application chart displayed in Figure 2.

**Electrically and hydraulically**, this gear box is controlled by what is known as "The Mechatronic Module." This is a combination of a transmission control module and valve body configured as one unit. In other words, the computer for the transmission is mounted onto the valve body and is submerged in transmission fluid. As a result of this Mechatronic Module technology, the pass through case connector from the module to the vehicle harness will basically contain only power, ground and CAN Bus network wiring.

Another major deviation from the standard operational procedures we are familiar with in automatic transmissions is that with some models, there is not a mechanical connection from a selector lever to the manual valve. Instead, the driver makes a request of the desired gear engagement either through buttons or paddles or a shift lever, which then sends an electrical signal over the CAN bus network to the TCM. The TCM implements those commands taking into account various ambient conditions. This information is also used over the network so that the relevant gear positions are illuminated in the instrument cluster.

With the elimination of the conventional gear shift mechanism for a "shift by wire" strategy, there becomes a need for safety enhancements associated with this type system. One such example would be that when the ignition key is removed, it will automatically initiate a park engagement. Another is a hard wire serial data link from the various styles of selector lever input signals to the Mechatronic as a redundancy signal to the CAN bus input. Any errors will be reported and displayed either in the instrument cluster or via a scanner. And there will be the need for a mechanical emergency park release.

In addition to six forward speeds, there is a **torque converter clutch** strategy to further enhance fuel economy. Most of these converters use a two-friction surface lockup clutch design which is slip- controlled in all forward gears (1 through 6).

ZF6HP26  
INTERNAL COMPONENT IDENTIFICATION AND LOCATION

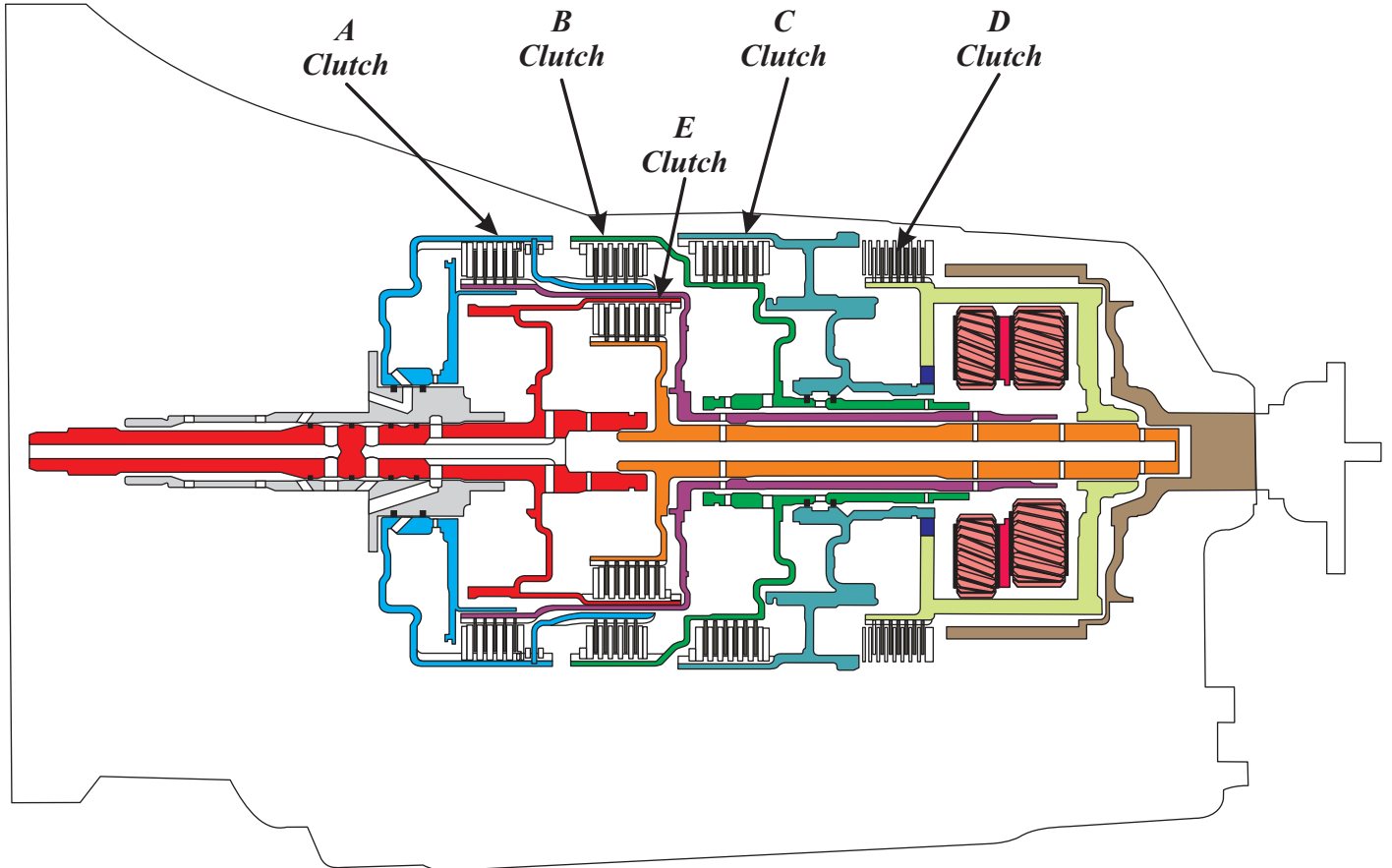

COMPONENT APPLICATION CHART

RANGE	A Clutch	B Clutch	E Clutch	C Clutch	D Clutch	Torq Conv Clutch	GEAR RATIO
Park					Applied		
Reverse		Applied			Applied		3.403
Neutral					Applied		
"D"-1st	Applied				Applied		4.171
"D"-2nd	Applied			Applied		Applied*	2.340
"D"-3rd	Applied	Applied				Applied*	1.521
"D"-4th	Applied		Applied			Applied*	1.143
"D"-5th		Applied	Applied			Applied*	0.867
"D"-6th			Applied	Applied		Applied*	0.691

\* TCC IS AVAILABLE IN 2ND THRU 6TH GEAR, BASED ON THROTTLE POSITION, FLUID TEMP AND VEHICLE SPEED.

Figure 2  
Automatic Transmission Service Group

## THE ZF6HP26 TRANSMISSION

The converter clutch will not engage until transmission fluid temperature has reached above 96°F (35°C). Slip control is also dependent upon various factors such as engine load, vehicle speed, the selected gear shift program and transmission fluid temperature.

When conditions are right, the slip control from 1st through 6th occurs in the XE program meaning eXtreme Economy. The general factors that initiate the XE program is speeds below 20 mph (30 km/h) with a load requirement below 50%. The clutch will disengage when the load requirement exceeds 50%.

The converter clutch will fully apply in any gear during speeds of 50 mph (80 km/h) or greater and will disengage at speeds below 12 mph (20 km/h) or at full load or kick-down conditions.

The converter clutch is designed with small channels in the lining to allow the fluid to quickly reduce temperatures after the clutch fully engages.

There is a strategy that can be utilized where the load on the engine can be reduced when the vehicle is at a stop in gear with the brake applied. This is accomplished by releasing the "A" clutch which uncouples the input torque from the converter. This minimizes engine load reducing fuel consumption. This uncoupling phase is referred to as "**Stand By Control**" (SBC).

As seen in Figure 2 of the clutch application chart, this gearbox requires only 5 clutch packs with which 6 gears and reverse are obtained. Clutch packs A, B and E are the driving clutches while Clutch packs C and D are holding or brake clutches. Since clutch packs A, B and D are rotational, there is a tendency to have centrifugal force creep the clutch on when it is not in use which could cause premature damage to the pack. As a preventive measure, a balance area is provided in each of these clutch packs in front of the piston. A slight amount of fluid pressure is supplied to this area which is used to balance centrifugal head oil behind the apply piston neutralizing its affect. This feature is referred to as "**dynamic pressure balance**." This feature also

assists in greater engagement and disengagement control of the clutch pack which ultimately improves gear shift comfort.

G M's 6L80 operates in a similar manner regarding both the clutch application and dynamic pressure balance they call the **Compensator Feed Fluid**. One deviation is that the 6L80 uses a low sprag while the 6HP26 does not use any free wheel devices. All shifting scheduling is executed with an overlap strategy. The purpose of eliminating freewheel devices is to save weight and space (money too!). So each shift is controlled by the computer via the solenoids and regulating valves to release one clutch while applying the oncoming clutch overlapping them with various pressures and time to accommodate the amount of torque at the time of the shift.

These clutches drive and hold different parts of the planetary gear sets known as the **Lepelletier Planetary Gear Train**. This set up consists of a single planetary carrier and a double planetary carrier.

**The single planetary (input) carrier** is located behind the front pump (Figure 3). Its sun gear (#1) splines to the pump stator support holding it stationary at all times (Figure 4). The internal ring gear is being driven by the turbine (input) shaft through the E clutch drum as the drum has the internal ring gear on the back side of it (Figure 5).

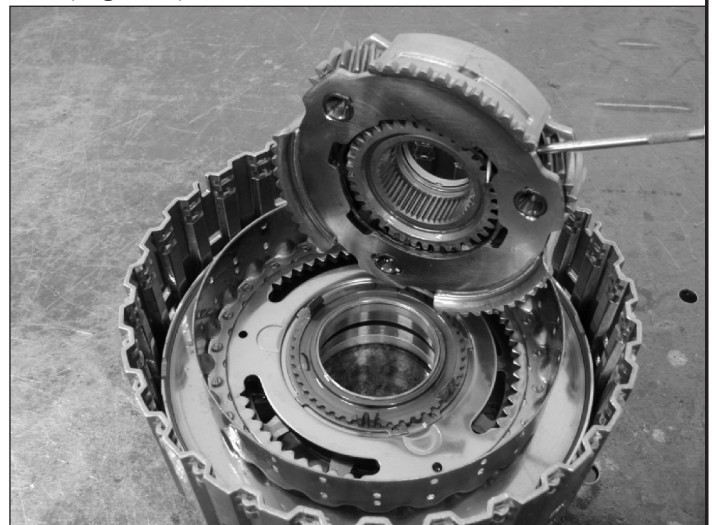

Figure 3

Copyright © 2008 ATSG

THE ZF6HP26 TRANSMISSION



Figure 4



Figure 5

The carrier is then linked to the A clutch drum as seen in figure 3. So the front powerflow begins with the turbine shaft being driven by the converter which drives the internal ring gear that is integral to the turbine shaft. The internal ring gear then drives the pinions around the stationary sun gear causing the carrier to drive the A clutch drum in a reduction. When the A clutch applies, it will then drive a rear sun gear (#3) in the rear planetary in that reductive rotation. When the B clutch applies, it locks onto the A clutch drum which then drives a front (or middle #2 ) sun gear in the rear planetary in the same reductive speed.

*The double planetary (output) carrier* is located in the back of the transmission where its' internal ring gear drives the output shaft (Figure 6). The rear sun gear (#3) in this double planetary assembly is driven by the A clutch and meshes with three short pinions. The front sun gear (#2) which meshes with three long pinions in this double planetary assembly is driven by the B clutch (Figure 7) while the C clutch is used to hold the #2 sun gear stationary.

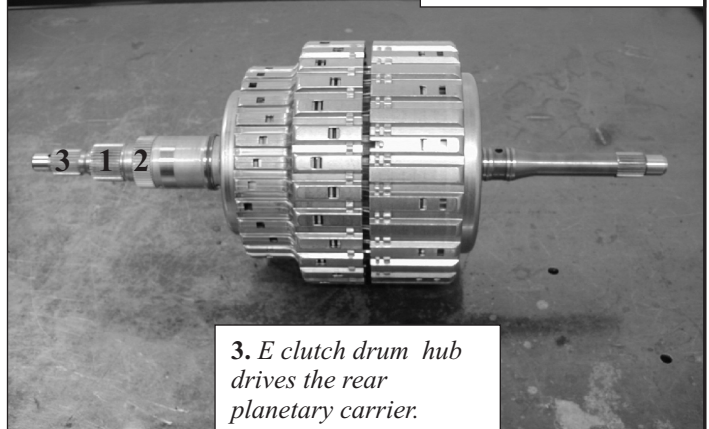

Figure 6

The E clutch drum drives the carrier assembly (Figure 7) while the D clutch is used to hold it stationary.

1. A clutch drum hub drives rear sun gear.

2. B clutch drum hub drives rear (or middle) sun gear.



3. E clutch drum hub drives the rear planetary carrier.

Figure 7

THE ZF6HP26 TRANSMISSION

**Powerflow in first gear:** The A clutch is applied and is driven in a reduction through the front planetary assembly via the turbine shaft. The A clutch in turn inputs torque to the small rear (#3) sun gear. The D clutch is also applied holding the double planetary output carrier stationary. This causes the small rear (#3) sun gear to drive the short pinions, the short pinions drive the long pinions and the long pinions drive the internal ring gear and output shaft in an approximate reduction ratio of 4.171:1 (Figure 8).

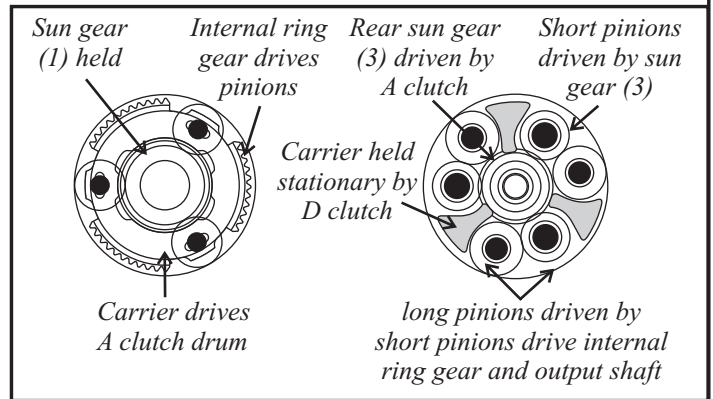

Figure 8

**Powerflow in 2nd gear:** With the A clutch still applied, the turbine shaft is driving the A clutch drum in a reduction. The A clutch drum continues to drive the small rear (#3) sun gear in the double planetary output carrier. The D clutch is released and the C clutch is applied which holds the larger front (#2) sun gear in the double planetary output carrier stationary. The reaction of the short pinions being driven by the A clutch and the long pinions being forced to walk around the stationary sun gear, causes the internal ring gear and output shaft to rotate in an approximate reduction ratio of 2.340:1 (Figure 9).

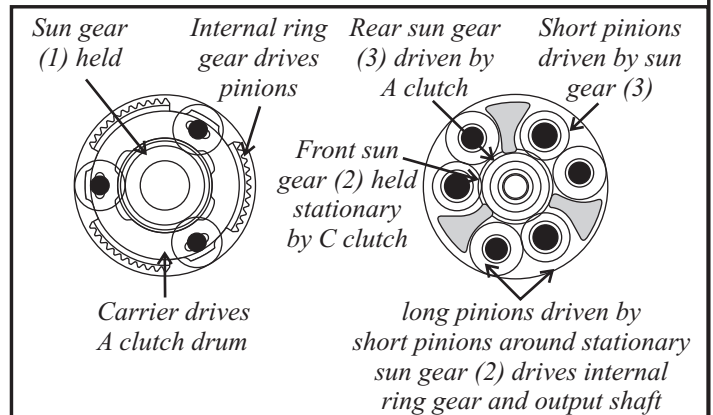

Figure 9

**Powerflow in 3rd gear:** Once again the A clutch is applied as it is in 1st and 2nd. The C clutch is released and the B clutch is applied. This now drives both sun gears in the same direction and at the same speed inside the double planetary output carrier. This causes the pinions, the carrier and internal ring gear to rotate as 1 complete assembly driving the output shaft in an approximate reduction ratio of 1.521:1 (Figure 10).

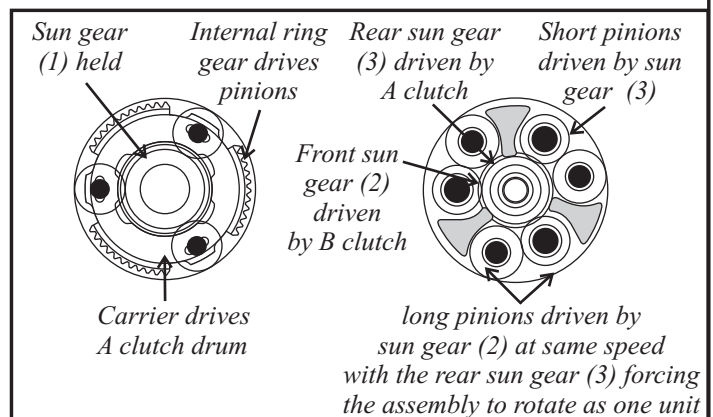

Figure 10

The reason for the overall ratio continuing to be in a reduction rather than a 1:1 ratio is that both the A and B clutch drums are rotating in a reduction when compared to turbine shaft speed. (See explanation on the previous page under the single planetary (input) carrier heading on page 4).



THE ZF6HP26 TRANSMISSION

**Powerflow in 4th gear:** The A clutch still applied drives the small rear (#3) sun gear. The B clutch is released and the E clutch applies driving the double planetary output carrier at turbine shaft speed. The action of the carrier forcing the pinions to rotate around a reductive spinning sun gear causes the internal ring gear and output shaft to rotate in an approximate reduction ratio of 1.143:1 (Figure 11).

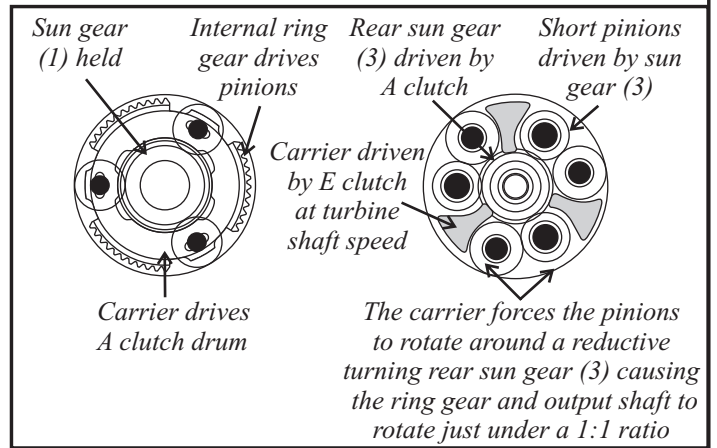

Figure 11

**Powerflow in 5th gear:** The A clutch is released and the B clutch is applied which drives the larger front (#2) sun gear in the double planetary output carrier. The E clutch is still applied driving the double planetary output carrier at turbine shaft speed. The reaction of the long pinions being forced to rotate around a reductive spinning sun gear (#2) causes the internal ring gear and output shaft to rotate in an approximate overdrive ratio of 0.867:1 (Figure 12).

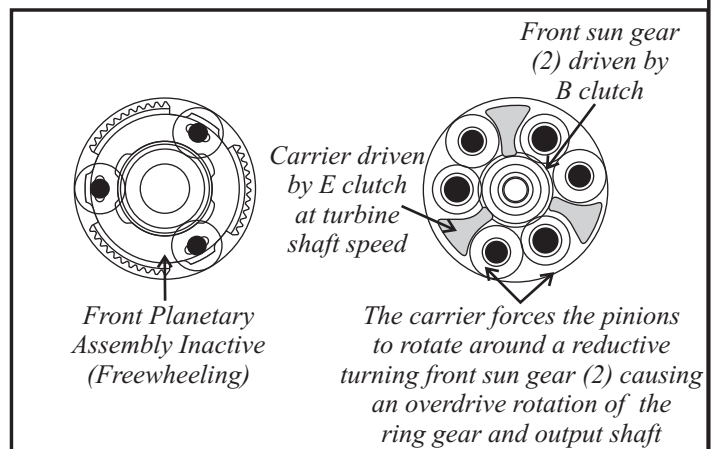

Figure 12

**Powerflow in 6th gear:** The B clutch is released while the E clutch is still applied driving the double planetary output carrier at turbine shaft speed. The C clutch applies which now holds the larger (#2) sun gear in the double planetary output carrier. The reaction of the double planetary output carrier spinning at turbine shaft speed forcing the long pinions to rotate around a stationary larger (#2) sun gear, causes the rear internal ring gear and output shaft to rotate in an approximate overdrive ratio of 0.691:1 (Figure 13).

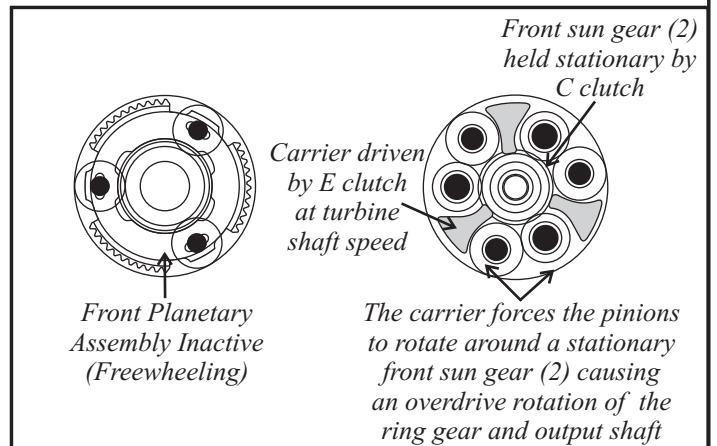

Figure 13

THE ZF6HP26 TRANSMISSION

**Powerflow in reverse:** The B clutch is applied driving the larger front (#2) sun gear in the double planetary output carrier. The D clutch is also applied which holds the double planetary output carrier. This causes the sun gear to drive the long pinions in an opposite rotation of the turbine shaft. The long pinions then drives the internal ring gear and output shaft in a reverse reduction ratio of approximately 3.403:1 (Figure 14).

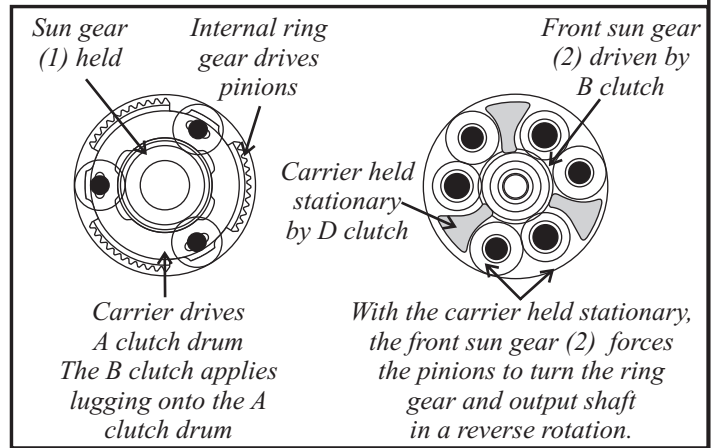

Figure 14

**Shop Notes:**

The pan should not be removed at temperatures above 104°F (40°C) as the pan is plastic and **will distort at high temperatures** (Figure 21).

The drain plug has a double ended arrow embossed into it that should be observed in relationship to the arrow embossed into the pan along side the plug. The double ended arrow embossed into the plug indicates its full range of movement. **If over tightened, you will crack or distort the pan** (Figure 21).

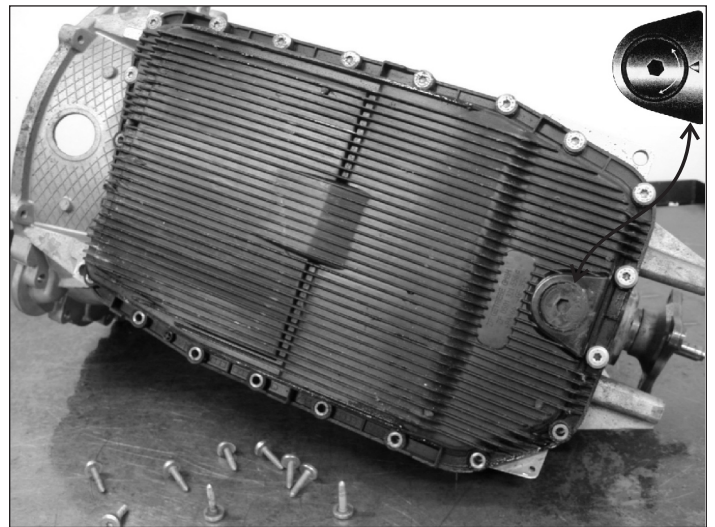

Figure 21

The filter, debris magnet and pan gasket are all integral to the pan and are replaced as one unit. If pan to case attaching bolts are **over tightened, it will crack or distort the pan** (Figure 22).



Figure 22

## THE ZF6HP26 TRANSMISSION

Whether you are working on an E-version or the M-version of the 6HP26, both contain the combination valve body and electronic control module called the **Mechatronic Module** located in the oil sump. The electronic module is completely sealed and oil tight designed to withstand temperatures up to 284°F (140° C). It manages the complete electronic control of the transmission and is considered to be an integral part of the valve body making it not replaceable separately.

The electronic control module contains a Micro-Position Switch which monitors the position of the Park Cylinder with E-versions and the Manual Valve with M-versions. It also contains the Turbine and Output Speed Sensors, the Temperature Sensor and the Transmission Control Module (Figure 16).

The valve body contains all the valves, springs, dampers and solenoids. The E-versions have 3 MV solenoids and 6 EDS or pressure control solenoids. The M-versions have the same 6 EDS solenoids but only 1 MV solenoid (Figure 17).

**The MV 1 and 2 solenoids** are identified by a **black** cap and contains an inlet, outlet and exhaust port. When the solenoid is energized, the inlet is open to the outlet port and the exhaust is blocked. When the solenoid turns off, the inlet is blocked and the outlet is opened to exhaust (Figure 21).

**The MV3 solenoid** is identified by a green cap and is part of the park lock cylinder.

**The EDS or pressure control solenoids** convert electrical current into a proportional hydraulic pressure. They are designed in two different ways:

**EDS solenoids 1, 3 and 6** are identified by a **yellow** cap and are designed using a rising curve. In other words, at 0 mA it produces an output pressure of 0 psi (0 bars). At 700 mA output pressure rises as high as 67 psi (4.6 bar)s.

*At 68°F (20°C) they measure approximately 5 ohms. They are supplied with system voltage and are ground side controlled.*

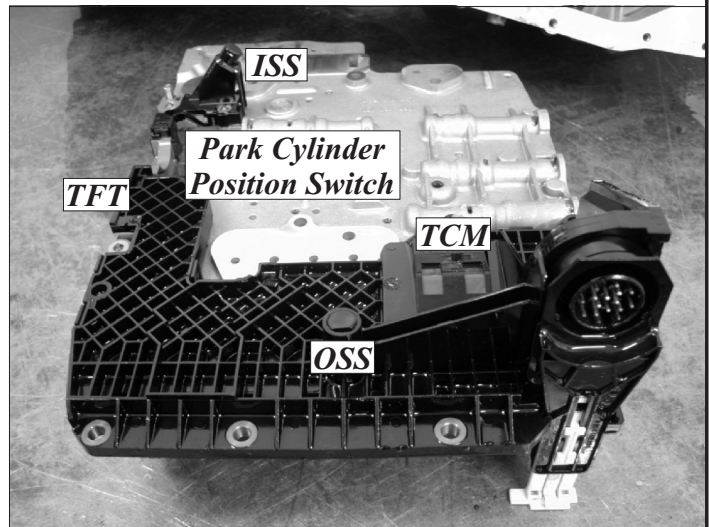

Figure 16

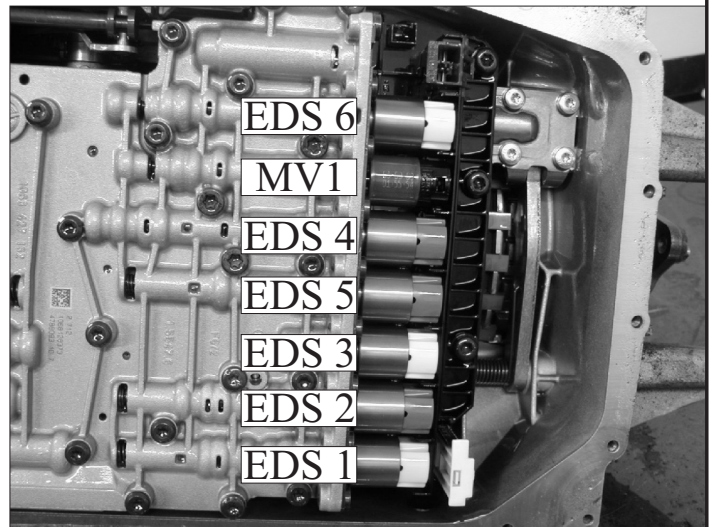

Figure 17

**EDS solenoids 2, 4 and 5** are identified by a **blue** cap and are designed using a falling curve. In other words, at 0 mA it produces an output pressure of 67 psi (4.6 bars). At 700 mA output pressure rises as low as 0 psi (0 bars).

*At 68°F (20°C) they measure approximately 5 ohms. They are supplied with system voltage and are ground side controlled.*

**THE ZF6HP26 TRANSMISSION**

**CASE CONNECTOR TERMINAL FUNCTION**

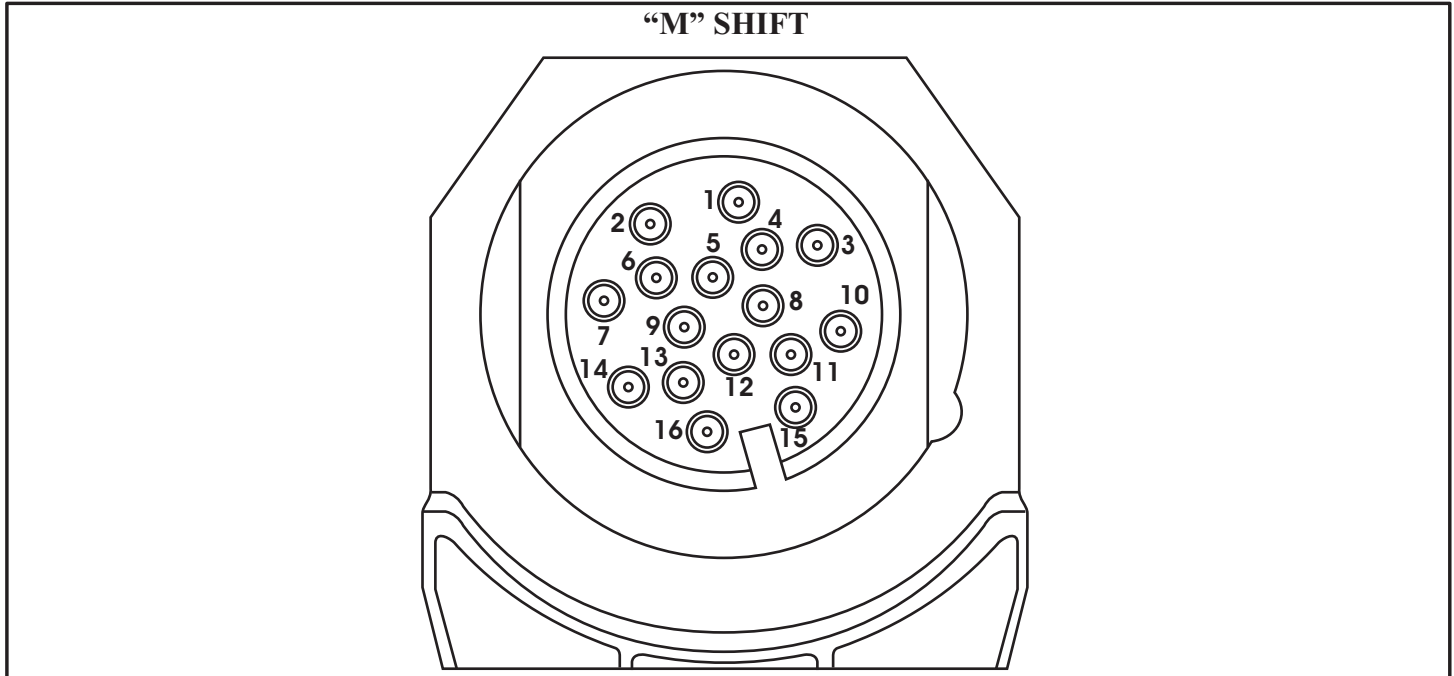

PIN #	FUNCTION	NOTES
1	“M” GATE POSITION	MANUAL SHIFT PROGRAM
2	CAN L	CAN LOW
3	ISO K	K LINE
4	TOUCH -	MANUAL DOWNSHIFT SIGNAL
5	TOUCH +	MANUAL UPSHIFT SIGNAL
6	CAN H	CAN HIGH
7	SHIFTLOCK	CONTROL SIGNAL FOR SHIFTLOCK & INTERLOCK
8	NOT IN USE	
9	TCM TERMINAL 15	WAKE-UP SIGNAL
10	“P” SIGNAL	P LINE FOR STARTER INHIBIT
11	SHIFTLOCK	APPLY BRAKE BEFORE SELECTING POSITION
12	NOT IN USE	
13	TCM TERMINAL31-1	GROUND
14	TCM TERMINAL 30	PERMANENT POSITIVE (EGS SUPPLY VOLTAGE)
15	INTERLOCK	
16	TCM TERMINAL31-2	GROUND

Copyright © 2008 ATSG

Figure 18  
Automatic Transmission Service Group

**THE ZF6HP26 TRANSMISSION**

**CASE CONNECTOR TERMINAL FUNCTION**

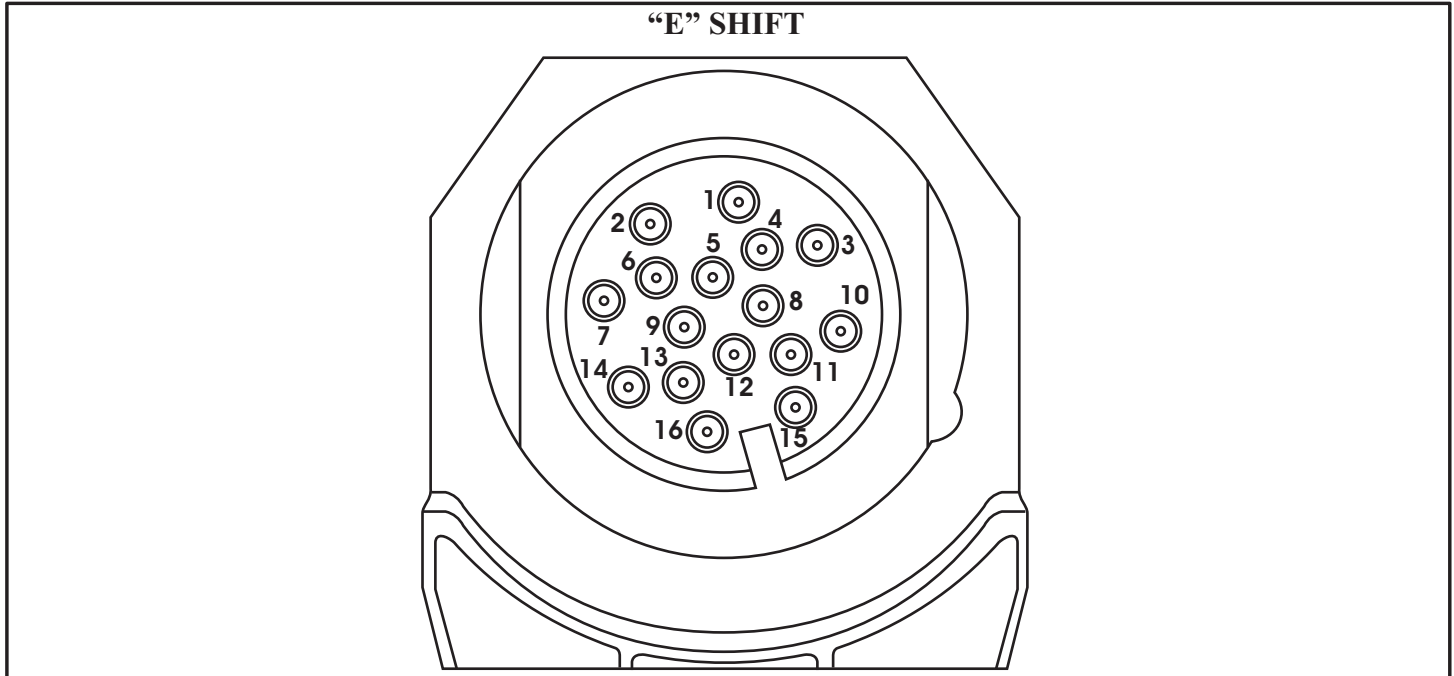

PIN #	FUNCTION	NOTES
1	SERIES LINE	AVAILABILITY LINE FROM STEERING COLUMN SWITCH CENTER
2	CAN L	CAN LOW
3	ISO K	K LINE
4	NOT IN USE	
5	NOT IN USE	
6	CAN H	CAN HIGH
7	NOT IN USE	
8	NOT IN USE	
9	TCM TERMINAL 15	WAKE-UP SIGNAL
10	“P” SIGNAL	P LINE FOR STARTER INHIBIT
11	NOT IN USE	
12	NOT IN USE	
13	TCM TERMINAL31-1	GROUND
14	TCM TERMINAL 30	PERMANENT POSITIVE (EGS SUPPLY VOLTAGE)
15	NOT IN USE	
16	TCM TERMINAL31-2	GROUND

Copyright © 2008 ATSG

Figure 19  
Automatic Transmission Service Group

THE ZF6HP26 TRANSMISSION

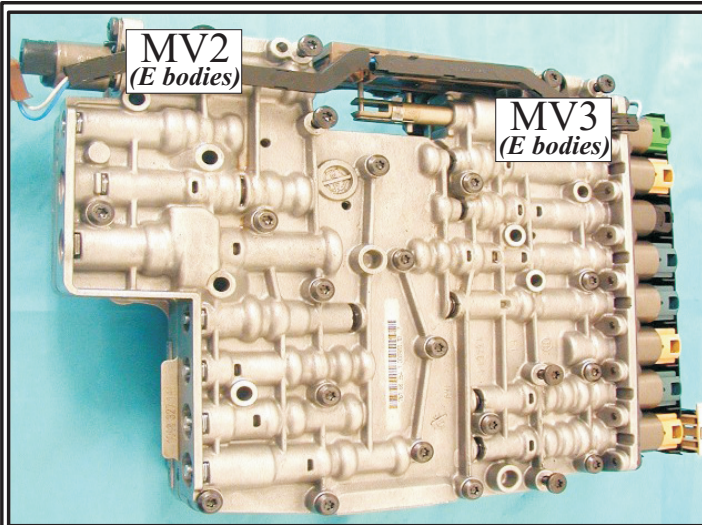
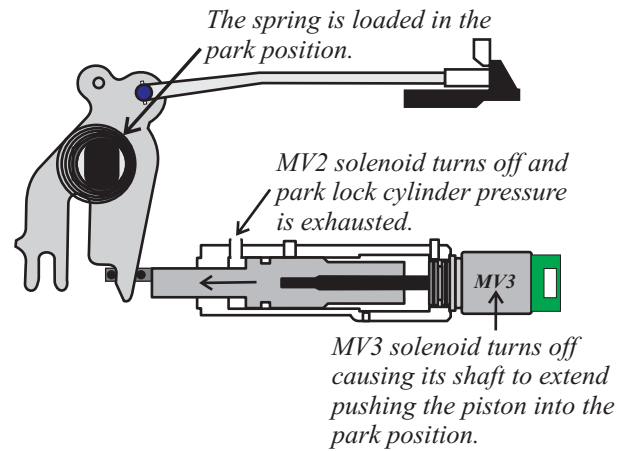

Figure 20

Park Position



Out of Park Position

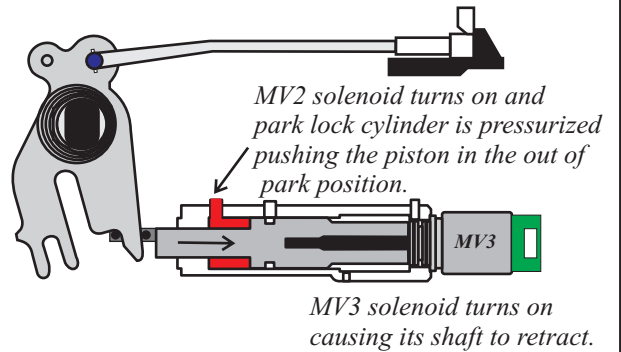

Figure 23

Off

On

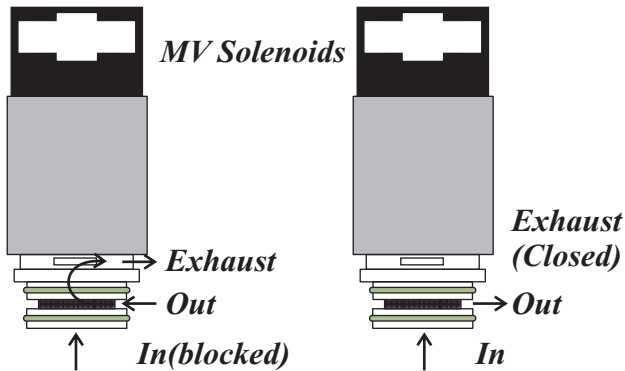

Figure 21

Off

On

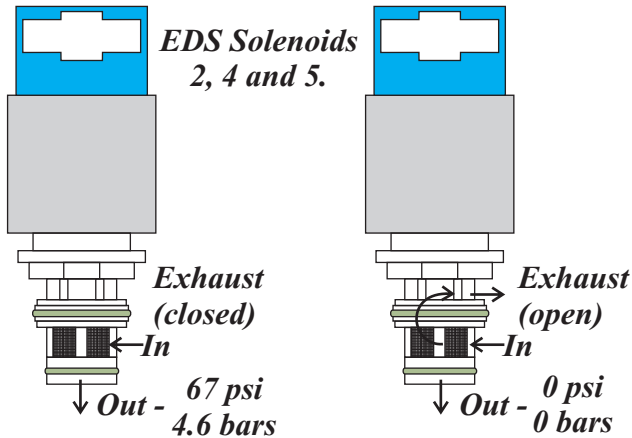

Figure 22

Off

On

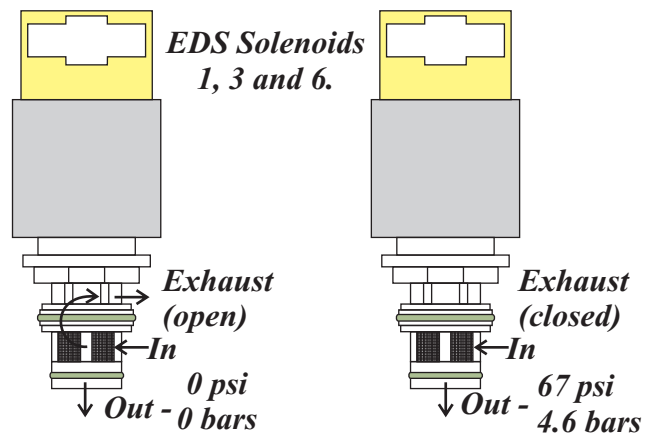

Figure 25

## THE ZF6HP26 TRANSMISSION

### “E” SHIFT BMW STUCK IN PARK

With E-versions of the 6HP26, there are no mechanical connections from a shift lever to the transmission. The *shift into park is mechatronic controlled* via the MV2 and MV3 solenoids. The Parking Lock can hold the vehicle on uphill and downhill grades of up to 32% and will not engage at any speeds above 1.2 mph (2 km/h).

Part of the *Park Lock* system consists of a typical parking rod with a tapered tip that sits into a guide which when park is commanded, will extend into a spring loaded parking pawl. The tapered tip will force the parking pawl to pivot into the parking gear. Once the pawl engages the gear teeth of the parking gear, the output shaft is locked.

There is a pre-loaded barrel spring mounted on a rotating lever that operates the parking rod with the tension of the spring pushing the lever and rod in the park position. To release park, the MV3 and MV2 solenoids are energized.

The MV3 solenoid is mounted on the back side of a parking lock cylinder. Inside the cylinder there is a piston which the front of it connects to the rotating lever. When the MV3 solenoid is off, a shaft extends out from the solenoid pushing the rear of the piston and lever into the park position. When a command is made to release park, the MV3 solenoid is energized and the shaft retracts. At which time the MV2 solenoid is also energized and it supplies fluid pressure to a chamber inside the front area of the cylinder which pushes the piston, rotating lever and parking rod into a released position (Figure 26).

When Park is requested, the MV2 solenoid is turned off and the pressure keeping the piston in a released position is exhausted. The MV3 is also turned off and the shaft extends pushing the piston assisting the barrel spring on the rotating lever to move the park rod into the Park position (Figure 26).

The transmission can only be shifted out of Park through the Mechatronic system with the engine running, brake depressed and either R, N or D is selected. If there should be any reason the engine can not run, a Bowden cable (bi-directional cable) can be used for a manual release of the parking pawl and is usually found behind a kick panel.

Detent balls are used to assist the piston in remaining in the “out-of-park” position (*referred to as the “N” position*) when the engine is off.

Position “N” is automatically selected should the engine be turned off with the key remaining in the ignition. It will remain this way for 30 minutes before it will automatically engage Park. However, it could remain in the “N” position for another 30 minutes if “N” is selected again before the previous 30 minutes have elapsed.

There are some manufacturers that include an *Electromechanical Parking Brake* which interacts with the Park Lock system. Depending on the operating status of the electromechanical parking brake, it is possible to engage park when the engine is not running in the event of a fault with the electromechanical parking brake.

There is a feature with the electromechanical parking brake called the *Auto Hold* function. Should the system see that the engine is running, position D or R is engaged, the door is open and a seat sensor indicates that the seat is empty, it will automatically engage the Park Lock and set the electromechanical parking brake.

## THE ZF6HP26 TRANSMISSION

### “E” SHIFT BMW STUCK IN PARK....continued

Another aspect of this electromechanical parking brake is if it can not switch from the “hold” to “lock” mode, the Park Lock is automatically engaged following a plausibility check in the EGS control unit. The plausibility check determines whether position N is engaged, the speed is zero and the engine and ignition are off.

As mentioned previously, a Bowen cable is used as a mechanical emergency release of the parking lock system should it not be able to release automatically. This could be caused by several reasons such as a battery failure, the engine can not start, a problem with the engine’s electrical system or the transmission’s electrical system to name a few.

*It is imperative* that this emergency release be used when towing. Depending on the type of fault present, the “N” hold function can not be guaranteed during the entire time of the tow even if output speed is recognized (Please refer to owners manual for the vehicle being towed).

In some applications, this Bowden cable is only accessible by unlocking a cover with the vehicle key.

Whenever the emergency cable is used to release Park, a message of some form will be displayed in the instrument cluster indicating so.

For M-versions of the 6HP26, there is a mechanical connection from a shift lever to a manual valve with which P, R, N and D can be selected. As a result, MV2 and MV3 solenoids are eliminated.



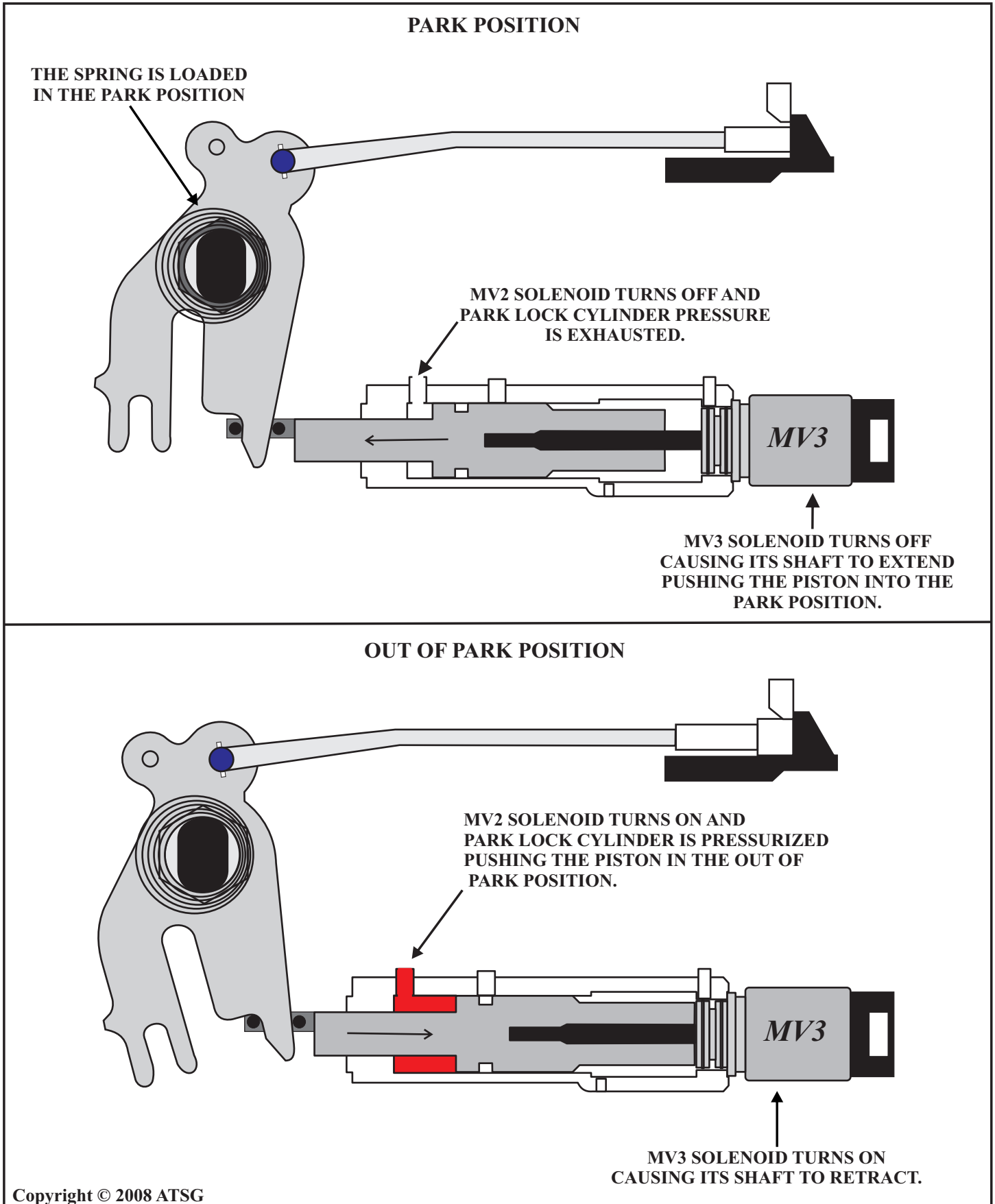
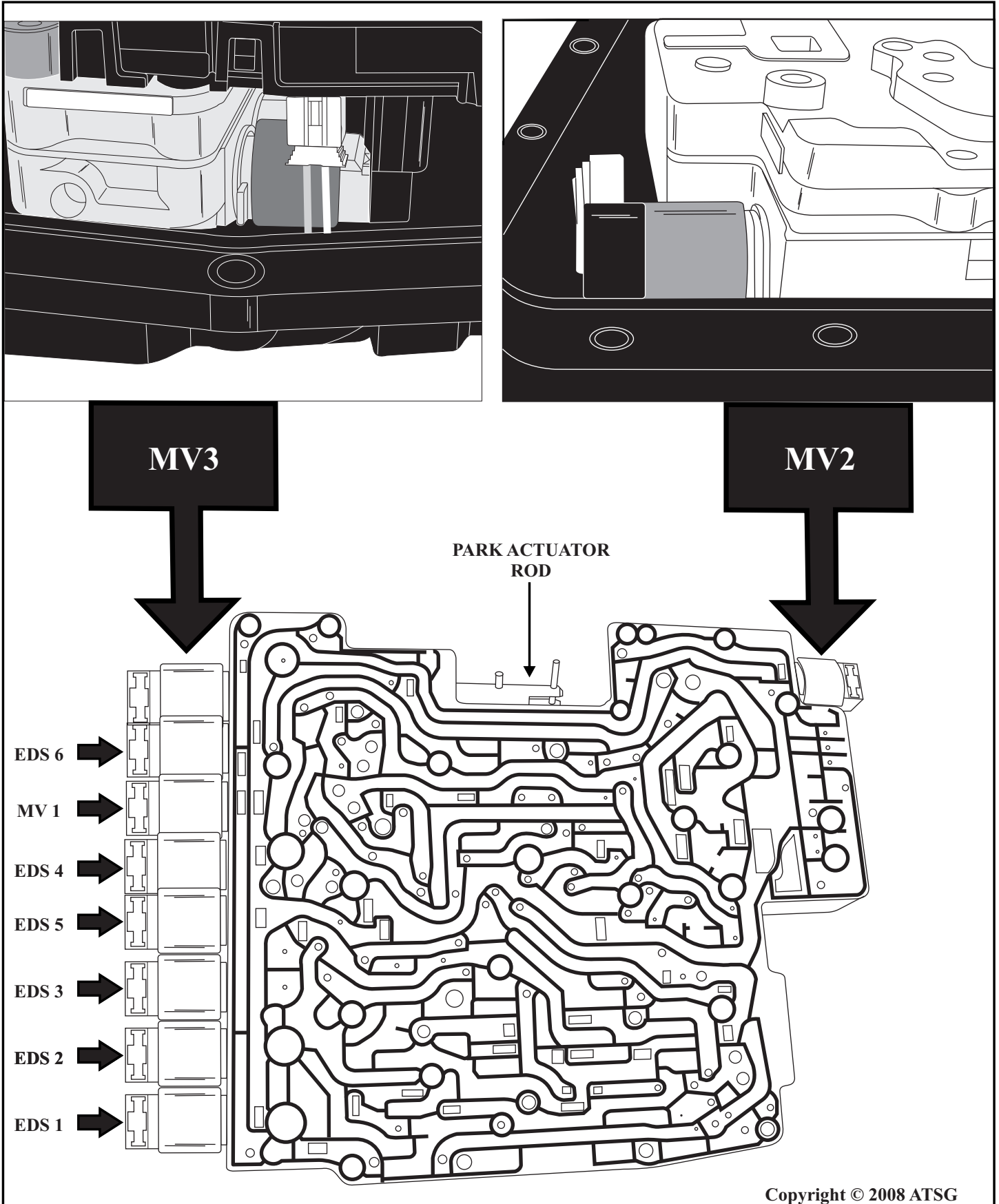

Figure 26



Copyright © 2008 ATSG

Figure 27  
Automatic Transmission Service Group

## THE ZF6HP26 TRANSMISSION

### Electronic Transmission Control

As previously stated, there is no mechanical connection from the gear shift lever to the transmission with E-version units. The positions selected by the shift lever are sent over the CAN bus network to the Mechatronic Module and is known as shift by wire.

### Shift by Wire Styles

One example of a shift lever used for shift by wire has some features that *resembles a typical shift lever* (Figure 28). What will catch your attention quickly is that from top to bottom the lever will begin with the reverse position symbolized by an upper case R.

P for Park is located at the mid-position while D for Drive follows underneath.

Along side the R is a corresponding Up arrow, along side the P is an Up and Down arrow while along side the D is a Down arrow.

**Position R:** To select reverse the brake needs to be depressed and the selector lever be pushed to its fullest travel in the up or counter clockwise direction.

**Position N:** If a neutral position is desired while in Reverse, a simple downward tap of the shift lever is all that is needed. Likewise from the Drive position, a simple upward tap is all that is required. From the Park position, a tap of the lever in either direction will place the vehicle in Neutral. Neutral will automatically be selected when the ignition is turned off but the key remains in the cylinder. Park will automatically be selected after 30 minutes unless N is selected before the 30 minutes have elapsed at which time an additional 30 minutes is added to the time in Neutral.

**Position D:** Depress the brake and pull the selector lever to its fullest travel in the downward or clockwise direction.

**Position P:** Park engages by a push of a button built into the shift lever. Park automatically disengage when R, N or D is selected when the engine is running. Park will automatically engage when the ignition key is removed from the cylinder.

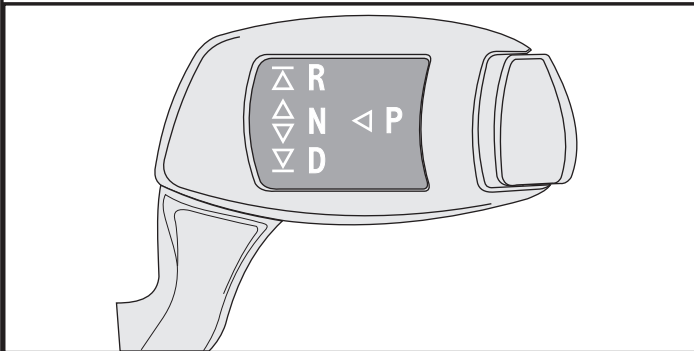

Figure 28

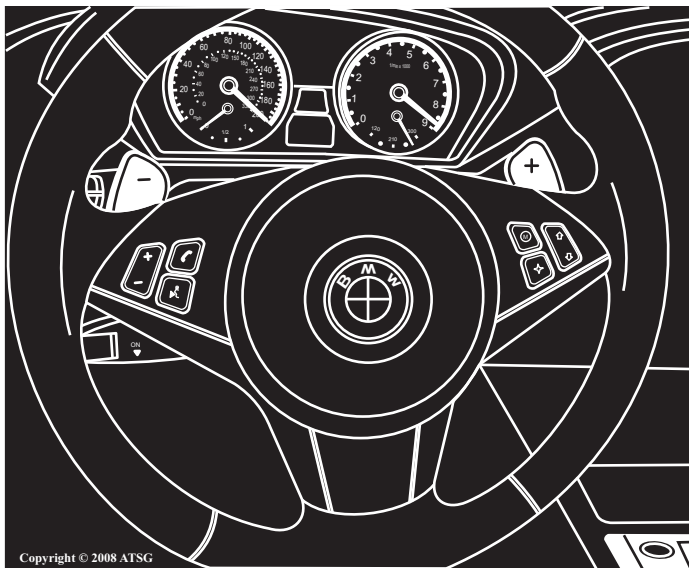

Figure 29

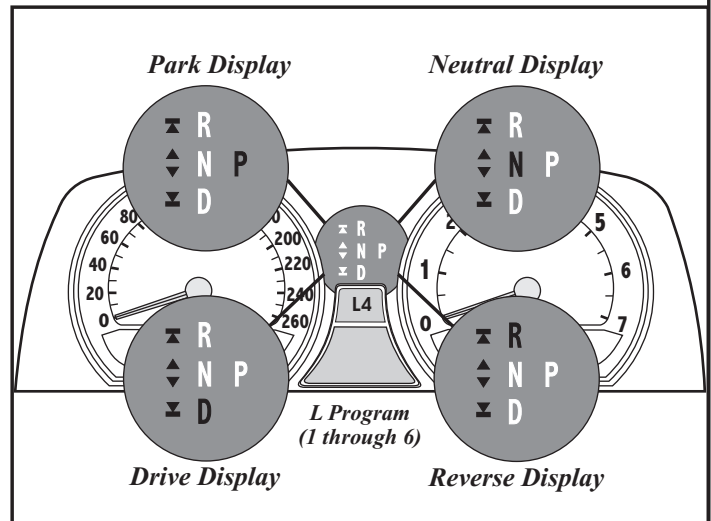
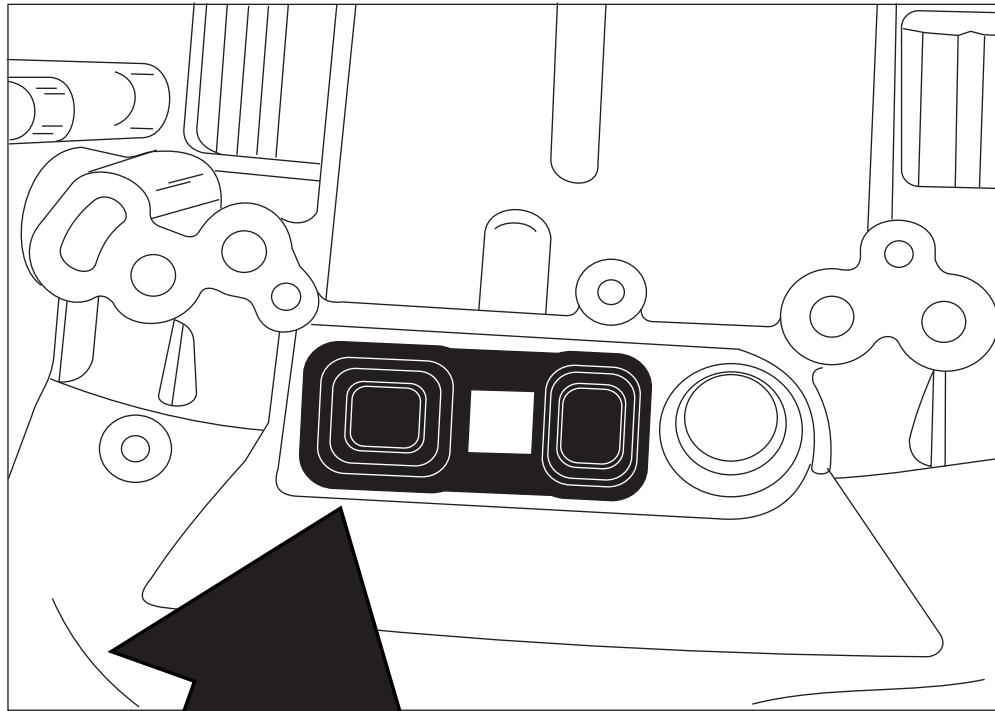

Figure 30

BRIDGE SEAL



**ENOUGH LINE PRESSURE IS LOST  
FROM THE DAMAGED BRIDGE SEAL  
TO CAUSE THE TCM TO PUT THE  
TRANSMISSION BACK INTO PARK**

DAMAGED BRIDGE SEAL

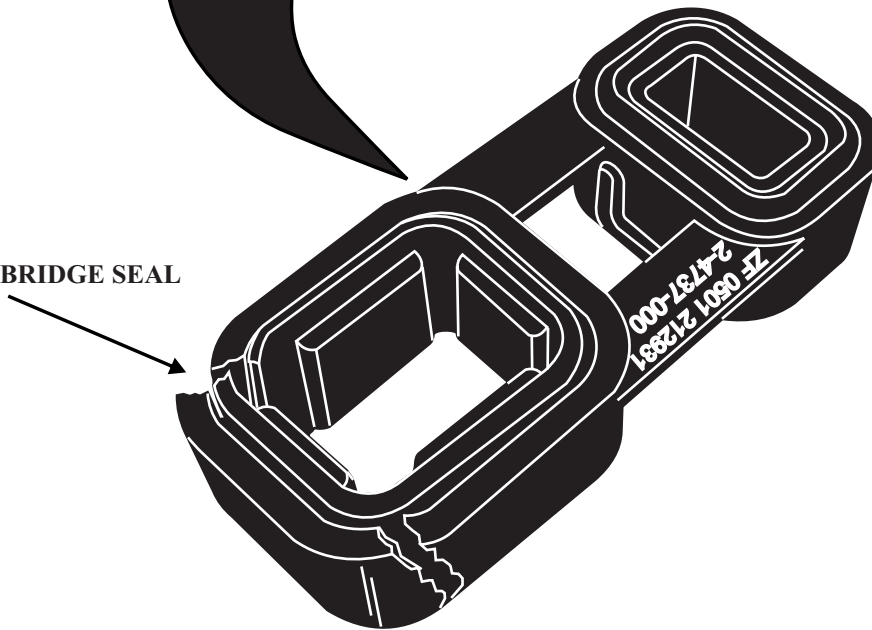

**ZF PART NUMBER  
0501215718**

Copyright © 2008 ATSG

Figure 31

## THE ZF6HP26 TRANSMISSION

Another feature that could be encountered is referred to the **L Push Button in MFL** (Figure 32). This is a multi-function push button switch with a limiting function strategy. When D is selected, the transmission will automatically shift through all 6 speeds utilizing a variety of shift profiles programmed into the computer to accommodate the operator's driving habits.

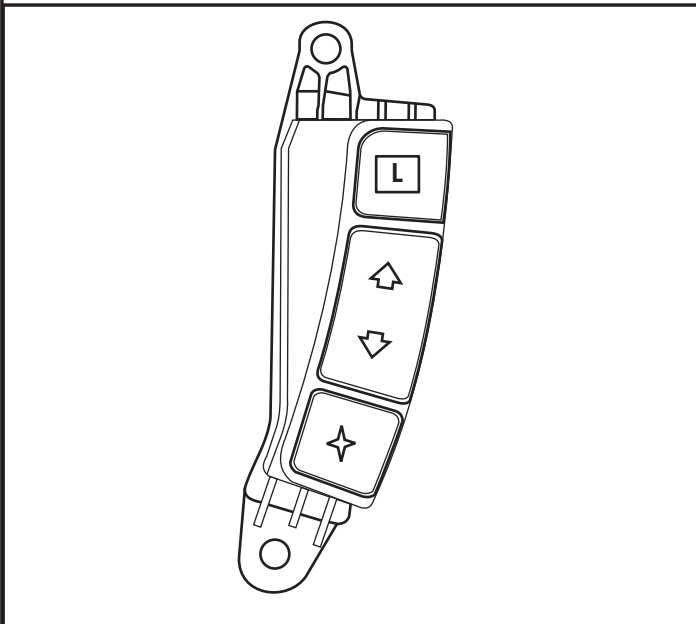

Figure 32

Whenever the limitation mode is selected by pressing the L button, the current gear at that time is retained and an indicator light is illuminated identifying the selected gear (Figure 32). If the vehicle was in 4th gear at the time L was selected, the highest gear will be 4th. Gears 1 through 4 will then be shifted automatically.

The transmission will downshift 1 gear at a time each time the L button is pressed. That gear will then be maintained as the most upper gear it will shift up to automatically. And as previously stated the highest gear selected in the limitation mode will be illuminated in the instrument cluster (L1 through L6) as illustrated in figure 32.

In the limitation mode there are no manual up shift controls nor is there a forced up-shift at maximum engine rpm. The computer will also not allow certain downshift requests that would cause damage to the transmission and/or engine.

*(Most Jaguar models utilize the Mechanical Mechatronics in conjunction with a J Gate shifter).*

### **Indication Details:**

In addition to the limitation mode lights being illuminated in the instrument cluster, Park, Reverse, Neutral and Drive selections are also displayed.

Similar to the previous style shift lever option, R, N and D positions are associated with up and down arrows. When reverse is selected the R will illuminate as is with P for Park, N for Neutral and D for Drive. The L1 through L6 will illuminate below the D light in a separate window.

When the vehicle is running in Park for a period of time, all gear position indicator lights will go off.

This will occur when the CAN bus enters the sleep mode. If the CAN bus is wakened by a signal other than a gear selection, the lights may remain in the off state.

As previously mentioned, the vehicle will hold a neutral position for 30 minutes when the engine is off and the key remains in the cylinder, after which it will automatically go to the Park position. The N light will begin to flash at a 1.5 Hz frequency prior to 30 minute expiration time.

## THE ZF6HP26 TRANSMISSION

## BMW CONSOLE SHIFTER

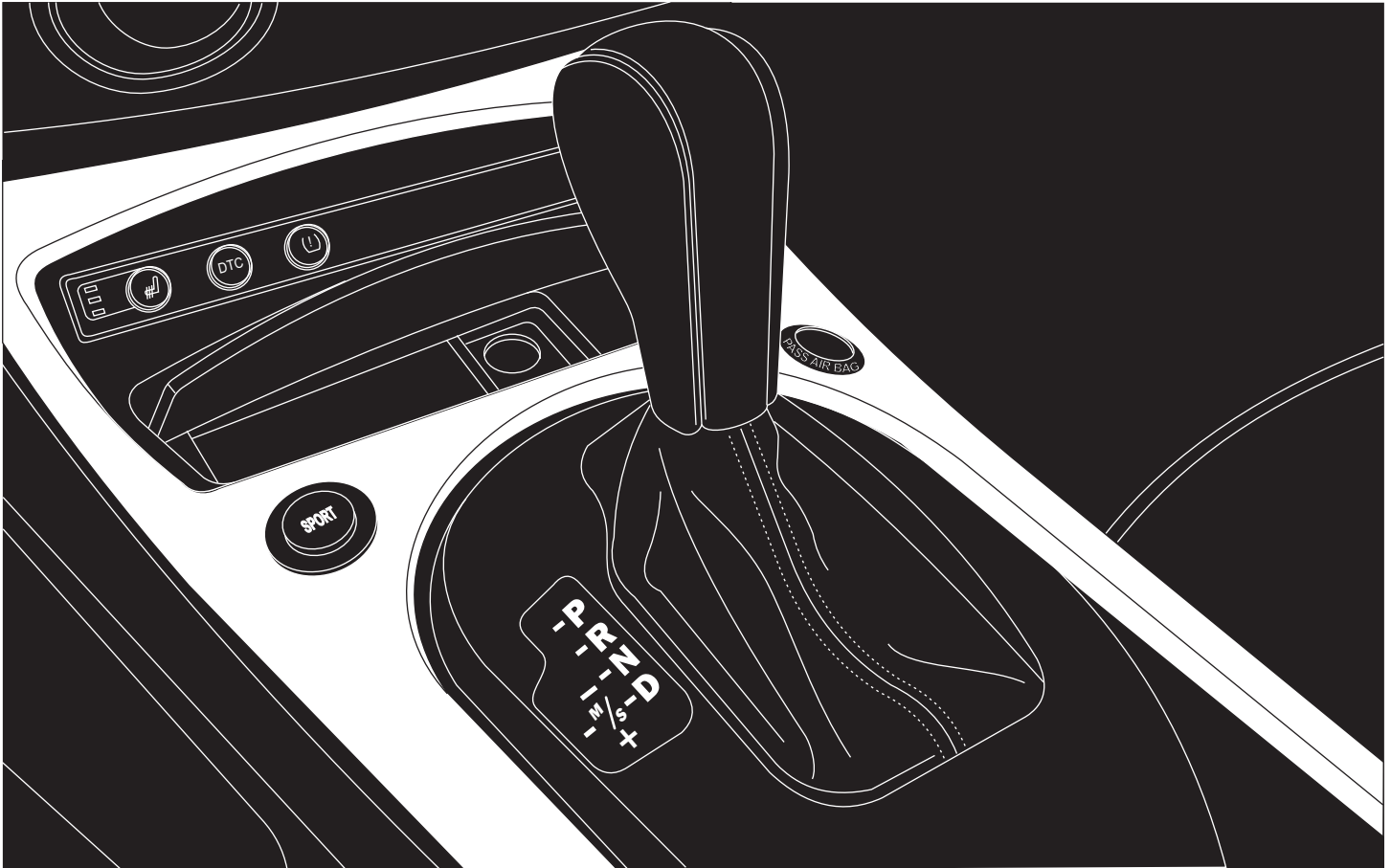

Figure 33

- P - Park**, should only be selected when the vehicle is at a standstill. First apply the park brake and then select park, this will take the entire weight of the vehicle off the park mechanism, such as when the vehicle is parked on an incline.
- R - Reverse**, should only be selected when the vehicle is at a standstill with the engine at idle.
- N - Neutral**, may be selected when the vehicle is at a standstill, but first apply the park brake to prevent vehicle roll away. May also be selected while the vehicle is moving.
- D - Drive**, is the standard position for normal driving in the XE program (AGS) and provides automatic up and downshifts from 1st to 6th gears and 6th to 1st. The adaptive transmission control (AGS) system contains various driving programs such as Towing, Hillclimb and Descent, Constant Highway Speeds, City Driving and cornering. These programs are electronically selected which automatically modifies transmission shift characteristics according to rolling resistance, engine load, accelerator pedal movement and vehicle speed.

## THE ZF6HP26 TRANSMISSION

### BMW CONSOLE SHIFTER

#### ***“S” Program***

The “S” Program is a performance oriented program, where the gear changing characteristics of the transmission are moved up to higher engine speeds. To select the “S” Program, push the button located on the console that says “SPORT” as seen in Figure ???. Gears 1-6 and 6-1 are selected automatically.

#### ***“M” Program***

The “M” program is a manual shift program which is activated by simply pushing the selector lever to the left and then to the plus sign for upshifting or the minus sign for downshifting. It is possible to drive off in first, second or third gears, however fourth gear can be manually selected from a speed of 6 mph (10 km/h). Fifth gear can be selected manually from a speed of 22 mph (35 km/h) and sixth gear can be selected manually from a speed of 28 mph (45 km/h).

#### ***Failsafe Operation***

When a fault occurs all solenoids turn off. The hydraulic system is designed so that restricted operation is still possible. This means that if the transmission is in 1st, 2nd or 3rd at the time of the fault, when all solenoids turn off, the hydraulic design is to force a 3rd gear hold. Likewise, if the transmission is in 4th, 5th or 6th when the fault occurs, when all solenoids turn off, the hydraulic design is to force a 5th gear hold.

The vehicle will then move forward under these restrictions. Once the engine is turned off and restarted, it will not be possible to select D. The vehicle will remain in the Park position.

If the fault should occur while in the reverse range, neutral will be selected and when the vehicle drops below 3 mph (5 km/h), Park will engage.

Under these conditions the only way park can be released is with the emergency mechanical release cable.

Shift lever operation can not be detected or implemented if total transmission control failure should occur or failure with the Steering Column Switch Center (SZL) has occurred. In addition to flashing warning lights, a notable acoustic warning “gong” type sound will occur notifying the driver that a problem exists. A decrease in acceleration will then follow these warning signals.

The EGS has the capability to output various text messages in a “Check Control Message” display in the instrument cluster.

Should there be ***CAN bus failure*** the transmission will shift to 3rd or 5th depending upon vehicle speed and the previous gear engaged at the time of fault. After a restart, 3rd gear is engaged in the D position. All gear select ranges will occur from the hard wire input. The shift lock function is deactivated making it possible to select a gear without depressing the brake. The N hold feature turns off and Park will engage below 1.2 MPH (2 km/h) automatically.

THE ZF6HP26 TRANSMISSION

JAGUAR J-GATE SHIFTER

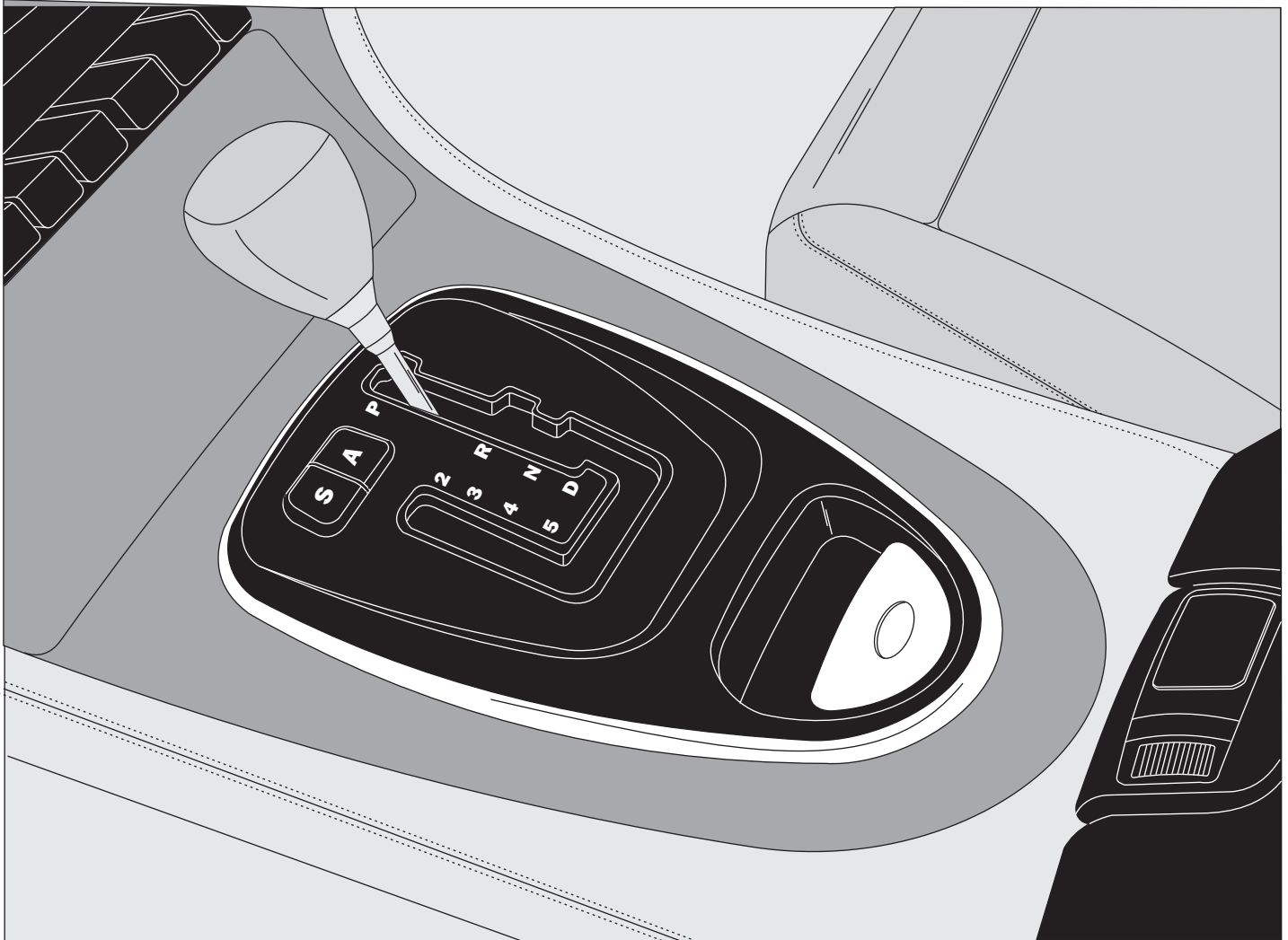

Figure 34

- P - Park**, should only be selected when the vehicle is at a standstill. First apply the park brake and then select park, this will take the entire weight of the vehicle off the park mechanism, such as when the vehicle is parked on an incline. The park switch signal is used for an audible warning when the gear shift lever is left out of the park position and the ignition is turned off.
- R - Reverse**, should only be selected when the vehicle is at a standstill with the engine at idle.
- N - Neutral**, may be selected when the vehicle is at a standstill, but first apply the park brake to prevent vehicle roll away. May also be selected while the vehicle is moving.
- D - Drive**, is the standard position for normal driving and is the “Normal Mode” program which provides automatic up and downshifts from 1st to 6th gears and 6th to 1st.

**Shift Map Selection**

The 6HP26 Transmission Control System utilizes a number of driver selectable modes as well as automatically selectable modes. The TCM will automatically select a mode depending on current driving conditions. These driving modes are explained on the following page.



## THE ZF6HP26 TRANSMISSION

### JAGUAR J-GATE SHIFTER

#### ***Manual Mode***

When the driver moves the shift lever to the left in the J-Gate, second, third, fourth or fifth gears can be selected. When the shifter is moved from the “D” position to position 5 in manual mode, selector position is transmitted to the TCM via CAN by hall effect switches in the J-Gate assembly.

#### ***Sport Mode***

“Sport Mode” is a driver selected program which can be activated by pressing the “S” button on the console. Sport mode raises the transmission shift points as well as operating pressure.

#### ***Cruise Mode***

When the driver engages cruise control the TCM will select a new shift map to reduce shift busyness during cruise mode.

#### ***Hot Mode***

“Hot Mode” is an adaptive mode the transmission will enter when atf, engine coolant, engine oil temperature or substrate (TCM) temperature becomes too high. This mode will automatically select new shift and TCC apply maps in an attempt to reduce the temperature.

The shift map for “Hot Mode” will enable the transmission to shift to higher gears at lower speeds and apply TCC at lower vehicle speeds in lower gears.

#### ***Traction Control Mode***

“Traction Control Mode” is an adaptive program which automatically engages when wheel slippage is detected. The TCM will react by allowing the transmission to upshift thereby lowering the torque applied to the wheels in an effort to reduce wheel spin and will also engage the ABS system.

#### ***Hill & Trailer Towing Mode***

“Hill & Trailer Mode” is an adaptive program, when the TCM detects reduced acceleration for a certain percentage of throttle opening, hill and trailer mode is automatically engaged by the TCM. When this program is engaged, a new shift and TCC apply map will be selected by the TCM. This is designed to reduce shift hunting when climbing a steep incline under load. The transmission will stay in a particular gear longer under these conditions.

## THE ZF6HP26 TRANSMISSION

### ***Fault Indications:***

1. If for any reason CAN bus signals become invalid, the shift pattern and P position indicator lights will remain illuminated regardless of gear selection.
2. When the ignition switch is cycled to the ON position and position P is not detected, position N will begin to flash in addition to the illumination of the “emergency release may be operated” message.
3. While in the D range, should the transmission develop a mechanical problem, the R and N indicator lights illuminate while all the arrows and the D indicator light flash at a frequency of 1.5 Hz. When P is selected under the same conditions, the P, R, N and D positions remain lite while the arrows continue to flash.
4. If the transmission is develops a problem and the CAN bus communication is not functional, the instrument cluster assumes control flashing the arrows at a 1.5Hz frequency while illuminating the R, N and D positions. P will be off.

### ***Interlock***

The “ignition key inserted or not inserted” are monitored by the CAS module which signals ths status to the transmission control module (EGS). When it sends the “ignition key not inserted” signal to the EGS the Park Lock is engaged. The Park Lock can only be released when the ignition key is inserted and the engine is running.

### ***Starter Interlock***

This same CAS module is used to allow start up by monitoring signals from the EGS; the gear selection over the CAN bus and the P signal over a hard wire input directly from the P position sensor. When a P or N selection has been verified, start up is then permitted. The hard wire P input allows for start up in P should the CAN bus be down.

***If the emergency release is operated, the vehicle will not start.***

### ***Warm-up Program***

When engine temperature is below 60°C, a warm-up strategy is immediately selected causing up-shifts to occur at a higher engine RPM. This strategy allows for the engine and the catalytic converter to reach operating temperature quicker. The strategy is aborted after 120 seconds or the engine temperature has risen above 140°F (60°C), which ever occurs first.

### ***Reverse Interlock***

If 5 km/h or higher speeds are observed when reverse is selected, the computer will place the transmission neutral illuminating the N indicator lamp. When speed drops below 3 mph (5 km/h) will a reverse engagement be allowed.

### ***Adaptive Transmission Control***

When in the D range, the computer automatically shifts the transmission through all 6 speeds and converter clutch apply adjusting both the shift points and shift feel providing the driver with most comfortable gear shift characteristics possible. It can on the fly, depending upon the speed in which the accelerator pedal is depressed, switch from an extreme economy shift profile to a performance-oriented shift profile.

### ***Curve recognition***

Curve recognition is another type of shift control strategy preventing up-shifts or downshift while in turns. The DSC module detects variations in front and rear wheel speeds as well as yaw rate signals, steering wheel angle signals and vehicle speed to further determine cornering forces. Once signals indicate straight ahead driving, up-shifts and downshift strategies resume.

## THE ZF6HP26 TRANSMISSION

### *Tire Size*

It is important to note that *tire size* plays an important role in proper curve recognition strategy. For example, ATSG had experienced a call where a persons BMW had 4 very worn tires. One of the tires went flat and was temporarily replaced with the spare. The spare had a much taller tread profile in comparison to the other three tires. As a result, the computer saw a variation in wheel speed and interpreted it as being in a slight turn. The faster the accelerator was depressed, the less it would up-shift. At lighter throttle openings a loss of higher gears was noticed. Kick-down shifts were also prohibited. A capable scan tool provided curve recognition data parameters and it was observed that while driving straight the parameter read “activated” causing the various forward driving shift complaints.

*Brake evaluation* is another shift strategy where the computer monitors wheel speed and the degree in which the brake pedal is depressed. From these inputs as well as what gear the transmission was in when braking began will the computer determine the optimum downshift profile.

There is a *constant driving evaluation* program that observes freeway driving taking note that a constant accelerator pedal position and vehicle speed is maintained. As a result, kick-down shifts become more responsive. Should the driver decide to enter a passing situation, when requested, a downshift will occur immediately.

The *winter program* is activated when wheel slip is observed causing the transmission to have 2nd gear starts and lower shift points. All downshift request that would cause the wheels to spin will also be suppressed.

The *hill recognition function* provides raised shift points when it detects slow vehicle speed and high engine load during a climb. High altitude adaptations also take place to compensate for performance reduction.

*The cruise control shift strategy* obviously maintains the speed requested by the driver. The strategy is such to prevent shift business as well as converter clutch cycling without compromising on the required shifts while ensuring driving comfort.

Besides different shift profiles, *shift adapt control* maintains shift quality over the lifetime of the transmission. By monitoring engine torque, turbine and output speed, the EGS calculates slip time and slip ratio. It then makes necessary adjustments by operating the EDS solenoids to control clutch pressure optimizing shift quality and increasing the life span of the friction plates.

It is imperative that after repairs the shift adapts are reset using a capable scan tool (factory uses a new and improved version of the GT1 which is a computer based diagnostics called DISplus).

There are several strategies used for *Emergency Programs* depending on the type of failure. There could be electrical failures, CAN bus communication failures and mechanical failures.

The use of the Mechatronic Assembly and redundant selector lever inputs (CAN bus and hard wire) aid in reducing the possible faults. Multiple substitute programs are used when a fault does occur in an attempt to prevent further damage to the transmission such as restricted gear selection, restricted shifting and deactivation of all solenoids.

## THE ZF6HP26 TRANSMISSION

### *The Valve Body*

When removing the valve body, BMW says to remove only the green colored bolts. If you are working with a Jaguar unit, the bolts may not be color coded. In these cases you may notice the use of both round and square top bolt heads. Only the square top bolts should be removed to release the valve body assembly from the case (Figure 35).

When splitting the valve body, use the slot shown in Figure 36 to lift the spacer plate and lower valve body off of the upper valve body. The upper valve body (channel plate) contains all the check balls, check valves, damper pistons and screens.

### *The Valve Body Separator Plates*

Referred to as Intermediate Plates have a coating that is damaged during valve body dis-assembly and should be replaced. Available through **ZF** for the 6HP19, 26 & 32 according to transmission tag and valve body code.

**Part: #1068 227 035 01 #1068 227 047 01**

**#1068 227 051 01 #1068 227 052 01**

**#1068 227 053 01**

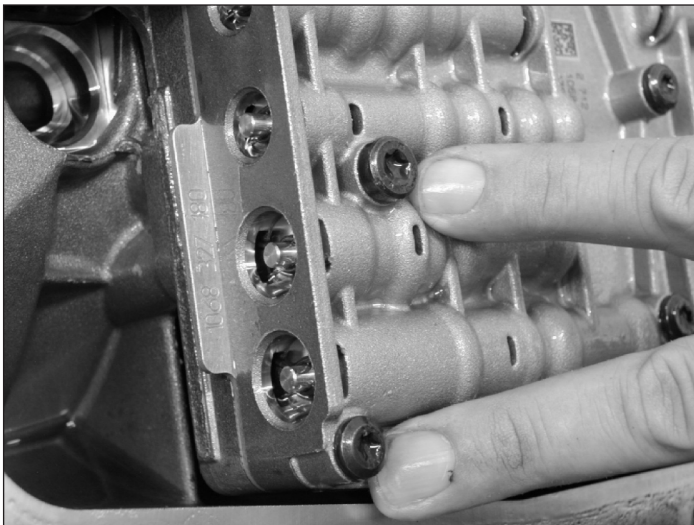

Figure 35

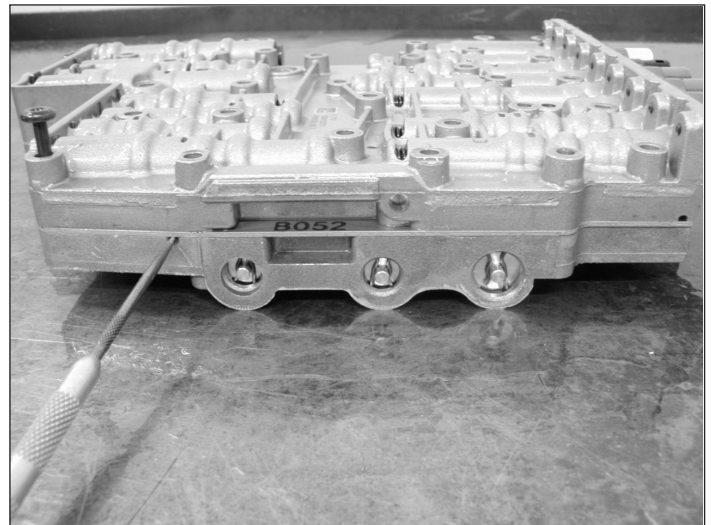

Figure 36

## THE ZF6HP26 TRANSMISSION

### DESCRIPTION OF VALVES

**Manual Valve (M Shift)** - Used for manual gear selection for Park, Neutral, Forward and Reverse.

**Lubricating Valve** - Reduces and guarantees the pressure needed for lubrication. It also imposes an upper limit on the pressure.

**Converter Pressure Valve** - Reduces system pressure and guarantees the pressure needed for the converter. It also limits maximum converter pressure to prevent the converter from expanding. If EDS 6 is actuated, the oil passage behind the converter lock-up piston is vented.

**Main Pressure Regulator Valve** - Regulates the oil pressure built up by the primary pump, excess oil is returned to the pump intake port.

**Converter Lock-up Clutch Valve** - Is controlled jointly with the converter pressure valve by the EDS 6 Solenoid. When the solenoid operates, the direction of flow is reversed. As the converter pressure valve vents the piston chamber behind the lock-up clutch piston, the area in front of the lock-up clutch plate is charged.

**Retaining Valve/Clutch "E", "B", "A" & "D"** - Retaining Valves "E", "B", "A" and "D" prevents the regulating function of clutch valves "E", "B", "A" and "D" during the shift at the appropriate time, so clutch pressure rises to system pressure. Both the retaining valves and the clutch valves are regulated by the corresponding EDS solenoids.

**Clutch Valves "E", "B", "A", "C", "D1" & "D2"** - The Clutch Valves are a variable pressure reducing valve. It is controlled by the relevant EDS Solenoid which determines clutch pressure during the shift.

**Shift Valve 2** - Shift Valve 2 is actuated by solenoid valve 2 and supplies system pressure to operate the relevant clutches.

**Shift Valve 1** - Shift Valve 1 keeps the gear actually selected in use if the power should fail while driving. If the car is restarted and the EGS is in the emergency program, a predetermined gear is selected.

**Pressure Reducing Valve** - The Pressure Reducing Valve lowers system pressure to approximately 73 PSI (5 Bar), which is then applied to the downstream pressure control circuits (EDS 1-6) and solenoid valves (MV1-2). The pressure control circuits and solenoid valves need a constant feed pressure if they are to function properly.

**Position Valve "D" (E Shift Only)** - The Position Valve takes the place of the manual valve and diverts system pressure to regulate the individual friction elements.

**Park Lock Cylinder (E Shift Only)** - The park lock is engaged electrically by the park lock cylinder.

**Parking Lock Valve (E Shift Only)** - The Parking Lock Valve is to shift the park lock cylinder to the neutral or park positions. The parking lock valve is actuated by MV2. MV2 Active = Neutral Position  
MV2 Inactive = Park Position

ZF6HP26 M-SHIFT LOWER VALVE BODY

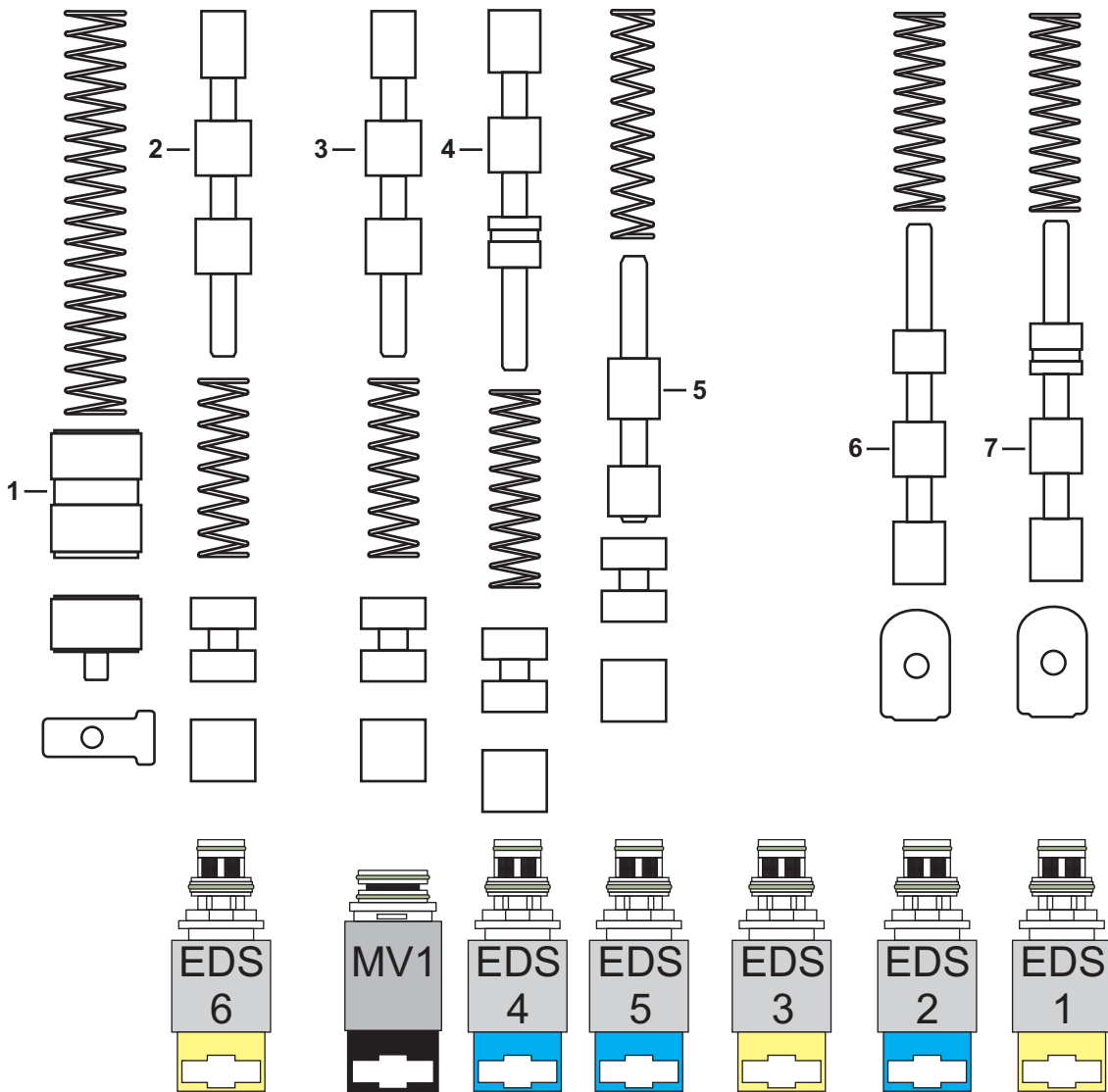
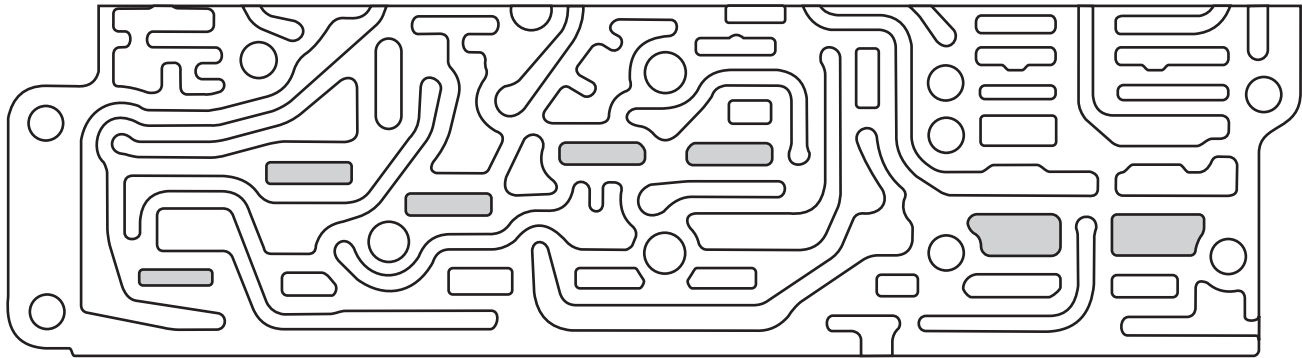

- 1. MV1 Solenoid Damper
- 2. Shift Valve 2
- 3. Shift Valve 1
- 4. Holding Valve D1

- 5. Solenoid Feed Limit Valve
- 6. Holding Valve B
- 7. Holding Valve A

\* Shaded area in the valve body indicate retainer location

Figure 37  
Automatic Transmission Service Group

ZF6HP26 M-SHIFT LOWER VALVE BODY

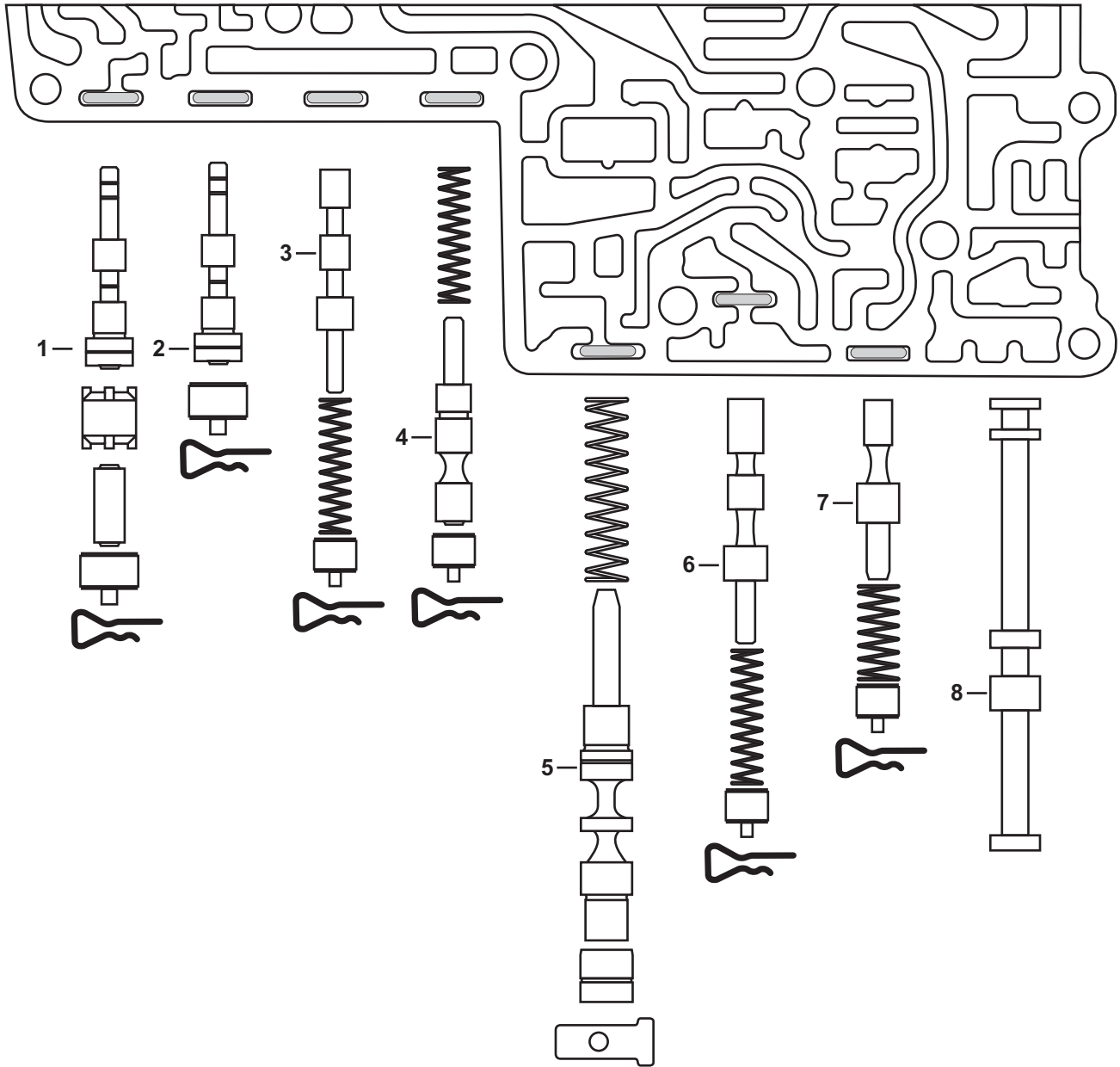

- 1. Clutch Valve A
- 2. Clutch Valve E
- 3. Holding Valve E
- 4. TCC Regulator Valve

- 5. Pressure Regulator Valve
- 6. TCC Switch Valve
- 7. Lubrication/Cooler Valve
- 8. Manual Valve

\* Shaded area in the valve body indicate retainer location

Figure 38  
Automatic Transmission Service Group

ZF6HP26 M-SHIFT UPPER (CHANNEL PLATE) VALVE BODY

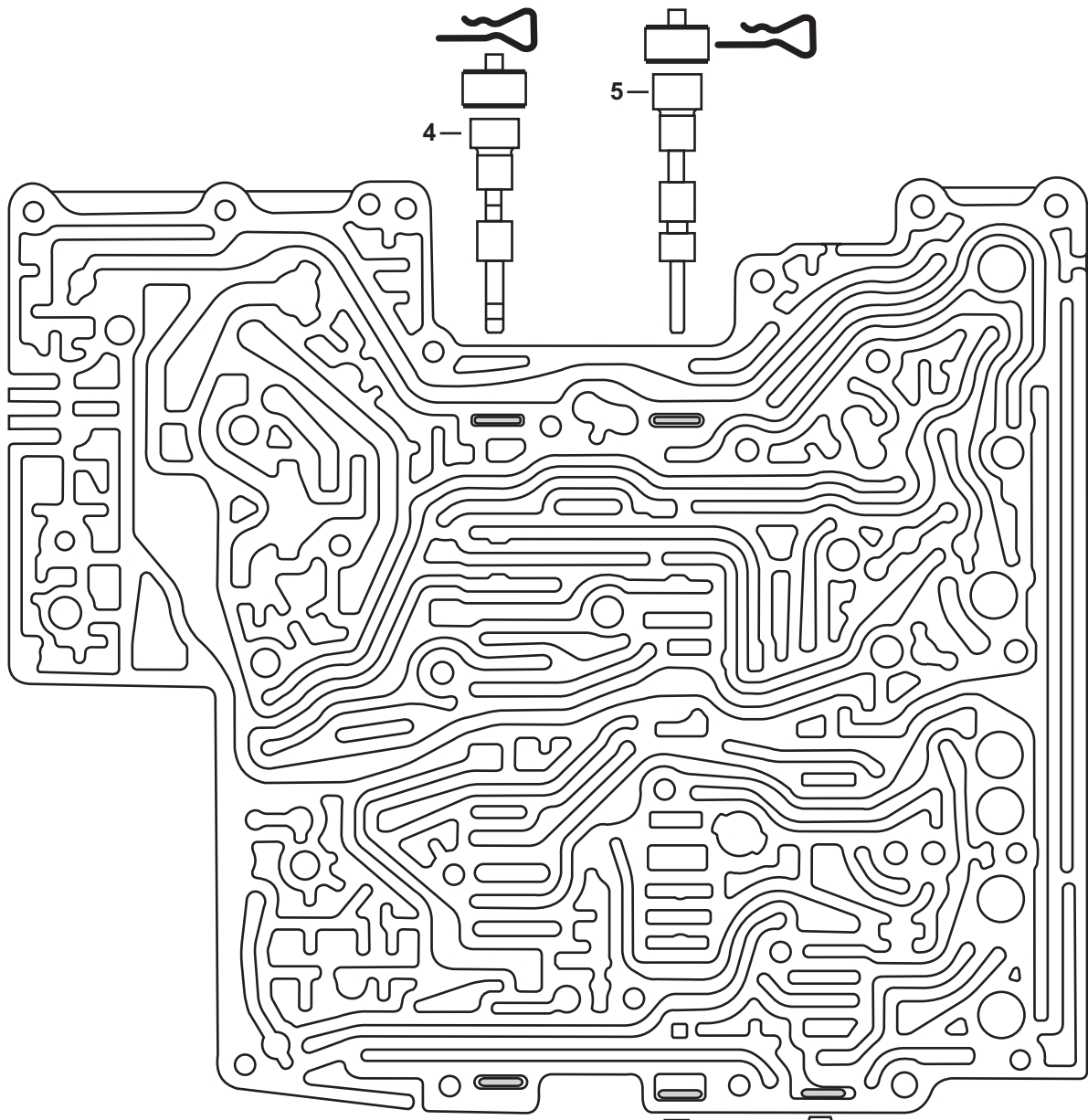

- 1. Holding Valve D2
- 2. Clutch Valve D2
- 3. Clutch Valve B
- 4. Clutch Valve D1
- 5. Clutch Valve C

\* Shaded area in the valve body indicate retainer location

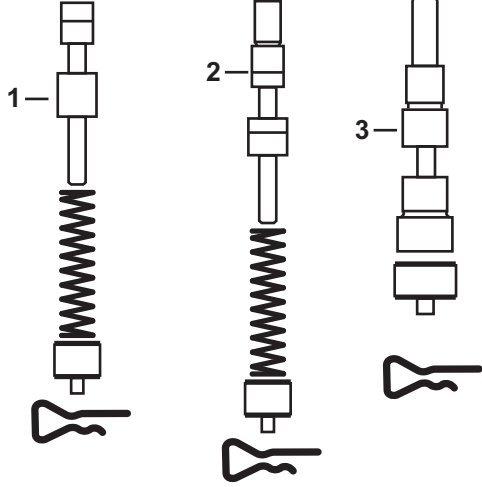

**Special note: All printed materials reveal a spring being used for each of the valves 3, 4 and 5. This Jaguar VB did not.**

Figure 39  
Automatic Transmission Service Group



ZF6HP26 E-SHIFT LOWER VALVE BODY

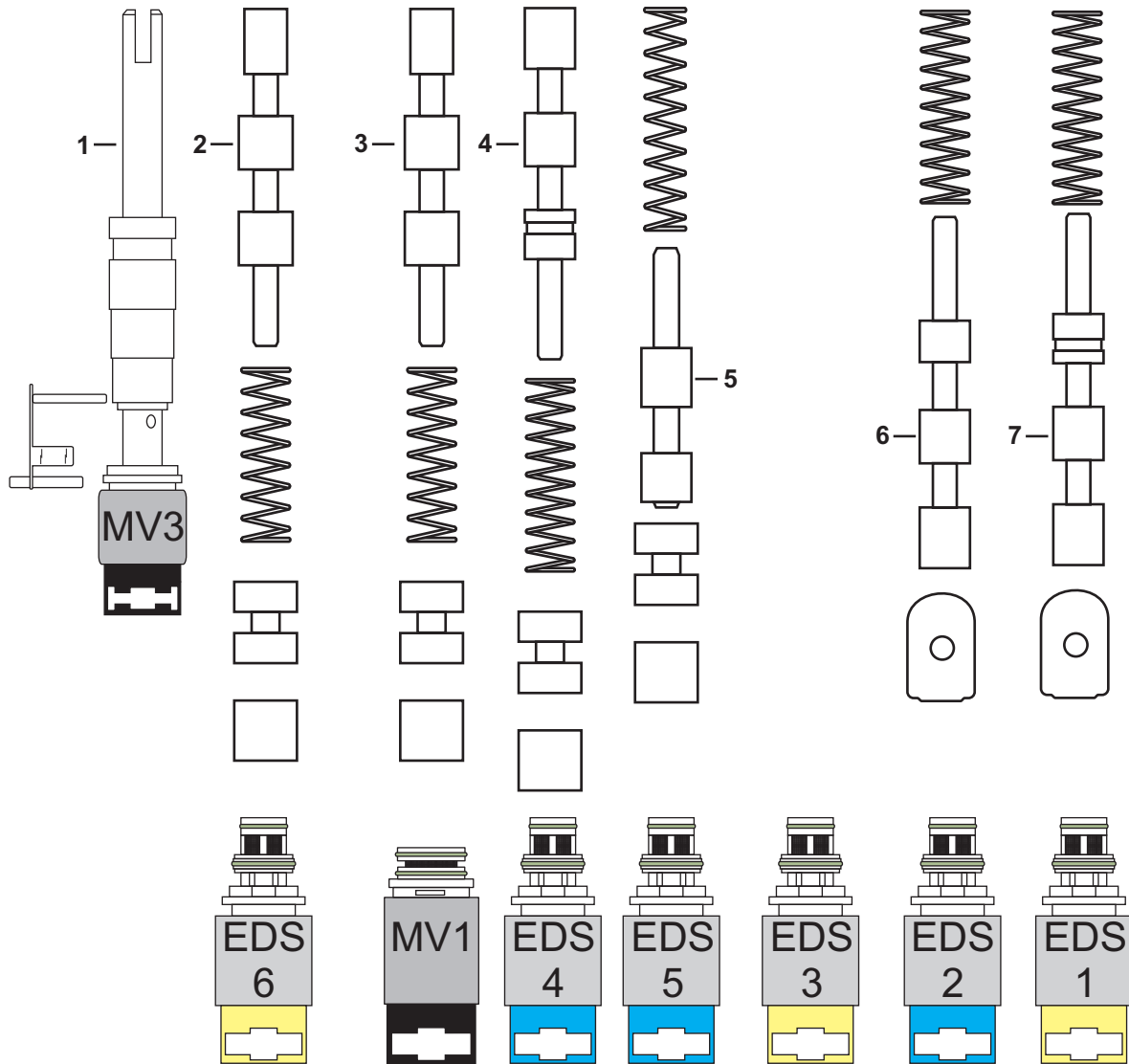
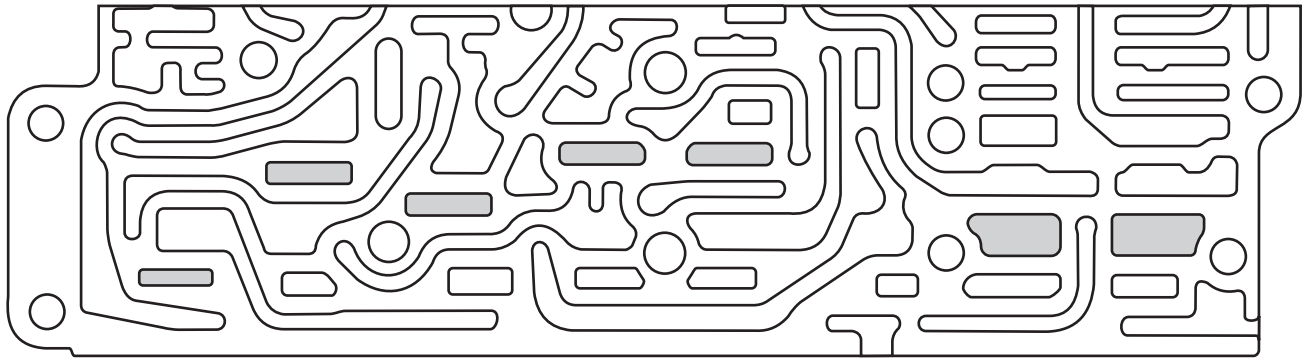

- 1. MV3 Solenoid Valve/Park Lock Cylinder
- 2. Shift Valve 2
- 3. Shift Valve 1
- 4. Holding Valve D1

- 5. Pressure Reducing Valve
- 6. Holding Valve B
- 7. Holding Valve A

\* Shaded area in the valve body indicate retainer location

Copyright © 2008 ATSG

Figure 40  
Automatic Transmission Service Group

ZF6HP26 E-SHIFT LOWER VALVE BODY

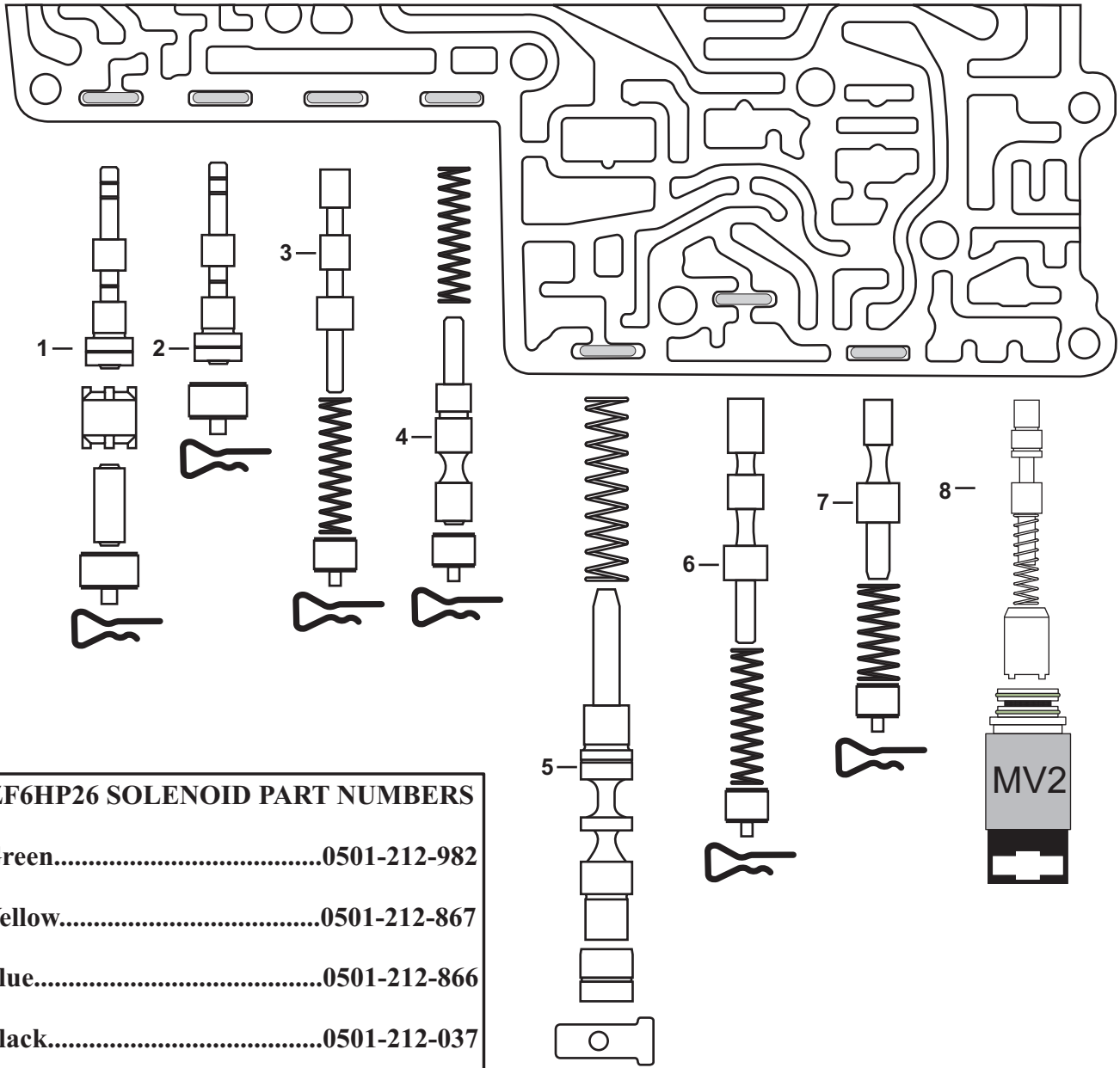

ZF6HP26 SOLENOID PART NUMBERS	
Green.....	0501-212-982
Yellow.....	0501-212-867
Blue.....	0501-212-866
Black.....	0501-212-037

- |                             |  |
|-----------------------------|--|
| 1. Clutch Valve A           | 6. Converter Pressure Valve                                |
| 2. Clutch Valve E           | 7. Lubrication/Cooler Valve                                |
| 3. Holding Valve E          | 8. Park Lock Valve   |
| 4. TCC Regulator Valve      | 9. MV 2 Solenoid Valve                                     |
| 5. Pressure Regulator Valve | * Shaded area in the valve body indicate retainer location |

Figure 41  
Automatic Transmission Service Group

ZF6HP26 E-SHIFT UPPER (CHANNEL PLATE) VALVE BODY

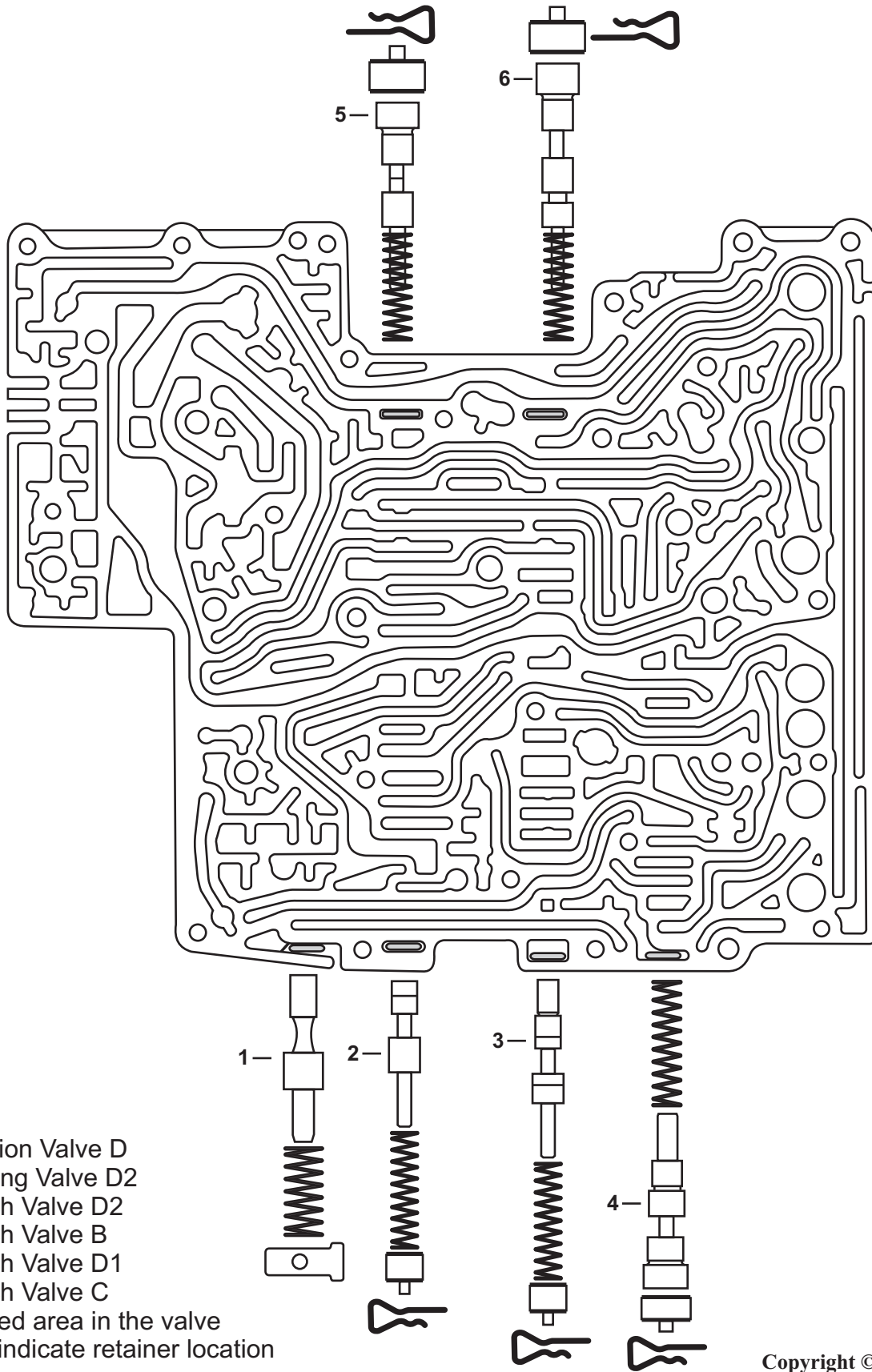

Figure 42  
 Automatic Transmission Service Group

**BMW/JAGUAR  
ZF6HP26 "M" SHIFT  
UPPER VALVE BODY**

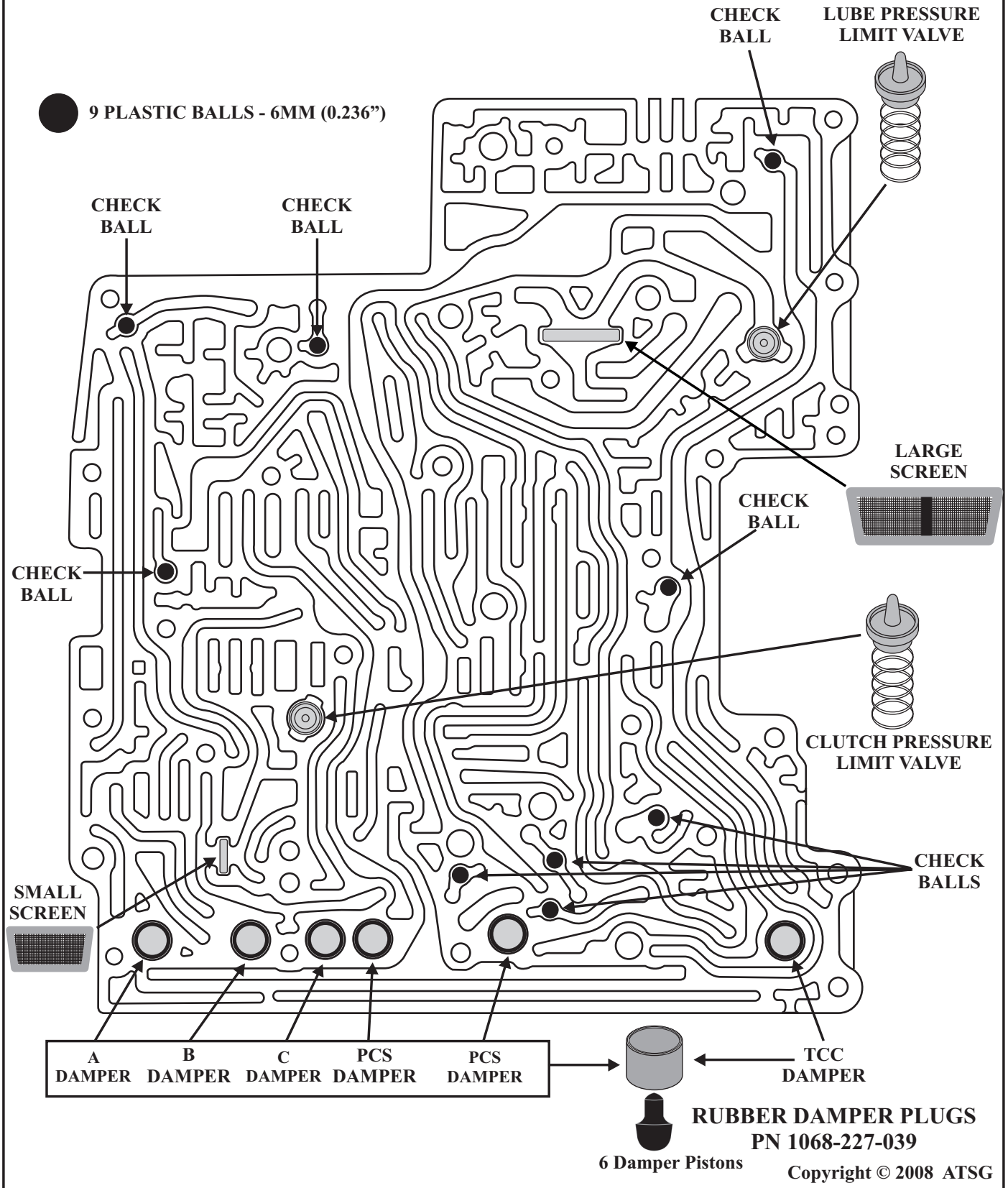

Figure 43  
Automatic Transmission Service Group

**BMW  
ZF6HP26 "E" SHIFT  
UPPER VALVE BODY**

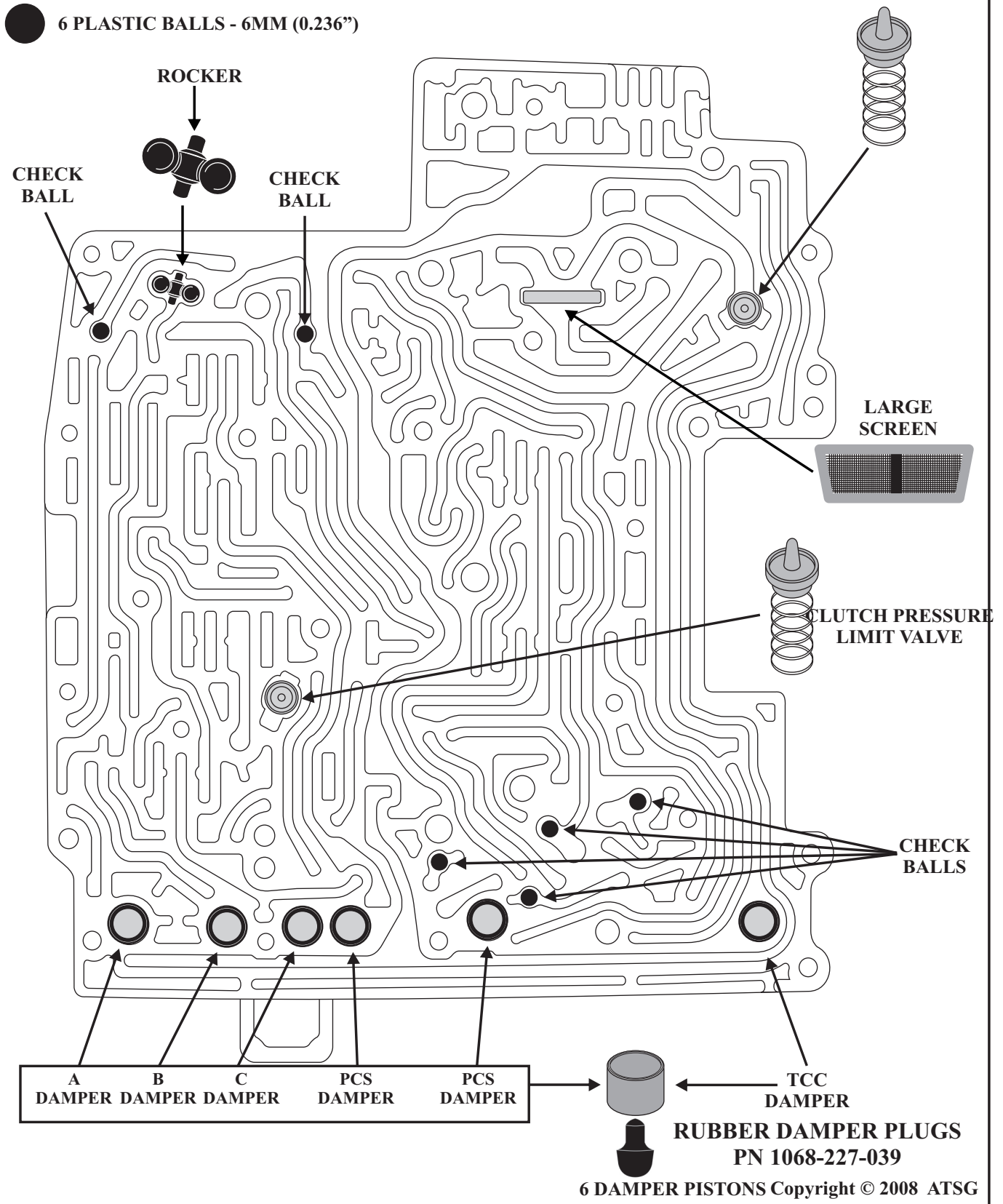
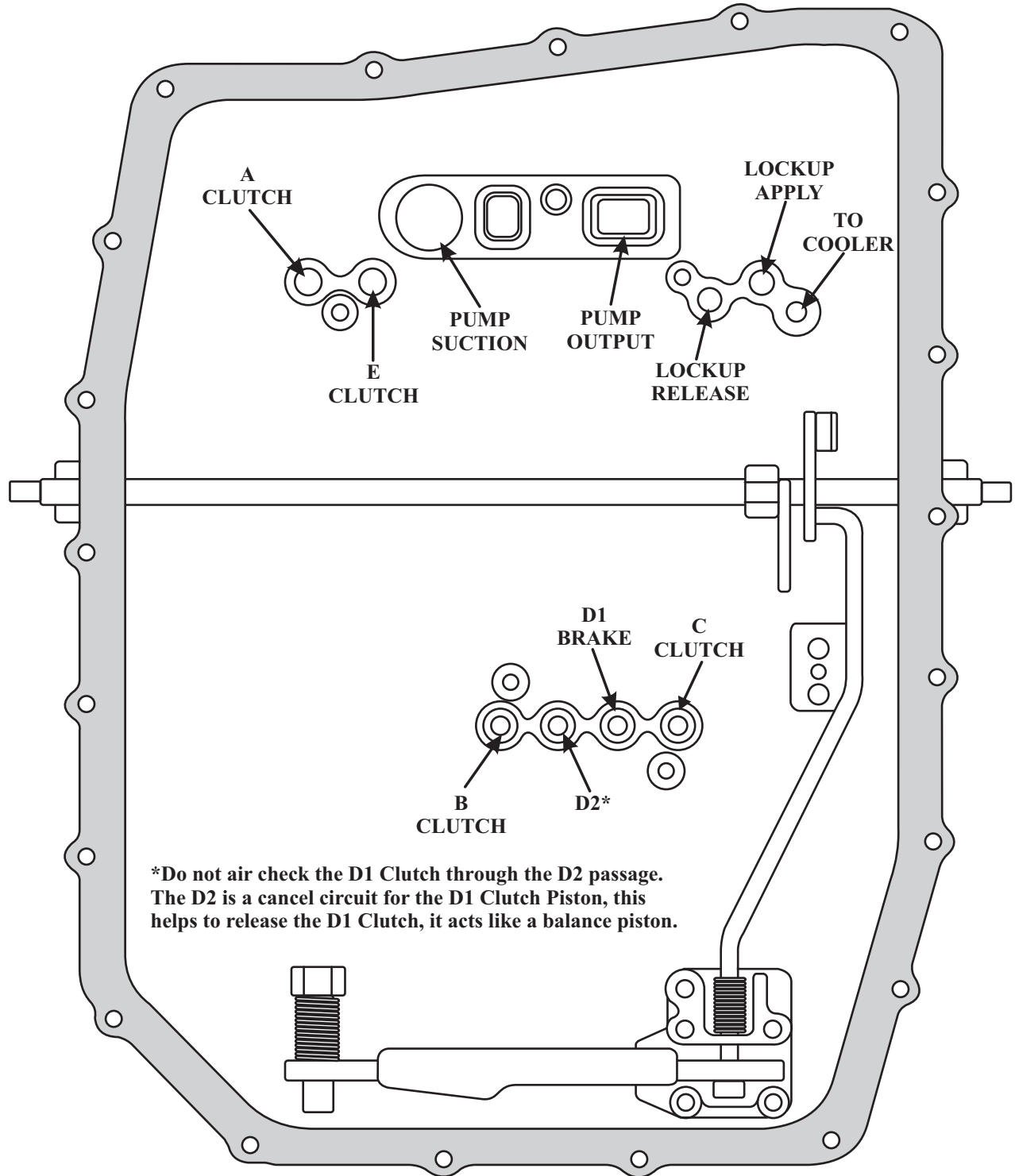

Figure 44  
Automatic Transmission Service Group

ZF6HP26  
CASE PASSAGE IDENTIFICATION



**\*Do not air check the D1 Clutch through the D2 passage. The D2 is a cancel circuit for the D1 Clutch Piston, this helps to release the D1 Clutch, it acts like a balance piston.**

Figure 45  
Automatic Transmission Service Group

*Reverse Hydraulic for E Shift Unit*

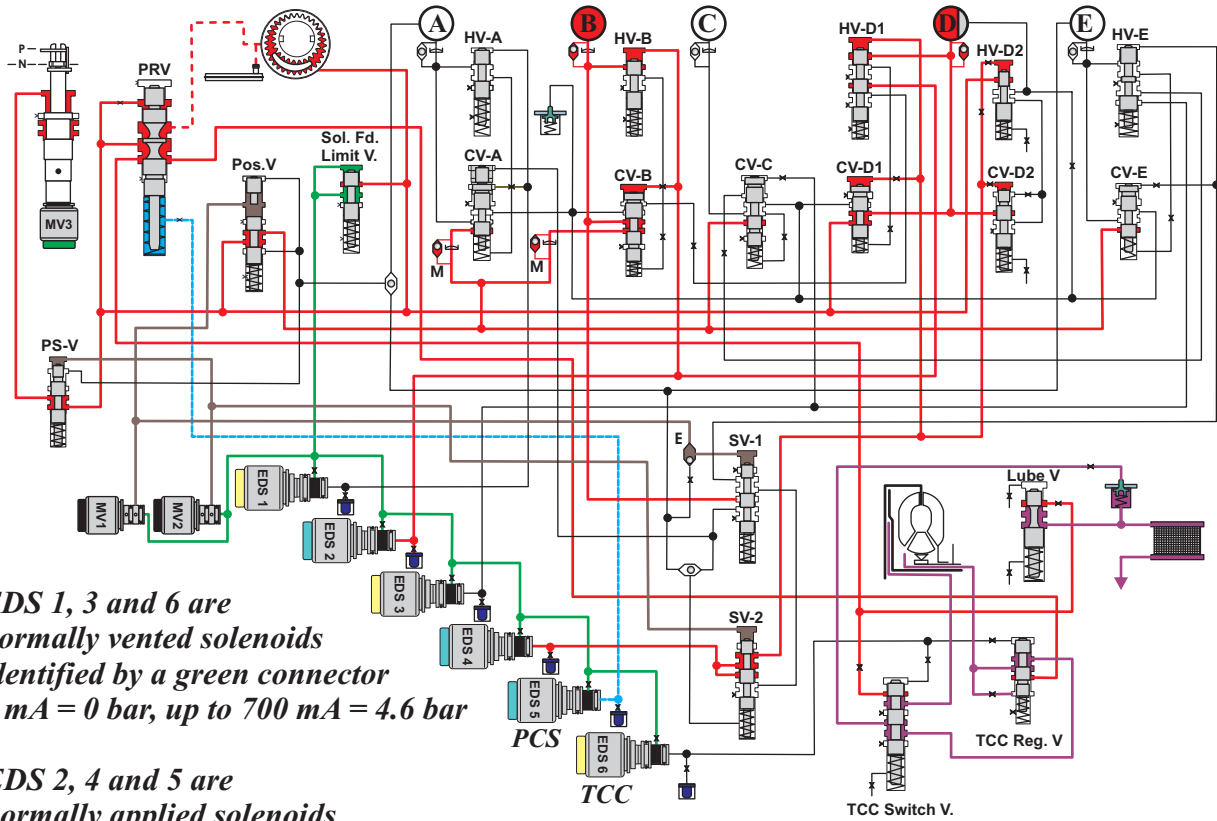

*EDS 1, 3 and 6 are normally vented solenoids identified by a green connector  
0 mA = 0 bar, up to 700 mA = 4.6 bar*

*EDS 2, 4 and 5 are normally applied solenoids identified by a blue connector  
0 mA = 4.6 bar, up to 700 mA = 0 bar*

	MV			EDS					
	1	2	3	NV-1	NA-2	NV-3	NA-4	NA-5	NV-6
<b>Park</b>							X	X*	
<b>Reverse</b>	X	X	X					X*	
<b>Neutral</b>	X	X	X				X	X*	
<b>D 1st gear</b>	X	X	X	X	X			X*	X*
<b>D 2nd gear</b>	X	X	X	X	X	X	X	X*	X*
<b>D 3rd gear</b>			X	X			X	X*	X*
<b>D 4th gear</b>	X		X	X	X			X*	X*
<b>D 5th gear</b>	X		X					X*	X*
<b>D 6th gear</b>	X		X		X	X		X*	X*

Figure 46

*1st gear hydraulic for E Unit*

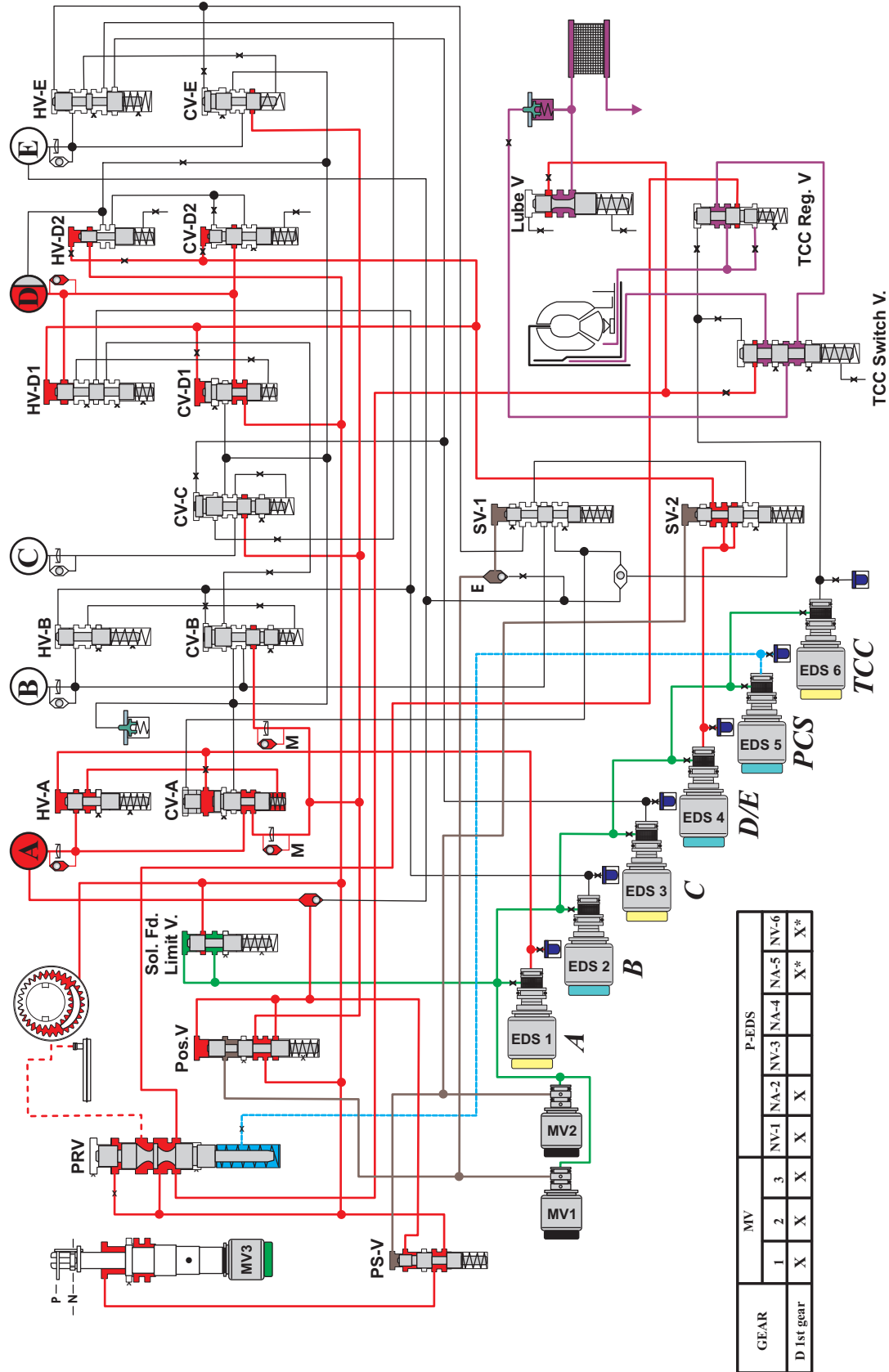

GEAR	MV	P-EDS									
		1	2	3	NV-1	NA-2	NV-3	NA-4	NA-5	NV-6	
D 1st gear		X	X	X	X	X				X*	X*

In first gear all of the normally vented MV solenoids are energized supplying pressure to their respective circuits.  
 EDS 1 which is a normally vented solenoid is energized supplying pressure to its respective circuit.  
 EDS 2 which is a normally applied solenoid is energized blocking pressure from its respective circuit.  
 EDS 3 which is a normally vented solenoid is not energized venting pressure from its respective circuit.  
 EDS 4 which is a normally applied solenoid is not energized supplying pressure to its respective circuit.

Figure 47  
 Automatic Transmission Service Group



2nd gear hydraulic for E Unit

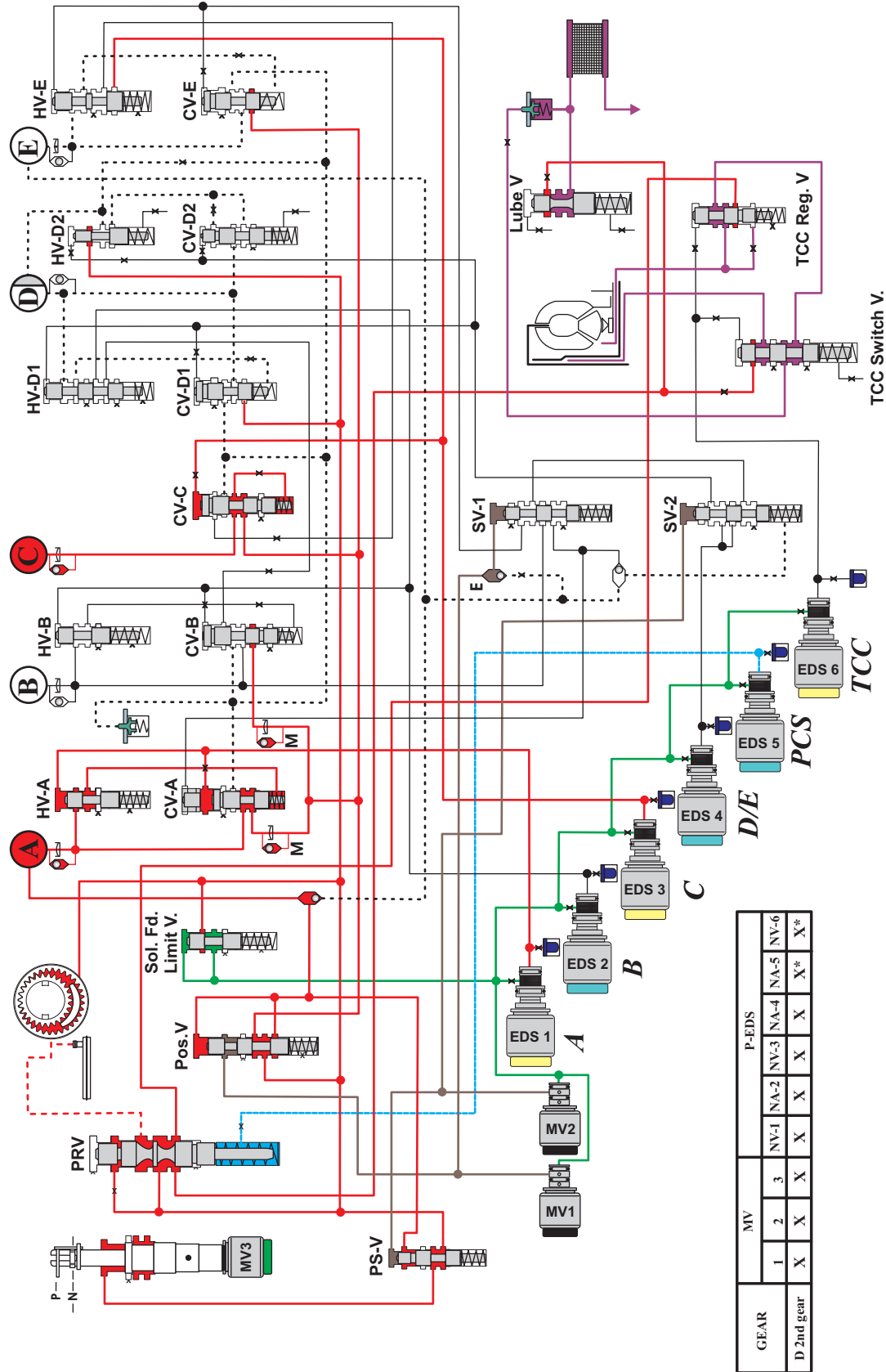

In second gear all of the normally vented MV solenoids are energized supplying pressure to their respective circuits.  
 EDS 1 which is a normally vented solenoid is energized supplying pressure to its respective circuit.  
 EDS 2 which is a normally applied solenoid is energized blocking pressure from its respective circuit.  
 EDS 3 which is a normally vented solenoid is energized supplying pressure to its respective circuit.  
 EDS 4 which is a normally applied solenoid is energized blocking pressure to its respective circuit.

Figure 48  
 Automatic Transmission Service Group

3rd gear hydraulic for E Unit

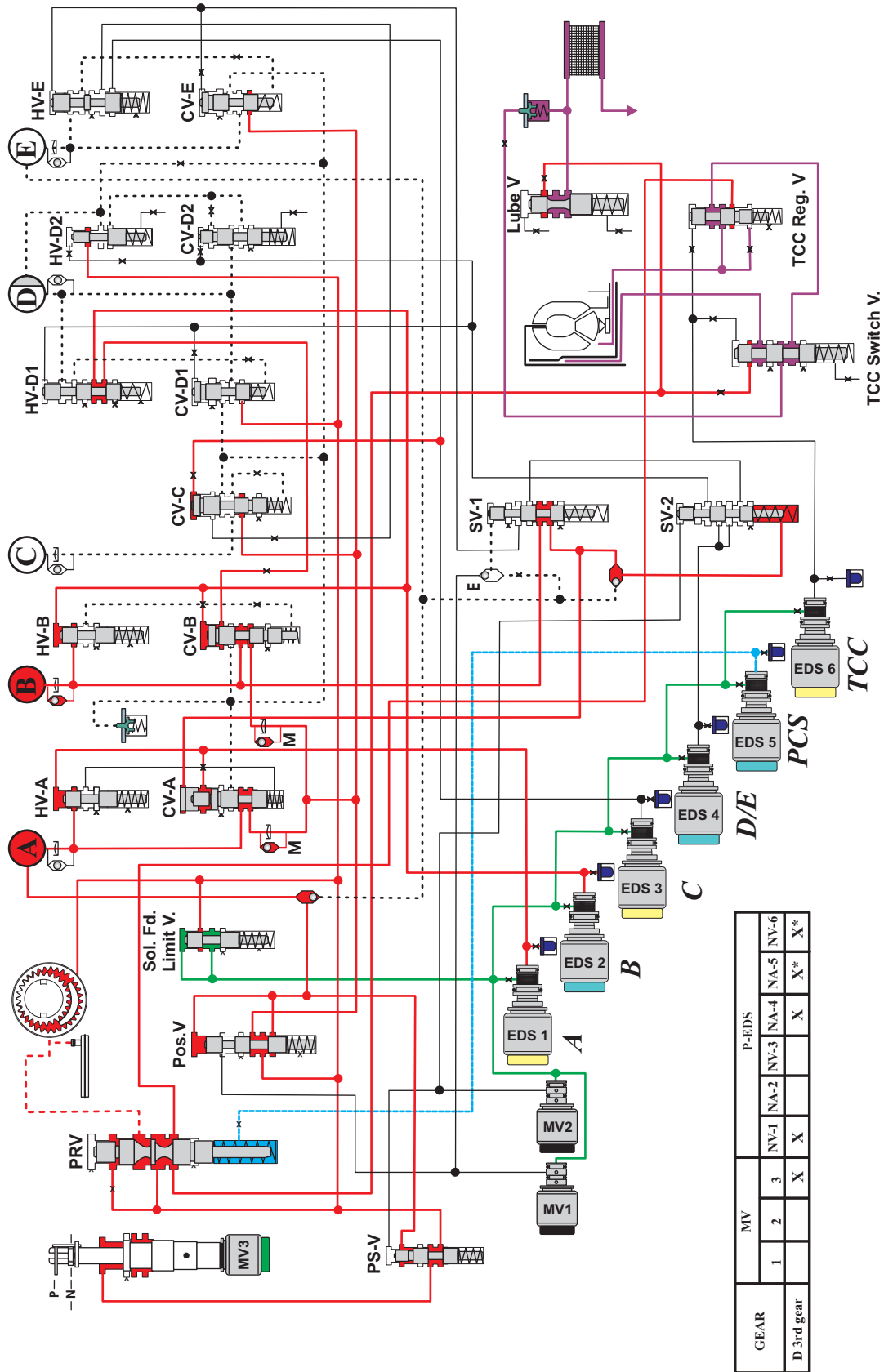

In third gear normally vented MV solenoids 1 and 2 turn off venting their circuits while 3 remains energized. EDS 1 which is a normally vented solenoid is energized supplying pressure to its respective circuit. EDS 2 which is a normally applied solenoid is not energized supplying pressure to its respective circuit. EDS 3 which is a normally vented solenoid is not energized exhausts pressure to its respective circuit. EDS 4 which is a normally applied solenoid is energized blocking pressure to its respective circuit.

Figure 49

4th gear hydraulic for E Unit

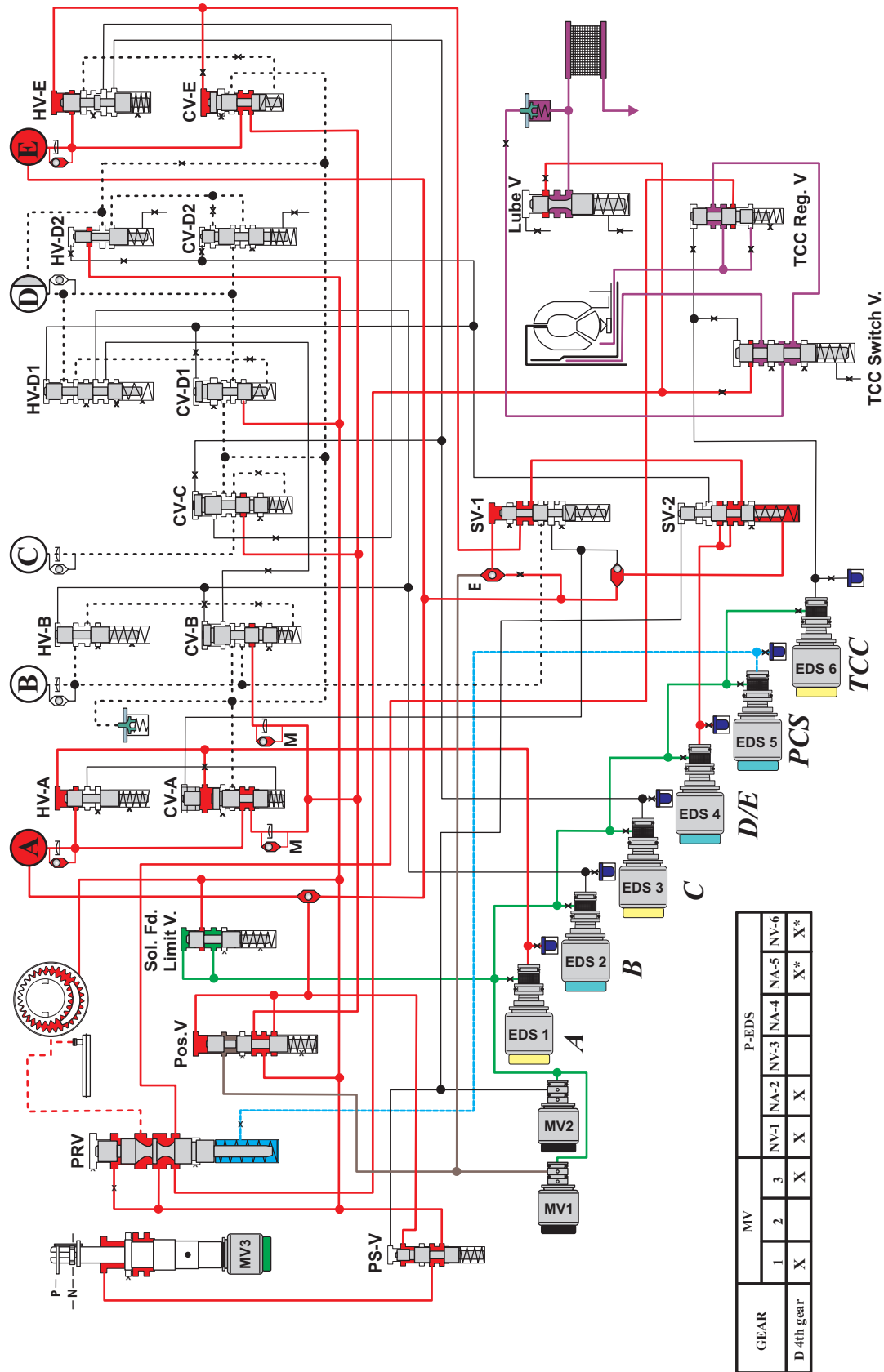

GEAR	MV	P-EDS									
		1	2	3	NA-1	NA-2	NA-3	NA-4	NA-5	NA-6	
D 4th gear		X		X	X	X				X*	X*

In fourth gear normally vented MV solenoid 2 remains off venting its circuit while 1 and 3 are energized.  
 EDS 1 which is a normally vented solenoid is energized supplying pressure to its respective circuit.  
 EDS 2 which is a normally applied solenoid is energized blocking pressure from its respective circuit.  
 EDS 3 which is a normally vented solenoid is not energized exhausting pressure from its respective circuit.  
 EDS 4 which is a normally applied solenoid is not energized supplying pressure to its respective circuit.

Figure 50  
Automatic Transmission Service Group

5th gear hydraulic for E Unit

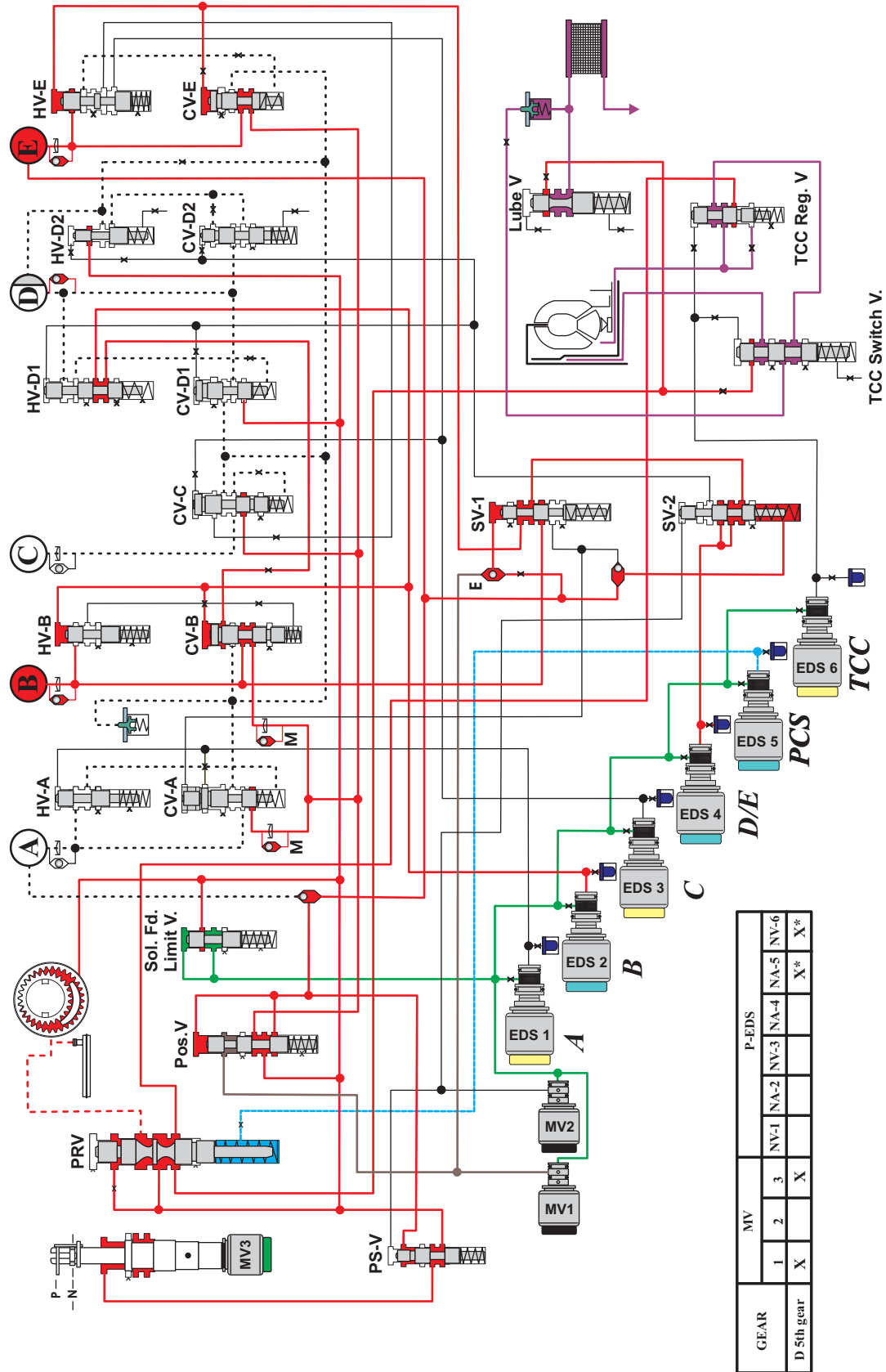

GEAR	MV	P-EDS										
		1	2	3	NA-1	NA-2	NA-3	NA-4	NA-5	NA-6		
D 5th gear		X									X*	X*

In fifth gear normally vented MV solenoid 2 remains off venting its circuit while 1 and 3 are energized.  
 EDS 1 which is a normally vented solenoid is not energized exhausting pressure from its respective circuit.  
 EDS 2 which is a normally applied solenoid is not energized supplying pressure to its respective circuit.  
 EDS 3 which is a normally vented solenoid is not energized exhausting pressure from its respective circuit.  
 EDS 4 which is a normally applied solenoid is not energized supplying pressure to its respective circuit.

Figure 51  
 Automatic Transmission Service Group

6th gear hydraulic for E Unit

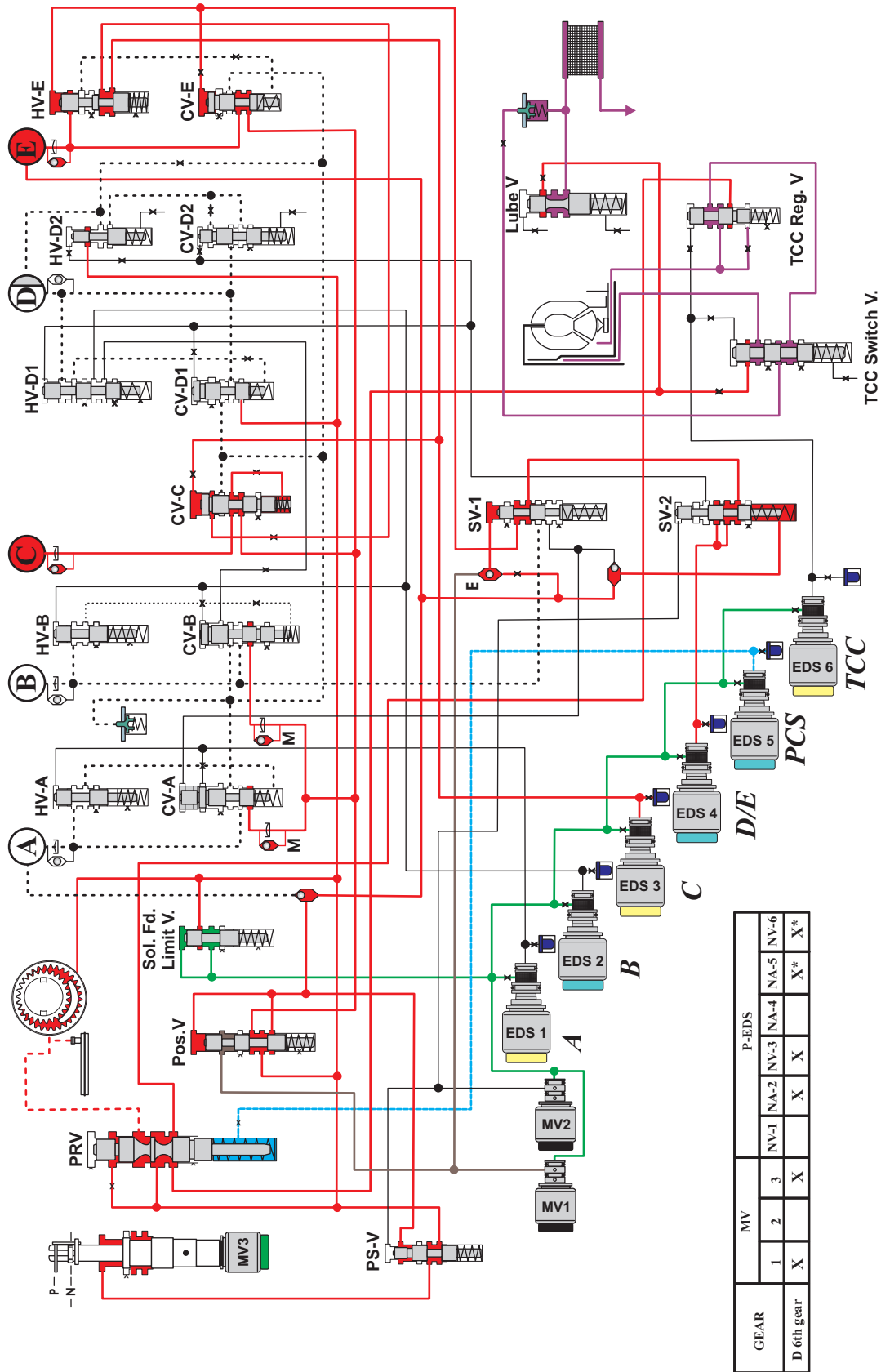

In sixth gear normally vented MV solenoid 2 remains off venting its circuit while 1 and 3 are energized.  
 EDS 1 which is a normally vented solenoid is not energized exhausting pressure from its respective circuit.  
 EDS 2 which is a normally applied solenoid is energized blocking pressure from its respective circuit.  
 EDS 3 which is a normally vented solenoid is energized supplying pressure to its respective circuit.  
 EDS 4 which is a normally applied solenoid is not energized supplying pressure to its respective circuit.

Figure 52  
 Automatic Transmission Service Group

<i>Driving situation Fault/consequences</i>	<i>Check Control Message</i>	<i>Supplemental Information in the control display</i>
Temperature in gearbox high	Transmission Overheated! Drive moderately	Reverts to default shift program, reduce response. Avoid high speeds and engine loads.
Temperature in gearbox very high	Transmission Stop vehicle carefully	Transmission overheated. Move selector lever to pos. P. Leave engine running. Allow trans to cool then carefully cont. driving if problem persist, contact BMW Retail Center.
Selector lever CAN fault	Transmission Fault! Drive moderately	Limited transmission operation Danger of complete trans. Failure! Please contact the nearest BMW Center.
Key signal, invalid CAS, CAN fault, P-Magnet short to positive or open circuit, parking lock engaged incorrectly	Trans. Range N only with engine on!	The transmission automatically shifts to P when the engine is switched off. Please contact your BMW Center as soon as possible.
Pos. P mechanical emergency operation active (also applies to emergency operation triggered in Pos. R and N)	Gearbox defective Transmission Fault!	The fault may be resolved by restarting engine. Contact the nearest BMW Center if necessary. Use emergency release to disengage park detent prior to towing or pushing vehicle.
Engine speed invalid ECM CAN fault	Transmission Failsafe! Drive moderately	Only P,R,N,D3 and D5 available Ranges may be engaged without depressing brake. Please contact nearest BMW Retail Center. Have checked by nearest BMW Retail Center.

<i>Driving situation Fault/consequences</i>	<i>Check Control Message</i>	<i>Supplemental Information in the control display</i>
Gear monitoring and shift monitoring	Gearbox position R. Transmission range R, Fault!	Reverse gear cannot be engaged. It may be impossible to select R. Reduce acceleration. Please contact the nearest BMW Center.
Short to ground of an MV, EPS mechanical emergency operation and Pos. D Selector level signal fault (CAN and serial line)	Transmission range P, R, N Fault!	Only transmission range D is available. P engages auto. When engine is switched off. Please contact the nearest BMW Retail Center.
V>3km/h, P-push-button invalid. P-sensor implausible	Trans. In P only when stationary!	Limited transmission operation Danger of complete trans. Failure! Please contact the nearest BMW Center.
Signal from P-push-button invalid. P-sensor implausible	Trans. Range P fault!	Transmission range P may be unavailable. Engage parking brake when vehicle is stationary Please contact the nearest BMW Retail Center.
Parking lock does not engage, possible P-sensor fault, emergency release activated.	Gearbox in position N! Transmission in position N!	Gearbox position P is engaged Transmission automatically shifts into P when the remote control unit is extracted from the ignition lock or once 30 minutes have elapsed.
Indicate in N-hold phase with door open or seat occupancy = 0 indication in H-hold phase with selector lever operation D, R and N detected.	Transmission in position N!	Gearbox position P is engaged Transmission automatically shifts into P when remote control unit is extracted from the ignition lock or 30 minutes have elapsed.
EGS CAN interface defective (gearbox fault probably) instrument cluster cannot receive valid display message from EGS. Passive message from instrument cluster.	Transmission Fault! Drive moderately	No transmission display. Poss. Reduction of gear selections. Possible to select new gears without depressing the brake. Please contact the nearest BMW Center.

<i>Driving situation Fault/consequences</i>	<i>Check Control Message</i>	<i>Supplemental Information in the control display</i>
Indicate at terminal 15 on and door open or seat occupancy = 0	Gearbox in position N! Transmission in position N!	Gearbox position P is engaged.
Shift lock note	To engage gear brake	Only transmission range D is available. P engages auto. When engine is switched off. Please contact the nearest BMW Retail Center.
Brake signal invalid Brake signal implausible	Gear engage without brake possible!	Before engaging gear, press brake. When leaving the vehicle, switch off the engine. Accident Hazard! Please contact your BMW Retail Center as soon as possible.
Indication in the event of sloppy operation or P-push-button faulty	Repeat gear selection	Transmission range P may be unavailable. Engage parking brake when vehicle is stationary Please contact the nearest BMW Retail Center.
Message before N-hold phase elapse (30 minutes)	Transmission position P engaging!	To maintain transmission range N, press selector lever within 10 seconds to position N.
Gear monitoring Shift monitoring	Transmission Failsafe! Drive moderately	Transmission failsafe program Possible reduced acceleration. Please contact the nearest BMW Center.
Ignition on and N engine = 0 and gearbox Position P and selector lever push to N.	Position R, N, D only within engine on.	



DTC	DTC DESCRIPTION	COMMENTS
P0605	EPROM FLASH, Checksum	New TCM and Valvebody
P0606	Watchdog locking mechanism	New TCM and Valvebody
P0610	Incorrect configuration or calibration loaded	Should never be seen - mismatch with ECM and TCM
P0641	Sensor supply voltage	New TCM and Valvebody
P0651	EDS and MV solenoid supply	New TCM and Valvebody
P0666	Substrate Temp. Sensor open or short circuit	New TCM and Valvebody
P0701	Combination of impossible substitute functions	You will see another code as well (ATF or OSS)
P0702	Undervoltage	Engine must be running to log code - charging fault
P0705	Position switch open or short circuit	New TCM and Valvebody
P0706	Implausible J Gate Position (Jaguar)	No manual side operation of J-Gate-test J-Gate - check cable set up
P0709	Intermediate position	Should not be seen
P0710	Fluid Temp Sensor open or short circuit	New TCM and Valvebody
P0711	Fluid Temp Monitoring out of range	New TCM and Valvebody
P0715	Turbine Speed Signal open or short circuit	New TCM and Valvebody
P0720	Output Speed Signal open or short circuit	Compare output speed with wheel speed - New TCM and Valvebody
P0721	Reverse Gear Ratio Error	Output speed gradient fault
P0729	6 <sup>th</sup> Gear Ratio Error	Check oil level and condition - replace transmission
P0730	Gear Ratio Fault	Check oil level and condition - replace transmission
P0731	1 <sup>st</sup> Gear Ratio Error	Check oil level and condition - replace transmission
P0732	2 <sup>nd</sup> Gear Ratio Error	Check oil level and condition - replace transmission
P0733	3 <sup>rd</sup> Gear Ratio Error	Check oil level and condition - replace transmission
P0734	4 <sup>th</sup> Gear Ratio Error	Check oil level and condition - replace transmission
P0735	5 <sup>th</sup> Gear Ratio Error	Check oil level and condition - replace transmission
P0736	Reverse Gear Ratio Error	Incorrect ratio calculated for revers - check oil level and condition - replace transmission

P0740	EDS 6 solenoid open or short circuit	New TCM and Valvebody
P0741	TCC stuck open, excessive slip	New TCM and Valvebody
P0743	EDS 6 performance fault	New TCM and Valvebody
P0750	EDS 1 solenoid open or short circuit	New TCM and Valvebody
P0753	EDS 1 solenoid performance fault	New TCM and Valvebody
P0755	EDS 2 solenoid open or short circuit	New TCM and Valvebody
P0758	EDS 2 solenoid performance fault	New TCM and Valvebody
P0760	EDS 3 solenoid open or short circuit	New TCM and Valvebody
P0763	EDS 3 solenoid performance fault	New TCM and Valvebody
P0765	EDS 4 solenoid open or short circuit	New TCM and Valvebody
P0768	EDS 4 solenoid performance fault	New TCM and Valvebody
P0770	EDS 5 solenoid open or short circuit	New TCM and Valvebody
P0773	EDS 5 solenoid performance fault	New TCM and Valvebody
P0780	Car load fault, incorrect calculation during shift	Check oil level and condition - replace transmission
P0781	Gear load 1-2 or 2-1	Check oil level and condition - replace transmission
P0782	Gear load 2-3 or 3-2	Check oil level and condition - replace transmission
P0783	Gear load 3-4 or 4-3	Check oil level and condition - replace transmission
P0784	Gear load 4-5 or 5-4	Check oil level and condition - replace transmission
P0787	MV1 solenoid open or short circuit	New TCM and Valvebody
P0788	MV1 solenoid performance fault	New TCM and Valvebody
P0825	J Gate Plausibility in position R/D (Jaguar)	Test J-Gate (Jaguar)
P0829	Gear load 5-6 or 6-5	Check oil level and condition - replace transmission
P1571	Brake Pedal Signal	Test ECM Inputs
P1603	EEPROM Communications internal error	Clear code first and retry - New TCM and Valvebody
P1605	Battery buffered RAM'	New TCM and Valvebody
P1749	P and N signal invalid	Carry out pin pint test-used by EMS for starting
P1774	CAN message J-Gate time-out (Jaguar)	Check network
P1783	Over Temperature Shut down	Check for cause of overheating
P1794	Power supply open or short circuit	Check fuse feed etc.
P1796	CAN bus off, network fault	Harness or Module
P1797	CAN timeout EMS	Check network
P1798	CAN timeout INST	Check network
P1799	CAN timeout ABS	Check network

P Code	Code Description	BMW-FC
P0715	Input/Turbine Speed Sensor 'A' Circuit	20200
P0720	Output Speed Sensor Circuit	20201
P0731	Gear 1 Incorrect Ratio	20301
P0732	Gear 2 Incorrect Ratio	20302
P0733	Gear 3 Incorrect Ratio	20303
P0734	Gear 4 Incorrect Ratio	20304
P0735	Gear 5 Incorrect Ratio	20305
P0740	Torque Converter Clutch Circuit/Open	20005
P0741	Torque Converter Clutch Circuit Performance or Stuck Off	20307
P0743	Torque Converter Clutch Circuit Electrical	20005
P0745	Pressure Control Solenoid 'A'	20000
P0748	Pressure Control Solenoid 'A' Electrical	20000
P0751	Shift Solenoid 'A' Performance or Stuck Off	20100
P0753	Shift Solenoid 'A' Electrical	20100
P0756	Shift Solenoid 'B' Performance or Stuck Off	20101
P0758	Shift Solenoid 'B' Electrical	20101
P0761	Shift Solenoid 'C' Performance or Stuck Off	20102
P0763	Shift Solenoid 'C' Electrical	20102
P0775	Pressure Control Solenoid 'B'	20001
P0778	Pressure Control Solenoid 'B' Electrical	20001
P0781	1-2 Shift	20311
P0782	2-3 Shift	20312
P0783	3-4 Shift	20313
P0784	4-5 Shift	20314
P0795	Pressure Control Solenoid 'C'	20002
P0798	Pressure Control Solenoid 'C' Electrical	20002
P1701	Double Error Position Information CAN / Serial Line	20700
P1702	Combination Substitute Function	20701
P1720	CAN Timeout Control Module	20800
P1721	CAN Timeout ASC/DSC	20801
P1727	CAN Engine Speed	20903
P1728	Engine Over-speed Condition	20336
P1736	Gear 6 Incorrect Ratio	20306
P1743	Pressure Control Solenoid 'E' Electrical (M44/M52: Brake Band Electrical)	20004
P1745	Pressure Control Solenoid 'E'	20004
P1747	CAN-BUS Monitoring	52999
P1753	Pressure Control Solenoid 'D' Electrical	20003
P1755	Pressure Control Solenoid 'D'	20003
P1771	CAN Torque Interface Plausibility	20901
P1790	Internal Transmission Control Module Memory Checksum/EPROM Error	20400
P1791	Internal Transmission Control Module Memory Checksum/EEPROM Error	20401
P1792	Internal Transmission Control Module Watchdog Error	20402
P1793	ETC Cut-Off due to Over-temperature Condition	20330
P1801	Shift Solenoid 'A' Low Input	20100
P1802	Shift Solenoid 'B' Low Input	20101
P1803	Shift Solenoid 'C' Low Input	20102
P1806	Shift Solenoid 'A' or 'B' Mechanically Stuck	20105
P1810	Input/Turbine Speed Sensor Circuit High	20200



P Code	Code Description	BMW-FC
P1811	Input/Turbine Speed Sensor Circuit Low	20200
P1812	Output Speed Sensor Circuit High Input	20201
P1813	Output Speed Sensor Circuit Low Input	20201
P1814	Output Speed Sensor Gradient Too High	20203
P1830	Pressure Control Solenoid Current Error in P/R/N	20006
P1831	Pressure Control Solenoid 'A' Circuit High	20000
P1832	Pressure Control Solenoid 'B' Circuit High	20001
P1833	Pressure Control Solenoid 'C' Circuit High	20002
P1834	Pressure Control Solenoid 'D' Circuit High	20003
P1835	Pressure Control Solenoid 'E' Circuit High	20004
P1836	Torque Converter Clutch Circuit High	20005
P1841	Pressure Control Solenoid 'A' Circuit Low	20000
P1842	Pressure Control Solenoid 'B' Circuit Low	20001
P1843	Pressure Control Solenoid 'C' Circuit Low	20002
P1844	Pressure Control Solenoid 'D' Circuit Low	20003
P1845	Pressure Control Solenoid 'E' Circuit Low	20004
P1846	Torque Converter Clutch Circuit Low	20005
P1861	2-1 Shift	20316
P1862	3-2 Shift	20317
P1863	4-3 Shift	20318
P1864	5-4 Shift	20319
P1865	6-5 Shift	20320
P1871	2-1 Shift Circuit High	20316
P1872	3-2 Shift Circuit High	20317
P1873	4-3 Shift Circuit High	20318
P1874	5-4 Shift Circuit High	20319
P1875	6-5 Shift Circuit High	20320
P1881	1-2 Shift Circuit High	20311
P1882	2-3 Shift Circuit High	20312
P1883	3-4 Shift Circuit High	20313
P1884	4-5 Shift Circuit High	20314
P1885	5-6 Shift Circuit High	20315
P1886	5-6 Shift	20315
P1888	CAN Timeout Instrument Pack during Operation Parking Interlock Emergency Release	20337
P1890	System Voltage	20500
P1891	System Voltage High Input	20500
P1892	System Voltage Low Input	20500
P1893	Supply Voltage Pressure Control Solenoid/Shift Solenoid Circuit High	20501
P1894	Supply Voltage Pressure Control Solenoid/Shift Solenoid Circuit Low	20501
P1895	Supply Voltage Pressure Control Solenoid/Shift Solenoid No Signal	20501
P1896	Supply Voltage Pressure Control Solenoid/Shift Solenoid	20501
P1897	Supply Voltage Sensors High Input	20502
P1898	Supply Voltage Sensors Low Input	20502



## **ZF6HP26**

### **TRANSMISSION FLUID LEAK**

**COMPLAINT:** The transmission appears to be leaking from the front seal (Refer to Figure 1).

**CAUSE:** The vent is routed to the bell-housing in a similar fashion as Ford's 5R55S&W transmissions and could be mistaken as a front seal leak should fluid be pushed out of the vent.

**CORRECTION:** Check the fluid and level to determine if the transmission is either over filled, aerated or overheated. If overfull, correct level. If aerated it could be that it was so overfull that the gear train churned the fluid. Once the correct fluid level has been obtained, if the fluid continues to aerate the pump is sucking in air from either the filter seal, cracked seal neck or the pump is taking in air between the pump halves or from the pump to case surface area. If the fluid has overheated, suspect converter clutch apply issues or a defective converter.

ZF6HP26 TRANSMISSION FLUID LEAK

MISTAKEN FRONT SEAL LEAK

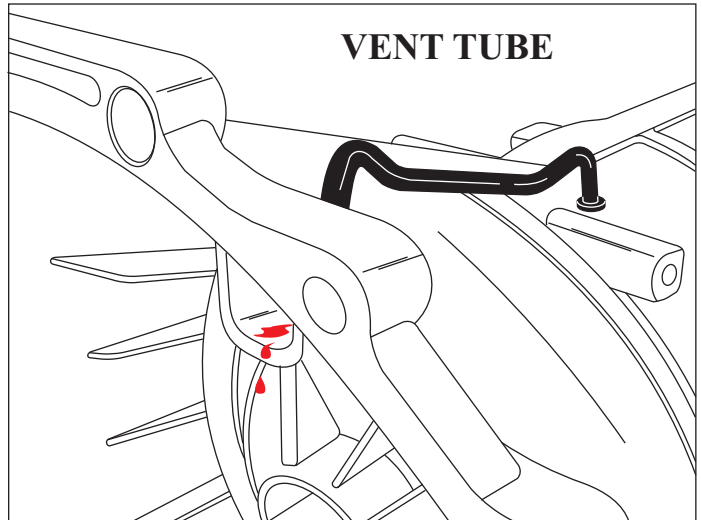
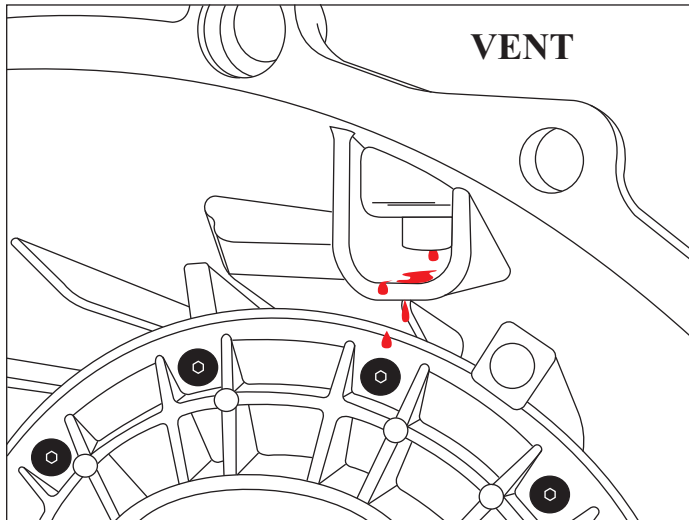
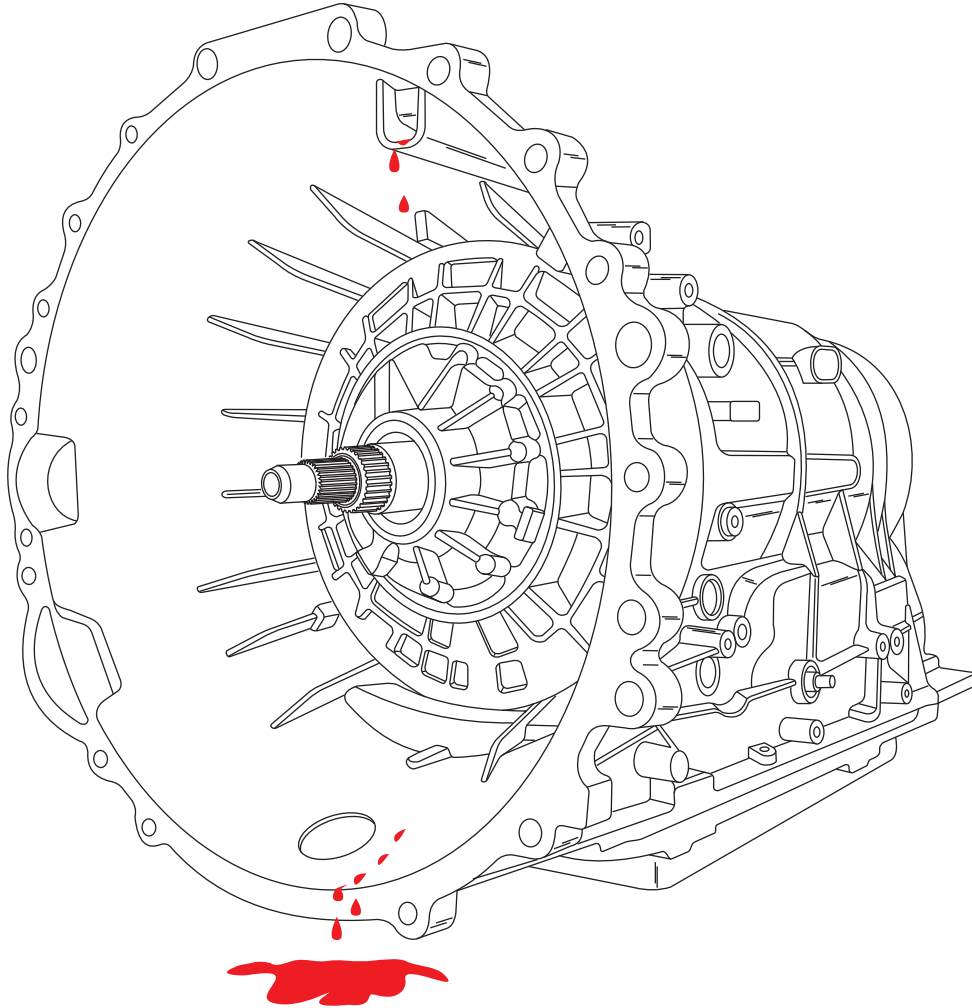

Figure 1

Copyright © 2008 ATSG



ZF6HP26

TRANSMISSION FLUID LEAK

COMPLAINT: The transmission appears to be leaking from the pan gasket, (Refer to Figure 1).

CAUSE: The Mechatronic Sealing Sleeve o-rings (Refer to Figure 2) is leaking and running down along the pan rail giving the appearance that the pan gasket is leaking.

CORRECTION: Replace the Mechatronic Sealing Sleeve.

SERVICE INFORMATION:

- Mechatronic Sealing Sleeve.....ZF Part Number 0501212190*
- Oil Pan/Filter Assembly For Manual Valve Body.....ZF Part Number 0501215789*

ZF6HP26 TRANSMISSION FLUID LEAK

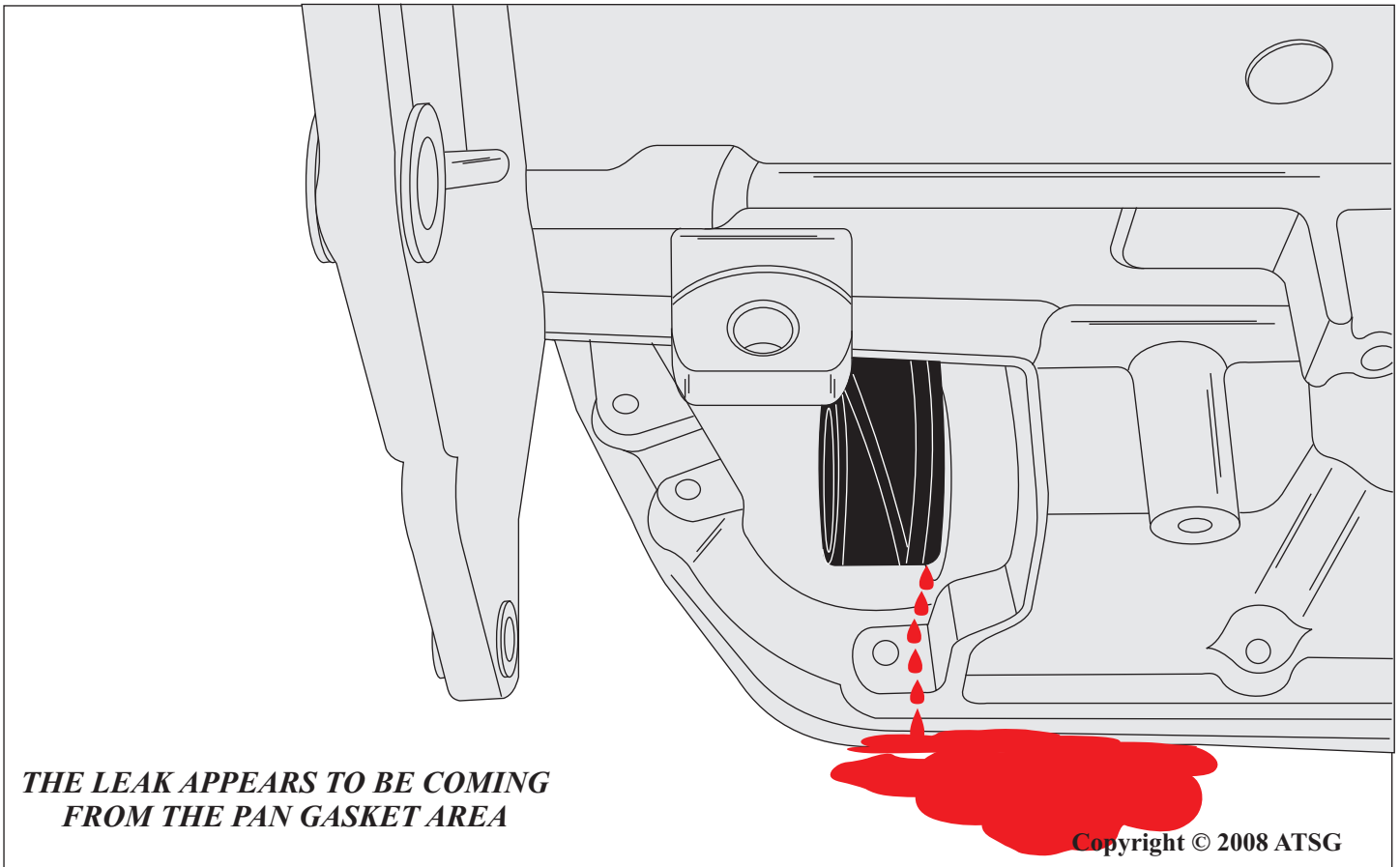

Figure 1

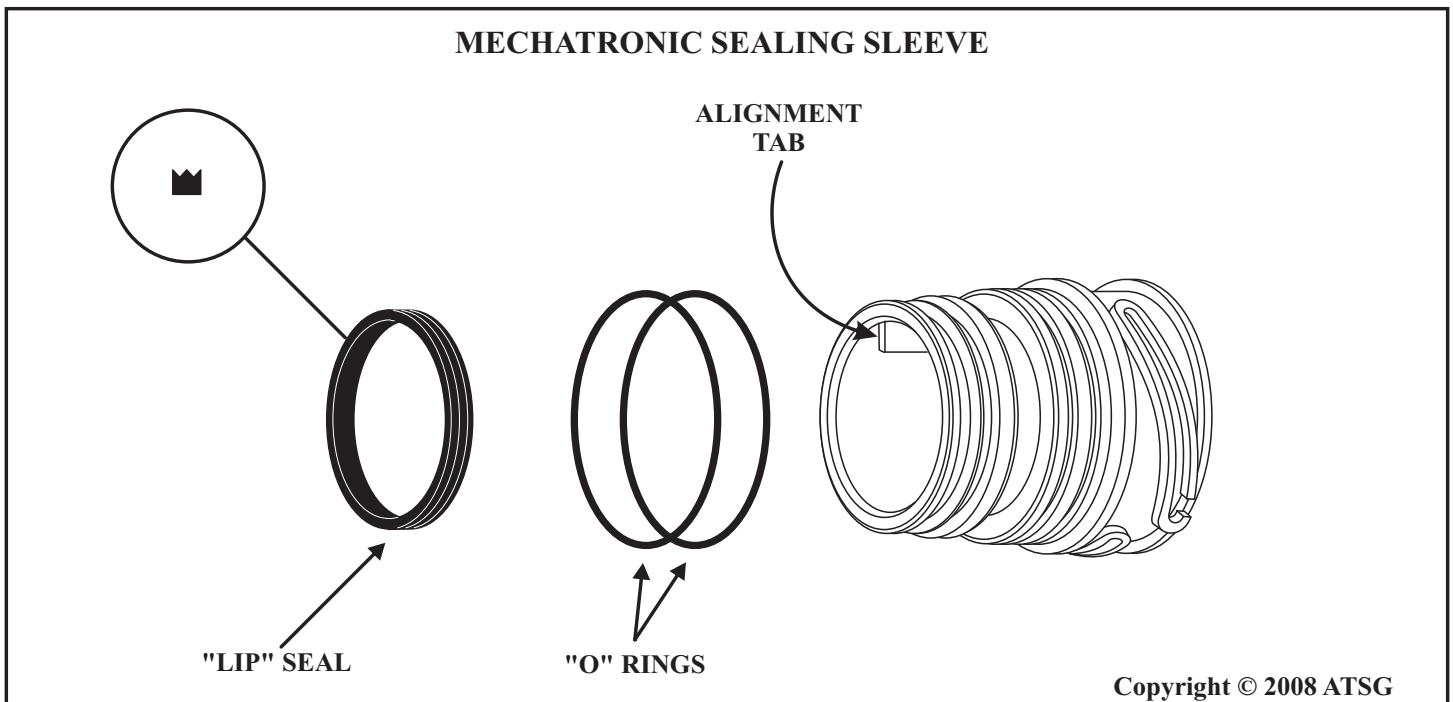

Figure 2



## JAGUAR ZF6HP26

### HARSH KICKDOWN

**COMPLAINT:** Under medium to hard throttle, upshift and kickdown shifts are harsh. This could be intermittent and could be worse when hot.

**CAUSE:** A crack has developed in the intake snorkel to the Mass Airflow Sensor (MAF), See Figure 1, this creates a miscalculation of engine load thereby causing the shift complaints.

**CORRECTION:** Repair or replace the air intake snorkel.

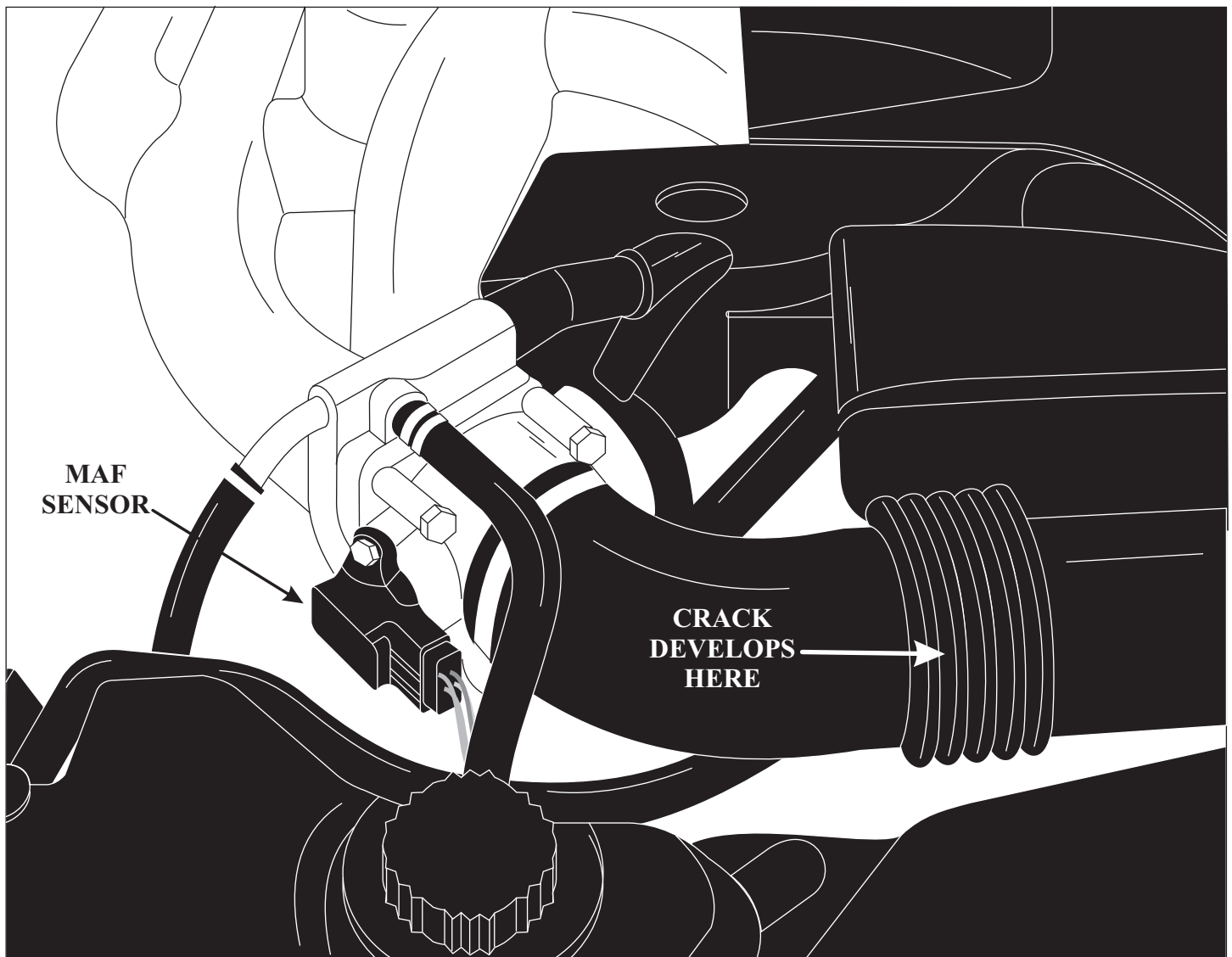

Figure 1

**BMW ZF6HP26**

Page 1 of 2

SI B 25 02 07  
Gear Shift MechanismMay 2008  
Technical Service

This Service Information bulletin supersedes SI B25 02 07 dated **November 2007**.

Similar information may be found in Service Information bulletin [SI B24 19 07](#) dated **May 2008**.

**NEW** designates changes to this revision

**SUBJECT****Diagnostic for GWS Faults - Drive Position "D" Cannot be Engaged****MODEL****NEW** E60, E61 with 6HP19TU or 6HP26TU transmissions

Vehicles produced from 02/25/07 up to 03/09/08

**SITUATION**

The customer complains that after the engine has started or during parking maneuvers, the drive position "D" cannot be engaged using the GWS (Gear Selector Switch).

The DIS/GT1 diagnostic short test finds fault codes ("currently not present") stored in the GWS Gear Selector Switch (A838, A830, A82A) or in the EGS transmission control module (51AB).

None of customer's complaints can be reproduced in the workshop or during test drives.

**CAUSES**

1. The customer is not familiar with GWS operation (incorrect driver usage).
2. In certain cases there may be a possible hardware fault in the GWS shifter.

**CORRECTION**

The following fault codes description provides helpful diagnostic hints when dealing with GWS related complaints on E6X 6HP19TU/6HP26TU equipped vehicles:

- **A838 "Play protection blocking active"**. This fault is set when a lock button is pressed and released numerous times (more than 20 times during a 40 seconds time period with KL15 on). After the fault is set, the locking function does not work – the shifter can be moved forwards and backwards without pressing the unlock button. D or R is not engaged. The transmission stays in Park.
- **A830 "Resetting system faulty"**. This fault is set if the GWS shifter cannot return from the steptronic gate (left position) to the middle position when P is selected. The main reason for this fault is a mechanical blockage. If the shifter is being manually held to the left while the P button is pressed, after five return attempts the A830 fault will be set with the P indicator flashing. Also, this fault may occur under extreme environmental conditions: extremely high or low ambient temperatures; under voltage conditions; or due to incorrect installation (excessive pressure from the shift gate bezel on the shifter disc).

## BMW ZF6HP26

Page 2 of 2

- **A82A "Parking button faulty"**. This fault is set when the P button is pressed very slowly, and/or the button is not fully depressed.
- **51AB "EGS incorrect signal from GWS: P button"**. A fault is stored in the EGS module when the GWS fault code A82A was present (see above). Continue diagnosis in the GWS shifter test plan.

If all four faults are stored, then there is a strong indication that the customer is not fully familiar with the GWS operation strategy. For example: when performing a "three point turn" parking maneuver, the customer needs to move the GWS shifter from the steptronic gate (if driving in the sport or manual mode) to the center position prior to engaging the R or D gears. In such a situation, the customer needs to be advised on the proper operation of the GWS shifter.

**Important Note:**

Please remind the customer that the drive position D or R gear request from the GWS shifter will be ignored (the transmission will stay in Park) if the driver's door is not fully closed and the driver's seat belt is not latched. Also, if the driver were to leave the vehicle with the engine running with drive position D or R selected, the automatic transmission would automatically shift into the park position P.

This is a built-in safety feature of the EGS/GWS, not a system malfunction.

**When diagnosing any GWS related complaint or fault always perform all applicable steps of the DIS/GT1 test plan module B5116\_GWSPER\_E6.**

**NEW** The GWS should only be replaced when prompted by the DIS/GT1 test plans, and after careful evaluation of the all GWS faults stored. After GWS replacement is completed, the vehicle needs to be reprogrammed and recoded, using the current version of Progman (V29.02.00 or higher).

**NEW PARTS INFORMATION**

Part Number	Description	Quantity
61 31 9 174 981	GWS for vehicles with auto transmission (option code S205)	1
61 31 9 174 980	GWS for vehicles with sport auto transmission (option code S2TBA)	1

**WARRANTY INFORMATION**

Covered under the terms of the BMW New Vehicle Limited Warranty.

Please refer to the latest KSD for all applicable labor operations and allowances.

If the appropriate labor operation is not contained in KSD, then a work time labor operation should be used.

**Defect Code** 25 16 08 66 00

## BMW ZF6HP26

Page 1 of 1

SI B 25 01 08  
Gear Shift MechanismJune 2008  
Technical Service**SUBJECT****M5, M6 with SMG III - Gear Selector Display Position Changes from N to R****MODEL**

M5, M6 vehicles with S85 engine and SMG III, produced from 03/07 up to 07/07

**SITUATION**

The customer may complain that when the engine is turned off with the gear selector in position "N", the gear indicator in the instrument cluster intermittently changes to reverse "R" (with transmission gear engagement) for approximately 15 seconds before returning to "N".

Alternately, during the car wash mode with the gear selector in position "N" and the ignition in KL R, the gear selector display spontaneously changes from "N" to "R" (with transmission gear engagement) after approximately 30 seconds.

**CAUSE**

Erroneous signal from the Hall sensors in the SMG gearshift assembly

**CORRECTION**

On a customer complaint basis only, replace the SMGIII gearshift assembly, PN 25 12 2 282 677.

**PARTS INFORMATION**

Part Number	Description	Quantity
25 12 2 282 677	SMG III gearshift assembly	1

**WARRANTY INFORMATION**

Covered under the terms of the BMW New Vehicle Limited Warranty.

**Defect Code:** 25 11 02 13 00

Labor Operation:	Labor Allowance:	Description:
25 12 010*	17 FRU	Replacing SMGIII gearshift assembly

\*Main Work - use this labor operation number when this is the only repair being performed, or if this is the main repair when performed along with other repairs at the same time. If this is not the main repair, refer to KSD for the associated (+) labor operation code.



BMW ZF6HP26

SI B 24 06 08  
Automatic Transmission

October 2008  
Technical Service

SUBJECT

**E70, X5 4.8i with N62TU and 6HP26TU - Various Driveability Complaints**

MODEL

E70, X5 4.8iA produced up to 10/08

SITUATION

The customer may complain about one or a combination of the following situations, listed below:

1. Jolts and jerks when pulling away during a 1-2 upshift.
2. 3-4 shift jolts when switching from acceleration to deceleration during or shortly before the shift.
3. Harsh 2-1 downshift (jolt) when coming to a stop with light brake application.
4. Jolts and/or jerks felt when reaccelerating after coasting.
5. Judder when gently accelerating (most noticeable at an engine speed below 2,000 RPM).

CAUSE

DME and EGS software calibration

SOLUTION

**On a customer complaint basis only**, check the vehicle's integration level.

If the integration level is E070-08-05-525 or lower, then reprogram/recode the complete vehicle with a current Progman version (target integration level is E070-08-09-520, available since the release of Progman V31.1).

WARRANTY INFORMATION

Covered under the terms of the BMW New Vehicle Limited Warranty or the Certified Pre-Owned Program.

**Defect Code:** 24 00 33 98 00

**Labor Operation:**    **Labor Allowance:**    **Description:**

61 00 801                    7 FRU                    Programming coding modules without CAS

61 00 811                    8 FRU                    Programming coding modules including CAS



BMW ZF6HP26

SI B 24 09 08  
Automatic Transmission

October 2008  
Technical Service

**SUBJECT**

**GWS - Transmission Jumps Back to Neutral**

**MODEL**

E70 (X5 3.0i) with N52K and 6HP19TU from 12/06 up to 09/08

E70 (X5 4.8i) with N62TU and 6HP26TU from 12/06 up to 09/08

E60, E61 (528i, 535i) with N52K/N54 and 6HP19TU from 03/07 up to 09/08

E60 (550i) with N62TU and 6HP26TU from 03/07 up to 09/08

**SITUATION**

The customer may complain that intermittently, after selecting the drive or reverse gears, the transmission jumps back to neutral.

Both displays (in the Kombi and on the GWS) are switching from D (or R) to N at the same time.

No faults are stored in either the EGS transmission control module or in the GWS shifter.

**CAUSE**

GWS software error

**SOLUTION**

**On a customer complaint basis only**, check the vehicle's integration level.

If the integration level is:

- On E60, E61 vehicles – E060-08-03-550 or lower
- On E70 vehicles - E070-08-05-525 or lower

Reprogram and recode the complete vehicle with a current Progman version (V31.1, or higher). The target integration levels are E060-08-09-520 or E070-08-09-520, respectively, for E60/E61 and E70 vehicles.

**WARRANTY INFORMATION**

Covered under the terms of the BMW New Vehicle Limited Warranty or the Certified Pre-Owned Program.

**Defect Code:** 25 16 06 66 00

<b>Labor Operation:</b>	<b>Labor Allowance:</b>	<b>Description:</b>
61 00 801	7 FRU	Programming coding modules without CAS



BMW CHASSIS ID

BMW CHASSIS IDENTIFICATION																				
VEHICLE MODEL	1988	1989	1990	1991	1992	1993	1994	1995	1996	1997	1998	1999	2000	2001	2002	2003	2004	2005	2006	2007
318i				E30	E36	E36	E36	E36	E36	E36										
318i Convertible				E30	E30			E36	E36	E36										
318is				E36		E36	E36	E36	E36	E36	E36									
318ti								E36/5	E36/5	E36/5	E36/5	E36/5								
323Ci													E46	E46						
323Ci Convertible													E46	E46						
323i												E46	E46							
323i Convertible											E46	E46								
323is											E46	E46								
325	E30	E30																		
325																		E46	E46	
325																				E90/91
325Ci Convertible															E46	E46				
325Ci															E46	E46				
325i	E30		E30	E30	E36	E36	E36	E36						E46	E46	E46				
325i Convertible	E30	E30	E30	E30	E30	E30	E36	E36												
325i Sport Wagon																				
325is	E30	E30	E30	E30	E36	E36	E36	E36												
325ix	E30																			
325ix AWD	E30	E30	E30	E30																
325xi Sedan														E46	E46	E46				
325xi Sport Wagon														E46	E46	E46				
328																				E90/1/2/3
328Ci													E46							
328i									E36	E36	E36	E46	E46							
328i Convertible									E36	E36	E36	E36								
328is									E36	E36	E36	E36								
330																E46	E46	E46		
330																			E90	
330Ci Convertible														E46	E46	E46				
330Ci Coupe														E46	E46	E46				
330i														E46	E46	E46				
330xi AWD Sedan														E46	E46	E46				



BMW CHASSIS ID

BMW CHASSIS IDENTIFICATION																					
VEHICLE MODEL	1988	1989	1990	1991	1992	1993	1994	1995	1996	1997	1998	1999	2000	2001	2002	2003	2004	2005	2006	2007	
335																	E60	E60	E60	E90/2/3	
525																	E60	E60	E60	E60	
525i																					
525i Sedan																					
525i Sport Wagon																					
525i Touring Wagon																					
528e	E28																				
528i										E39	E39	E39									
528i Sport Wagon												E39	E39								
530																	E60	E60	E60/1	E60/1	
530i							E34	E34													
530i Sedan														E39	E39	E39					
530i Touring Wagon																					
535i	E28	E34	E34	E34	E34																
535is	E28																				
540i							E34	E34													
540i										E39	E39	E39	E39								
540i Sedan														E39	E39	E39					
540i Sport Wagon														E39	E39	E39					
545																	E60	E60			
550																		E60	E60		
635csi	E24	E24																			
645																					
650																					
735i	E32	E32	E32	E32	E32																
735iL																					
740i																					
740iL																					
745i																					
745Li																					
750																					
750iL	E32/2	E32/2	E32/2	E32/2	E32/2	E32/2	E32/2	E38	E38	E38	E38	E38	E38							E63/64	
760i																					E65/66



BMW CHASSIS ID

BMW CHASSIS IDENTIFICATION																						
VEHICLE MODEL	1988	1989	1990	1991	1992	1993	1994	1995	1996	1997	1998	1999	2000	2001	2002	2003	2004	2005	2006	2007		
760Li																E66	E66	E66				
840Ci							E31	E31	E31	E31												
850i				E31	E31																	
850Ci				E31	E31	E31	E31	E31	E31													
850CSi						E31																
L6	E24	E24																				
Alpina B7																				E65		
M Coupe											E36/7	E36/7	E36/7	E36/7	E36/7					E85	E85/86	
M Roadster											E36/7	E36/7	E36/7	E36/7	E36/7							
M3	E30	E30	E30	E30					E36	E36							E46	E46	E46			
M3 Convertible											E36	E36		E46	E46	E46						
M3 Coupe											E36	E36		E46	E46	E46						
M3 Sedan											E36											
M5	E28			E34	E34	E34							E39								E60	E60
M5 Sedan														E39	E39	E39						
M6	E24																				E63	E63/64
X3																						
X5																						
X5 3.0i																						
X5 4.4i																						
X5 4.6iS																						
Z3 Coupe																						
Z3 Coupe 3.0i																						
Z3 Roadster 2.5																						
Z3 Roadster 2.5i																						
Z3 Roadster 3.0i																						
Z3 Roadster 2.8																						
Z4																						
Z4 Roadster																						
Z8 Roadster																						

## AUDI 09E (ZF6HP26)

## Technical Service Bulletin

Chirping, hooting, squeaking noise when shifting between 3-4

37 08 03 2013023/6 May 12, 2008. Supersedes Technical Service Bulletin Group 37 number 08-02 dated January 11, 2008 to revise labor operations.

Model(s)	Year	VIN Range	Vehicle-Specific Equipment
A4	2005	400000 – 999999	09L Transmission
A4	2006	All	
S4 Cabriolet	2005 – 2006	All	
S4	2004 – 2006	All	
A6	2005 – 2006	All	
A8	2004 – 2006	All	09E Transmission

### Condition

- **Noises:** Chirping, hooting, squeaking when shifting up and down 3-4; 4-3.
- **Vibrations:** Shudder during the control phase of the torque converter clutch.

### Technical Background

The torque converter clutch briefly generates (about 500 ms) noises or vibrations/shuddering when changing gears.

Note: This only applies to vibrations/shuddering during the *control phase* of the converter control/converter close. This converter condition can be checked in MVB 007/3 (converter open/converter control closed).

### Production Solution

Optimized ATF (blue) from gearbox numbers 4000597 and 95253.

### Service

It is not necessary to receive an authorization number from the Technical Assistance Center for the repairs described in this bulletin.

1. If you encounter a vehicle with a tuned ECM or TCM, your dealership must do the following before performing any procedure that updates ECM or TCM programming:



**Note:**

Any Update Programming procedure (flash) may overwrite any tuned ECM or TCM programming. A *tuned* ECM or TCM is described as any ECM or TCM altered so as to perform outside the normal parameters and specifications approved by Audi of America, Inc.



JAGUAR ZF6HP26)

JAGUAR

MODEL  
S-TYPE, XJ

DATE  
26 SEP 2008

NUMBER  
JTB00125  
(Issue 1)

Service

TECHNICAL BULLETIN

SECTION: 307

**Transmission MIL Illumination with DTC P1794 Stored - Repair Procedure**

AFFECTED VEHICLE RANGE:

S-TYPE (X200)

VIN: N52048 - N90324  
Model Year: 2006 - 2008

XJ (X350)

VIN: G49701 - Onwards  
Model Year: 2006 - Onwards

CONDITION SUMMARY:

**Situation:** The Transmission Malfunction Indicator Lamp (MIL) may be illuminated with Diagnostic Trouble Code (DTC) P1794 stored and the transmission may be in default mode. This may be caused by the Transmission Control Module (TCM) maximum voltage being exceeded during wide open throttle periods.

**Action:** In the event of a customer concern of the above, refer to the Repair Procedure outlined below to reconfigure the TCM and carry out an adaption drive cycle.

PARTS:

No parts necessary

TOOLS:

IDS with latest IDS DVD; software first available on IDS DVD114 Patch File 7  
Midtronics PSC-550 Vehicle Power Supply

WARRANTY:

**NOTE:** Repair procedures are under constant review, and therefore times are subject to change; those quoted here must be taken as guidance only. Always refer to DDW to obtain the latest repair time.

DDW requires the use of causal part numbers. Labor only claims must show the causal part number with a quantity of zero.

Description	SRO	Time (hours)	Condition Code	Causal Part
Reconfigure the TCM and carry out adaption drive cycle	86.99.14	1.10	42	C2C 29833

Normal warranty policy and procedures apply.

NOTE: The information in Technical Bulletins is intended for use by trained, professional Technicians with the knowledge, tools, and equipment required to do the job properly and safely. It informs these Technicians of conditions that may occur on some vehicles, or provides information that could assist in proper vehicle service. The procedures should not be performed by 'do-it-yourselfers'. If you are not a Dealer, do not assume that a condition described affects your vehicle. Contact an authorized Jaguar service facility to determine whether this bulletin applies to a specific vehicle.

**JAGUAR ZF6HP26)**

JAGUAR

**TECHNICAL BULLETIN**

NUMBER

**JTB00125**

(Issue 1)

**REPAIR PROCEDURE:****RECONFIGURE THE TRANSMISSION CONTROL MODULE****CAUTION: TCM reconfiguration must be carried out as described in the Repair Procedure:**

- Clear adaptations
- Reconfigure TCM
- Carry out adaption drive cycle

1. Ensure the ignition is 'off', parking brake is 'applied', and the transmission is in 'Park'.

**CAUTION: A Midtronics PSC-550 Vehicle Power Supply must be connected to the vehicle battery during diagnosis / module programming.**

2. Connect the Midtronics PSC-550 Vehicle Power Supply to the vehicle battery.

**NOTE: IDS must be loaded with software release DVD114 Patch File 7 or later.**

3. Connect the IDS to the vehicle and begin a new diagnostic session by entering the correct VIN for the current vehicle.
4. Follow the IDS prompts to read the vehicle configuration.
5. Select 'Yes' when prompted 'Do you wish to read diagnostic trouble codes?'
6. Select 'tick' to continue.
7. Clear all diagnostic trouble codes.
8. Select the 'Vehicle Configuration' tab when Content Model is displayed.
9. From the Vehicle Configuration menu, select 'Special applications'.
10. Select 'Transmission control module adaption clear' from the Special applications menu.
11. Follow all on-screen instructions to complete this task.
12. Select 'Configure existing module' from the Vehicle Configuration menu.
13. Configure the 'Transmission control module' by selecting from the drop-down menu:
  - 'Module programming' > 'Configure existing module' > 'Transmission control module'
14. Select 'tick' to continue, following all on-screen instructions to complete this task.
  - IDS will return to the Vehicle Configuration menu when completed.
15. Exit the current session.
16. Disconnect IDS and the Midtronics PSC-550 Vehicle Power Supply from the vehicle.

## JAGUAR ZF6HP26)

JAGUAR

## TECHNICAL BULLETIN

NUMBER  
JTB00125  
(Issue 1)

## CARRY OUT ADAPTION DRIVE CYCLE

△ NOTE: The vehicle may be driven normally to a suitable flat road before carrying out the adaption drive cycle road test.

△ NOTE: The adaption drive cycle must be carried out with the transmission in 'normal' mode on a flat road. Transmission fluid temperature must be above 60°C (140°F) and below 100°C (212°F).

1. Accelerate gently from rest using steady light throttle:
  - The 1-2, 2-3, and 3-4 upshifts **must** take place between 1,800 - 2,000 rpm (S-TYPE 3.0L) and 1,450 - 1,600 rpm (S-TYPE and XJ 4.2L).
2. Continue to gently accelerate to **50 mph (80 Kph)**, ensuring the transmission shifts into fifth gear.
3. Release the throttle, allowing the vehicle to slow down and the transmission to downshift into fourth gear.
4. Once the transmission has shifted into fourth gear, brake gently to a stop.
5. Hold vehicle stationary for 15 seconds.
6. Repeat steps 1 - 5 an additional four times.



JAGUAR ZF6HP26)

JAGUAR

Service

MODEL  
S-TYPE,  
XJ, XK

DATE  
03 FEB 2009

NUMBER  
JTB00145  
(Issue 1)

TECHNICAL BULLETIN

SECTION: 307

ZF Transmission Adaptions Drive Cycle - IDS Procedure

AFFECTED VEHICLE RANGE:

S-TYPE (X200)

VIN: M45255 - N91220  
Model Year: 2003- 2008

XJ (X350)

VIN: G00001 - Onwards  
Model Year: 2004 - Onwards

XK (X100)

VIN: A30645 - A48684  
Model Year: 2003 - 2006

CONDITION SUMMARY:

**Situation:** The Integrated Diagnostic System (IDS) now contains a process to 'adapt' the transmission clutch pressures after they have been cleared for ZF transmissions fitted to vehicles listed in the Affected Vehicle Range above.

**Action:** In the event it becomes necessary to perform a transmission adaptions drive cycle (for example: after a customer complaint of harsh shifting following transmission control module reconfiguration), refer to the IDS Procedure outlined below.

PARTS:

No parts necessary, information only

TOOLS:

Latest IDS DVD; software first available on IDS DVD116 Patch File 2

WARRANTY:



**NOTE:** Repair procedures are under constant review, and therefore times are subject to change; those quoted here must be taken as guidance only. Always refer to DDW to obtain the latest repair time.

DDW requires the use of causal part numbers. Labor only claims must show the causal part number with a quantity of zero.

Description	SRO	Time (hours)	Condition Code	Causal Part
ZF Transmission Adaption Drive Cycle using IDS (Includes time for two people to carry-out the adaption drive cycle)	86.99.77	0.80	42	C2C33532

Normal warranty policy and procedures apply.

NOTE: The information in Technical Bulletins is intended for use by trained, professional Technicians with the knowledge, tools, and equipment required to do the job properly and safely. It informs these Technicians of conditions that may occur on some vehicles, or provides information that could assist in proper vehicle service. The procedures should not be performed by 'do-it-yourselfers'. If you are not a Dealer, do not assume that a condition described affects your vehicle. Contact an authorized Jaguar service facility to determine whether this bulletin applies to a specific vehicle.

## JAGUAR ZF6HP26)

JAGUAR

## TECHNICAL BULLETIN

NUMBER

JTB00145

(Issue 1)

**IDS PROCEDURE****PERFORM TRANSMISSION ADAPTION DRIVE CYCLE**

**CAUTION:** Ensure the ignition is switched 'OFF', parking brake is 'ON', and the transmission selector lever is in park.



**NOTE:** IDS must be loaded with software release DVD116 Patch File 2 or later.

1. Connect the IDS to the vehicle and begin a new diagnostic session by entering the correct VIN for the current vehicle.
2. Follow the IDS prompts to read the vehicle configuration.
3. Select 'No' when prompted 'Do you wish to read diagnostic trouble codes?'
4. Select 'tick' to continue.
5. Select the 'Vehicle Configuration' tab when Content Model is displayed.
6. Select 'Special Applications'.
7. Select 'Transmission Control Module Adaption'.



**CAUTION:** On-road testing *must* be performed as a two-man operation.



**CAUTION:** Do not move the accelerator pedal during gear shifts. Follow all on-screen instructions and note all warnings.



**NOTE:** The car may be driven as normal to a suitable flat road before carrying out the drive cycle road test. The clutches may be adapted in any order; it is not necessary to carry out the adaptations in the order shown on the IDS screen. The process below gives the ideal adaption drive cycle; however, if road conditions do not permit the drive cycle to be completed the car may be driven normally until suitable conditions are found, then the drive cycle can be continued.



**NOTE:** This process must be carried-out with the transmission in 'normal' mode (*not* sports mode) on a flat road. The transmission fluid temperature must be above 50°C (122°F) and below 100°C (212°F). If the maximum temperature is reached, drive vehicle at a constant speed to cool the transmission.

8. 'C' Clutch (1-2 upshift)
  - Using light throttle, accelerate from rest, ensuring the torque band is within the indicated bar graph range.
  - Once the 1-2 upshift is completed and the correct torque conditions have been met, the next vacant box adjoining 'C' clutch will turn green with a 'tick' to show 'C' clutch has adapted. The highlight will move to 'B' Clutch.
9. 'B' Clutch (2-3 upshift)
  - Maintaining constant throttle input and the torque band is within the indicated bar graph range, continue accelerating.
  - Once the 2-3 upshift is completed and the correct torque conditions have been met, the next vacant box adjoining 'B' clutch will turn green with a 'tick' to show 'B' clutch has adapted. The highlight will move to 'E' Clutch.
10. 'E' Clutch (3-4 upshift)
  - Maintaining constant throttle input and the torque band is within the indicated bar graph range, continue accelerating.
  - Once the 3-4 upshift is completed and the correct torque conditions have been met, the next vacant box adjoining 'E' clutch will turn green with a 'tick' to show 'E' clutch has adapted. The highlight will move to 'A' clutch.



JAGUAR ZF6HP26)

JAGUAR

TECHNICAL BULLETIN

NUMBER  
JTB00145  
(Issue 1)

11. 'A' Clutch

- Maintaining constant throttle input and the torque band is within the indicated bar graph range, continue accelerating to 50 mph (80kph), ensuring the transmission upshifts into fifth gear.
- Lift off the throttle, allowing the vehicle to slow down until fourth gear engages. The next vacant box for 'A' clutch will turn green with a 'tick'.

12. 'D' Clutch

- Gently braking from fourth gear to a standstill and holding for 10 seconds will alternately populate one of the clutches ('A' on the first standstill and 'D' on the next standstill, etc).

13. Once each clutch has adapted three times as shown by the green 'ticks' in the boxes, the 'Status – Adaption Complete' box will turn green with a 'tick' and the transmission adaption drive cycle operation is complete.

14. When the task is complete, exit the current session.

15. Disconnect IDS.





LAND ROVER ZF6HP26)

TECHNICAL BULLETIN

No: LTB00172  
Issue: 1  
Date: 15 Sept 2008

CIRCULATE TO:	Service Mgr	Warranty	Workshop	Body Shop	Parts
	X	X	X		X

SECTION: 307

Transmission Input Shaft Seal - Lower Level Service Part Availability and Repair Procedure

AFFECTED VEHICLE RANGE:

LR3 (LA)	VIN:	5A000360 - Onwards
	Model Year:	2005 - Onwards
Range Rover (LM)	VIN:	6A194480 - Onwards
	Model Year:	2006 - Onwards
Range Rover Sport (LS)	VIN:	6A900129 - Onwards
	Model Year:	2006 - Onwards

CONDITION SUMMARY:

Situation: A transmission input shaft seal is now available as a serviceable part. It is no longer necessary to replace the complete transmission for concerns related to the input shaft seal.

Action: In the event of transmission input shaft seal replacement, refer to the Repair Procedure outlined below.

PARTS:

TZB500030 .....Input shaft seal Qty: 1

TOOLS:

Refer to Workshop Manual (GTR) for any required special tools

WARRANTY:

NOTE: Repair procedures are under constant review, and therefore times are subject to change; those quoted here must be taken as guidance only. Always refer to DDW to obtain the latest repair time.

DDW requires the use of causal part numbers. Labor only claims must show the causal part number with a quantity of zero.

Description	SRO	Time (hours)	Condition Code	Causal Part
Input shaft seal - Renew - LR3 4.0L V6	44.20.17	6.70		TZB500030
Input shaft seal - Renew - LR3 4.4L V8		6.90		
Input shaft seal - Renew - Range Rover		5.60		
Input shaft seal - Renew - Range Rover Sport		7.20		

Normal warranty policy and procedures apply.

NOTE: The information in Technical Bulletins is intended for use by trained, professional Technicians with the knowledge, tools, and equipment required to do the job properly and safely. It informs these Technicians of conditions that may occur on some vehicles, or provides information that could assist in proper vehicle service. The procedures should not be performed by 'do-it-yourselfers'. If you are not a Retailer, do not assume that a condition described affects your vehicle. Contact an authorized Land Rover service facility to determine whether this bulletin applies to a specific vehicle.