

TECHNICAL BULLETIN

LTB00420NAS2
16 NOV 2012



ISSUE '2' CHANGES ARE EXTENSIVE AND THEREFORE NOT HIGHLIGHTED

SECTION: 204-05

Air Suspension Compressor Replacement

AFFECTED VEHICLE RANGE:

LR3 (LA)	VIN: 5A000360 - 9A513325 Model Year: 2005 - 2009
LR4 (LA)	VIN: AA510742 - CA638964 Model Year: 2010 - 2012
Range Rover Sport (LS)	VIN: 6A900129 - 7A999999; 7A100000 - BA299999; BA700000 - DA768550 Model Year: 2006 - 2013

CONDITION SUMMARY:

△ **NOTE: Two different types of air suspension compressors have been used - Hitachi and 'old-design' AMK - as per the VIN ranges below:**

- **Hitachi:**
 - **LR3: 5A000360 - 9A513325**
 - **Range Rover Sport: 6A900129 - 7A999999; 7A100000 - 9A215622**
- **'Old-design' AMK**
 - **LR4: AA510742 - CA638964**
 - **Range Rover Sport: AA212147 - DA768550**

Situation: The Air suspension warning lamp may be illuminated, the air suspension may fail to raise the vehicle, and Diagnostic Trouble Code (DTC) C1A20-64 may be stored. Vehicles within the above VIN ranges have been fitted with either a Hitachi or 'old-design' AMK air suspension compressor.

△ **NOTE: A limited number of vehicles may have been previously repaired with an 'old-design' AMK compressor.**

Cause: This may be caused by a faulty air suspension compressor.

Action: In the event of a customer concern where a Hitachi air suspension compressor must be replaced, refer to the Repair Procedure outlined below.

PARTS:

LR044360..... AMK air compressor replacement kit Qty: 1

TOOLS:

IDS with latest IDS-DVD and Calibration File; first available on DVD131.07 v.118
Land Rover-approved Midtronics Vehicle Power Supply
Refer to Workshop Manual for any required special tools

WARRANTY:

△ **NOTE: Repair procedures are under constant review, and therefore times are subject to change; those quoted here must be taken as guidance only. Always refer to DDW to obtain the latest repair time.**

DDW requires the use of causal part numbers. Labor only claims must show the causal part number with a quantity of zero.

NOTE: The information in Technical Bulletins is intended for use by trained, professional Technicians with the knowledge, tools, and equipment required to do the job properly and safely. It informs these Technicians of conditions that may occur on some vehicles, or provides information that could assist in proper vehicle service. The procedures should not be performed by 'do-it-yourselfers'. If you are not a Retailer, do not assume that a condition described affects your vehicle. Contact an authorized Land Rover service facility to determine whether this bulletin applies to a specific vehicle.

DESCRIPTION	SRO	TIME (HOURS)	CONDITION CODE	CAUSAL PART
Air suspension compressor – replace Hitachi with AMK	60.50.89/58	0.60	42	LR023964 (Hitachi) LR032902 (AMK)

Normal Warranty policies and procedures apply

REPAIR PROCEDURE

△ **NOTE:** Some variation in the illustrations may occur, but the essential information is always correct.

1. △ **NOTE:** Hitachi compressor (①).

△ **NOTE:** Old-design AMK air suspension compressor (②).

△ **NOTE:** New-design AMK air suspension compressor (③).

△ **NOTE:** Note that there is a subtle difference between the two AMK air suspension compressors.

Identify the air suspension compressor installed on the vehicle.

- a. If a Hitachi air suspension compressor (①) is installed, carry out steps 2 to 19 and 38 to 49.
- b. If an old-design AMK air suspension compressor (②) is installed, carry out steps 20 to 49.

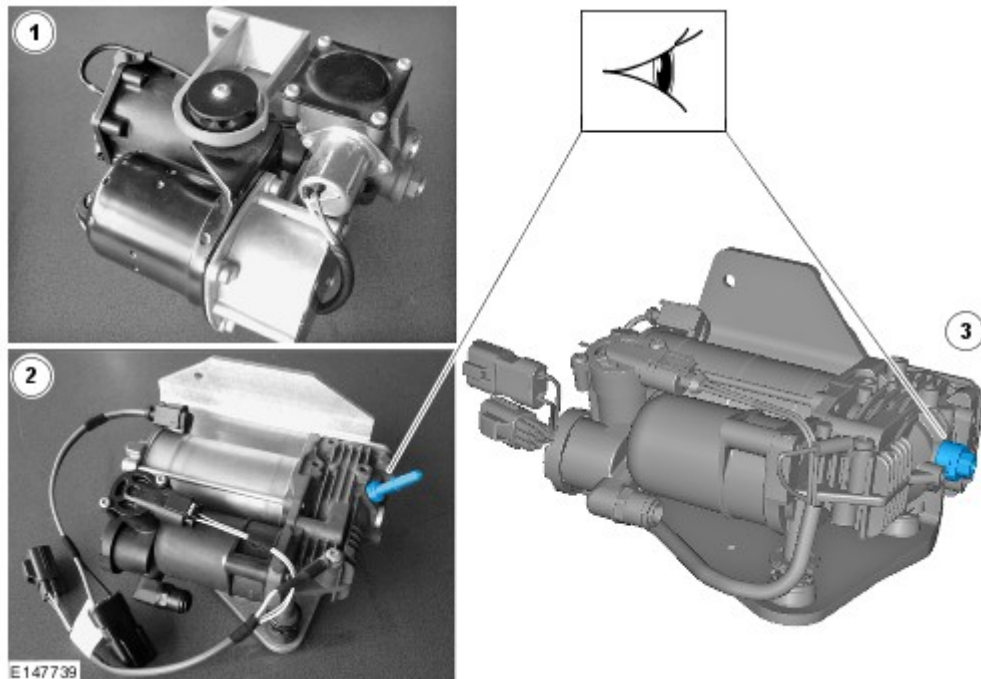

△ **NOTE:** STEPS 2-19 FOR VEHICLES EQUIPPED WITH HITACHI AIR SUSPENSION COMPRESSOR ONLY.

2. ⚠ **WARNING:** Steps 2 and 3 must be carried out within 10 minutes of each other; failure to follow this instruction may result in personnel injury.

⚠ **CAUTION:** Make sure the ignition switch is turned 'OFF', the park brake is 'ON', and the transmission gear selector lever is in 'P' (Park) position.

Open the front door.

3. **⚠ WARNING: Do not work on or under a vehicle supported only by a jack. Always support the vehicle on safety stands.**

- ⚠ WARNING: Make sure that at least one wheel is off the ground.**

Refer to Workshop Manual section 100-02 and raise and support the vehicle; make sure at least one of the wheels is off the ground.

4. Remove the air suspension compressor lower cover.

- Remove the three (3) bolts.
- Release the five (5) clips.

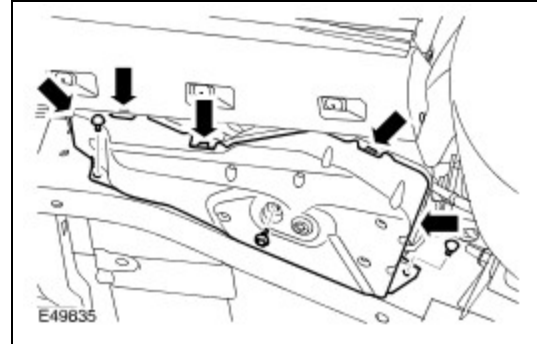

5. **⚠ CAUTION: Make sure that the 3 air suspension compressor mounting nuts in the chassis rail are not damaged or corroded. If required, replace the nuts.**

- ⚠ CAUTION: Always plug any open connections to prevent contamination.**

- △ NOTE: Access to the top compressor fixing bolt is very restricted. It is advisable to use a 3/8-inch-drive socket with a flexible coupling.**

Remove the air suspension compressor.

- Disconnect the three (3) air lines.
- Disconnect the two (2) electrical connectors.
- Remove the three (3) bolts.

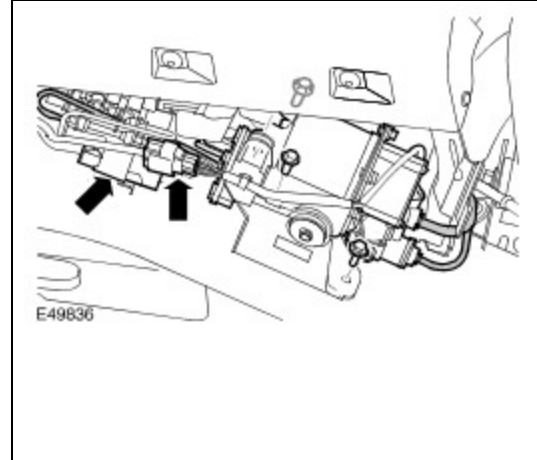

6. Remove and discard the old air suspension compressor upper cover.

7. **⚠ CAUTION: Make sure that the cover is correctly located behind the bracket as shown; failure to follow this instruction may cause noise/vibration issues.**

Install the new air suspension compressor upper cover.

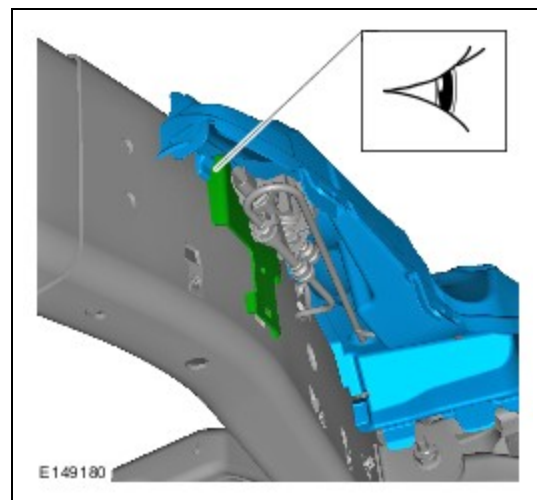

8. **⚠ CAUTION: Make sure the new pipe is fitted securely into the new air suspension compressor connector; failure to follow this instruction may cause damage to the component.**

△ NOTE: Old-design AMK air suspension compressor shown; new-design AMK air suspension similar.

Install the new exhaust pipe to the new air suspension compressor as shown.

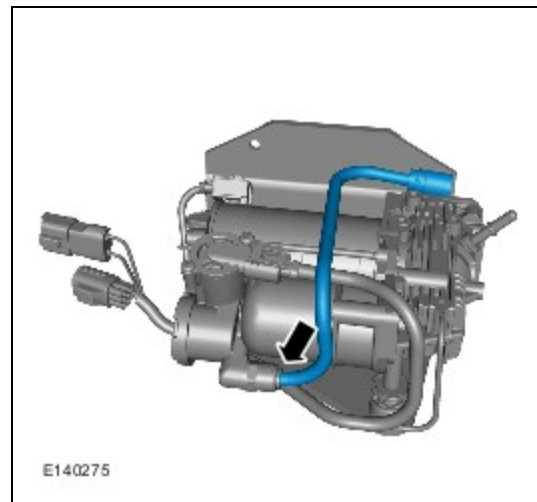

9. **△ NOTE: The pipe to be cut is the smaller diameter pipe.**

Using a suitable pipe cutter tool, cut the air suspension feed pipe in the position indicated.

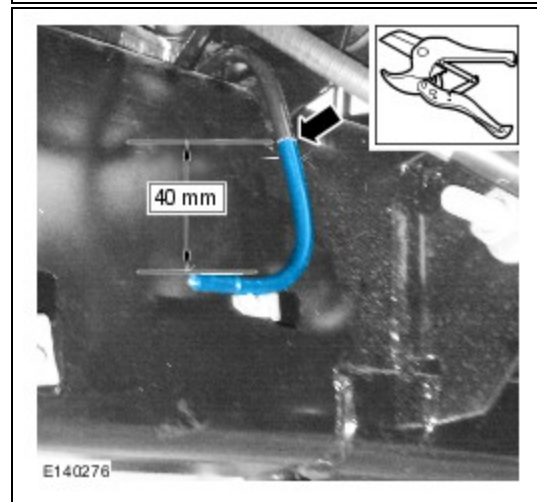

10. **⚠ CAUTION: Make sure the air line insert is in the correct orientation; failure to follow this instruction may cause damage to the component.**

Install the air line insert until there is no part of the air line insert showing, and it is flush with the end of the air line.

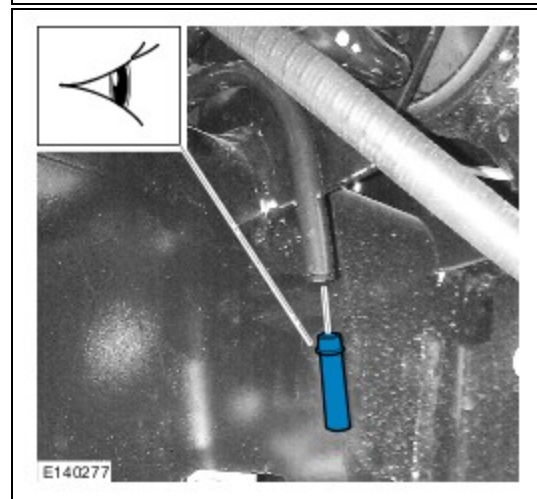

11. Remove and discard the air line and connector from the valve block.

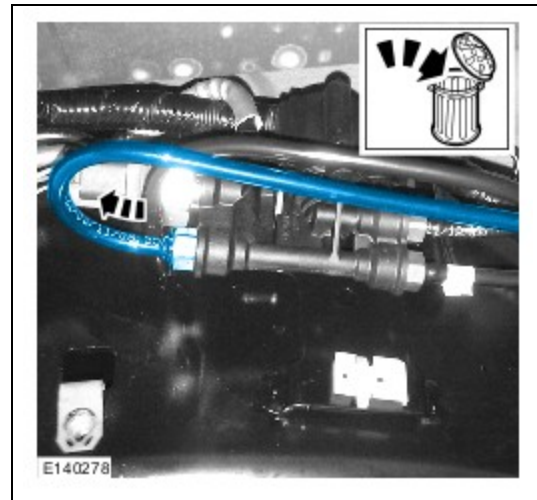

12. **⚠ CAUTION: Do not remove the blanking plug until after the connector is tightened.**

Install new connector and tighten to 2Nm.

- Remove blanking plug.

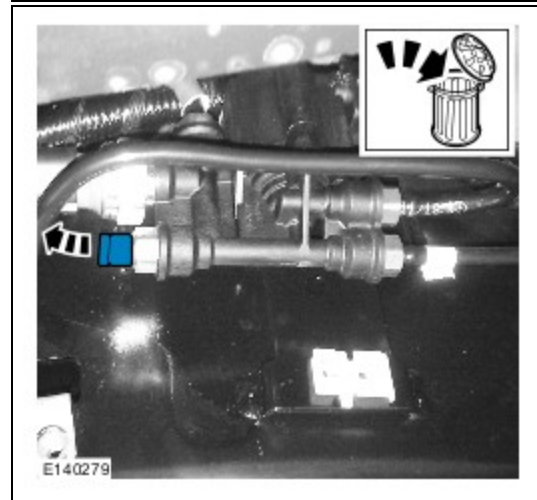

13. **⚠ CAUTION: Make sure the air line link pipe is correctly fitted. It must be inserted to a depth of 20mm.**

⚠ CAUTION: Make sure the air lines and wiring are not trapped between the Air Compressor mounting bracket and the chassis; failure to follow this instruction may cause damage to the vehicle.

Position the new air suspension compressor using the new mounting bolts (do not tighten the bolts fully) and install the new air line link pipe.



14. Connect the new air line link pipe.



15. Install the new air line link pipe.

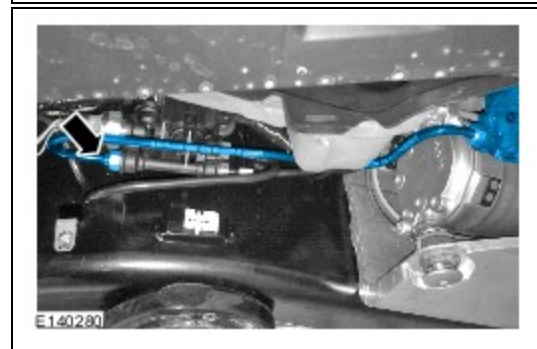



16. **⚠ CAUTION: Make sure the air lines and wiring are not trapped between the air suspension compressor mounting bracket and the chassis; failure to follow this instruction may cause damage to the vehicle.**

△ NOTE: Make sure that the air suspension compressor upper cover is installed correctly.

Secure the air suspension compressor and bracket assembly.

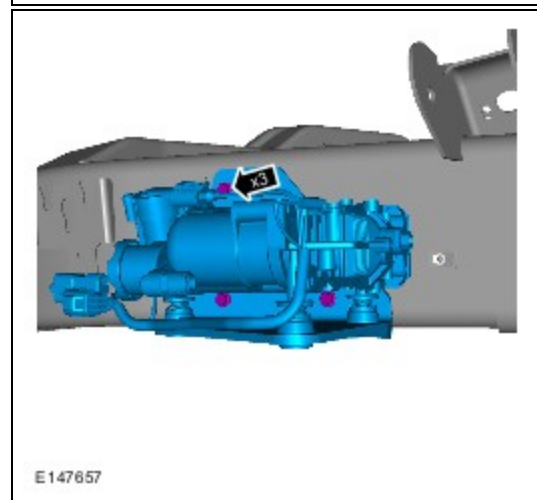
- Tighten the three (3) bolts to 23 Nm.



17.  **NOTE: Air suspension compressor upper cover shown removed for clarity.**

Connect the air line.



18. Connect the air line and two (2) electrical connectors.

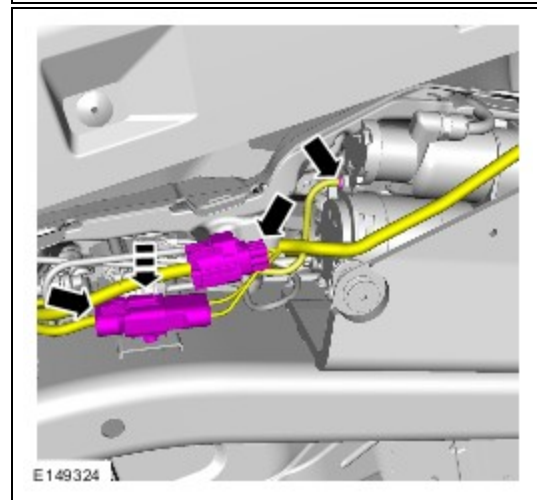

19. Install the air suspension compressor lower cover.

- Secure the five (5) clips.
- Tighten the three (3) bolts to 9 Nm.

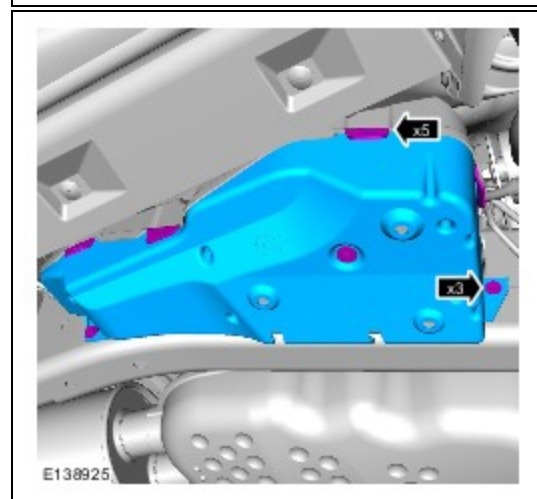

△ **NOTE: STEPS 20-37 FOR VEHICLES EQUIPPED WITH OLD-DESIGN AMK AIR SUSPENSION COMPRESSOR ONLY.**

20. **⚠ WARNING: Do not work on or under a vehicle supported only by a jack. Always support the vehicle on safety stands.**

⚠ WARNING: Make sure that at least one wheel is off the ground.

Refer to Workshop Manual section 100-02 and raise and support the vehicle; make sure at least one of the wheels is off the ground.

21. Remove the air suspension compressor lower cover.

- Remove the three (3) bolts.
- Release the five (5) clips.

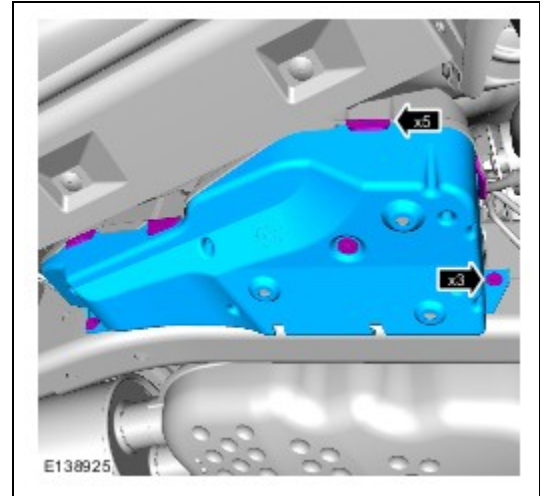

22. Disconnect the two (2) air lines.

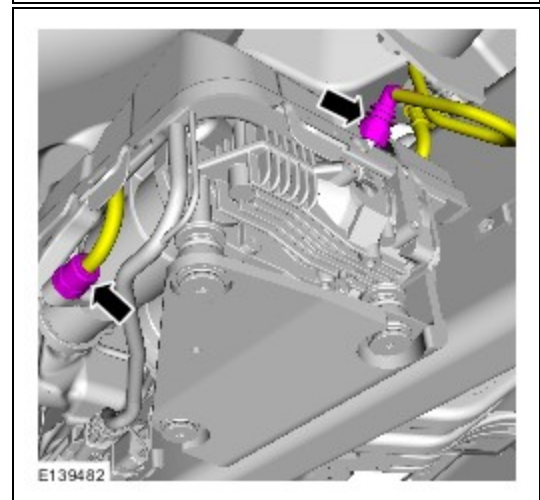

23. If installed, remove and discard the air line link pipe.

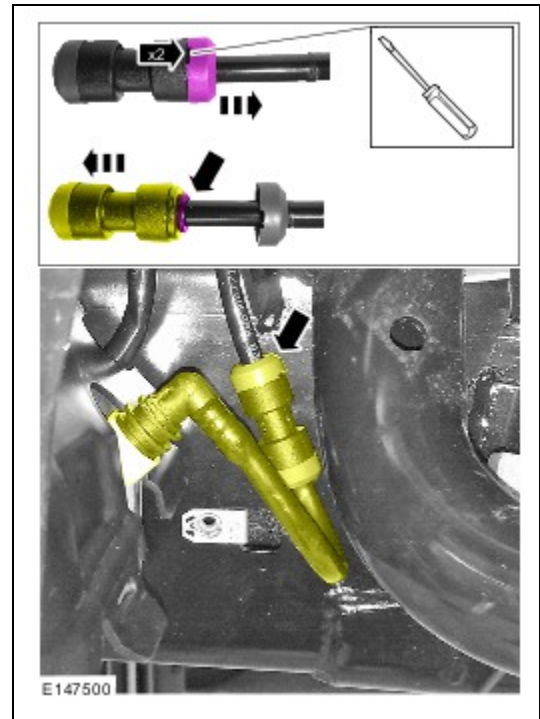

24. Disconnect the air line and two (2) electrical connectors.

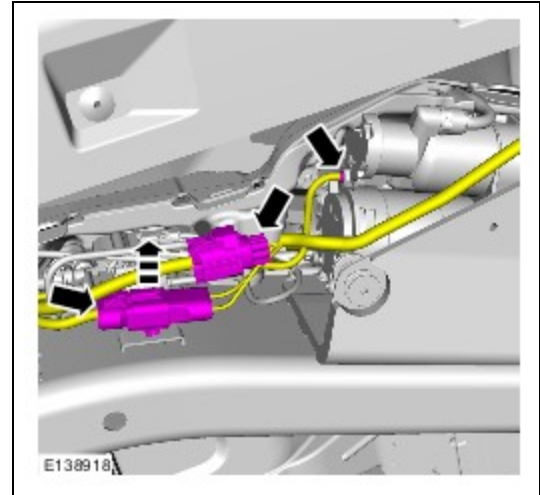

25. **⚠ CAUTION: Make sure that the three (3) air suspension compressor mounting nuts in the chassis rail are not damaged or corroded. If required, replace the nuts.**

△ NOTE: New-design AMK air suspension compressor shown, old-design AMK air suspension similar.

Remove the air suspension compressor and bracket assembly.

- Remove the three (3) bolts.

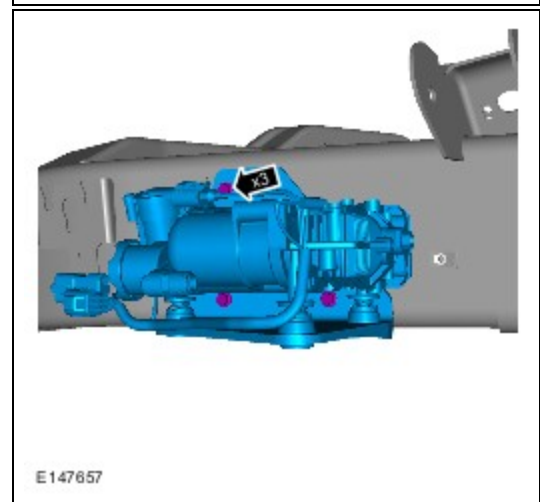

26. Remove and discard the old air suspension compressor upper cover.

27. **⚠ CAUTION:** Make sure that the cover is correctly located behind the bracket as shown; failure to follow this instruction may cause noise/vibration issues.

Install the new air suspension compressor upper cover.

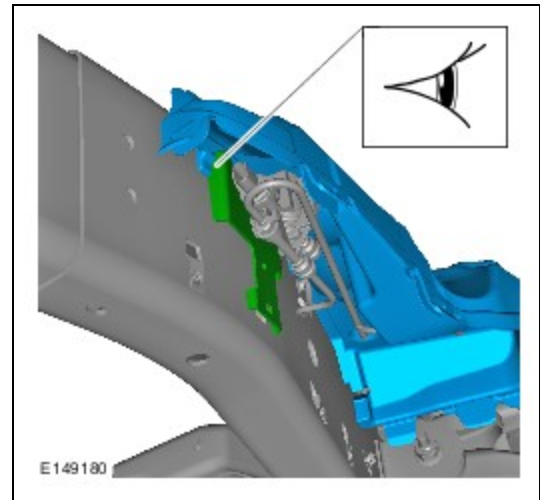

28. **⚠ CAUTION:** Make sure the air lines and wiring are not trapped between the air suspension compressor mounting bracket and the chassis; failure to follow this instruction may cause damage to the vehicle.

△ NOTE: Make sure that the air suspension compressor upper cover is installed correctly.

Install the air suspension compressor and bracket assembly.

- Tighten the three (3) bolts to 23 Nm.

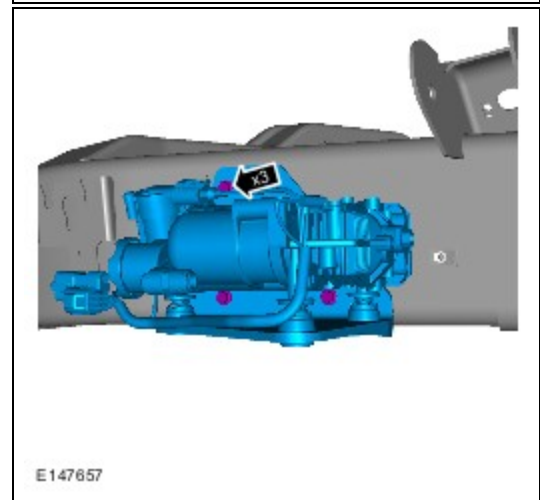

29. **△ NOTE:** Old-design AMK compressor shown; new-design AMK air compressor similar.

△ NOTE: Component shown removed from vehicle for clarity.

Connect the air line.

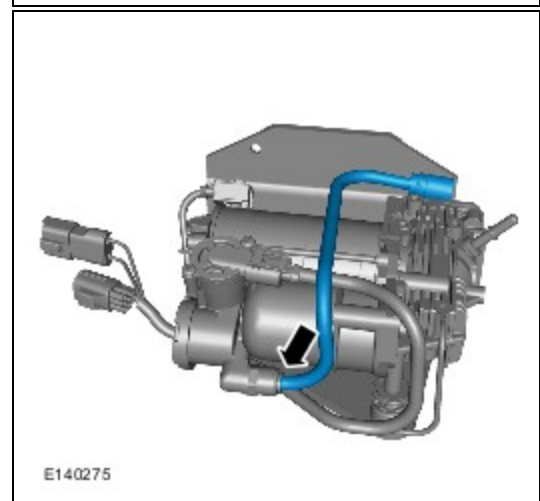

△ **NOTE: STEPS 30-31 FOR VEHICLES WITH AIR LINK PIPE ONLY.**

30. ⚠ **CAUTION: Make sure the air line link pipe is correctly fitted. It must be inserted to a depth of 20mm.**

Install the new air line link pipe.



31. Connect the new air line link pipe.



△ **NOTE: STEPS 32-34 FOR VEHICLES WITHOUT AIR LINK PIPE ONLY.**

32. Using a suitable pipe cutter tool, cut the air suspension feed pipe in the position indicated.

- Discard the lower section of the pipe.

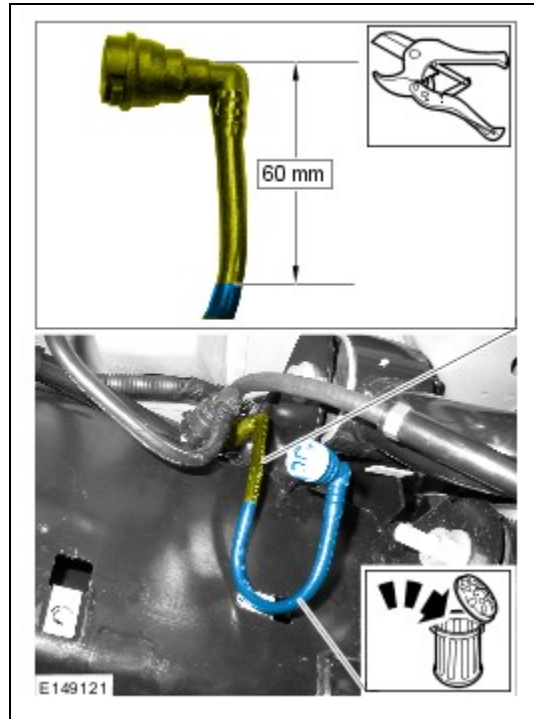

33. ⚠ **CAUTION: Make sure the air line insert is in the correct orientation; failure to follow this instruction may cause damage to the component.**

Install the air line insert until there is no part of the air line insert showing, and it is flush with the end of the air line.

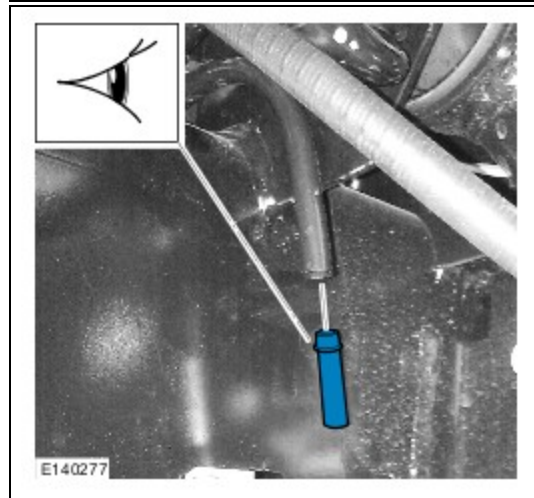

34. Install the new air line link pipe.



△ **NOTE: ALL VEHICLES.**

35. Connect the air line and two (2) electrical connectors.

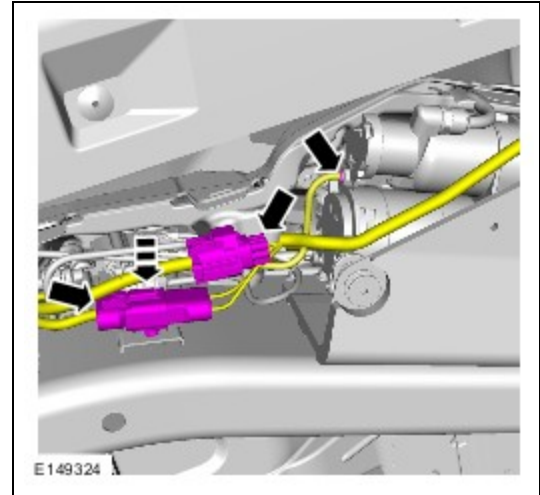

36. △ **NOTE: Air suspension compressor upper cover shown removed for clarity.**

Connect the air line.

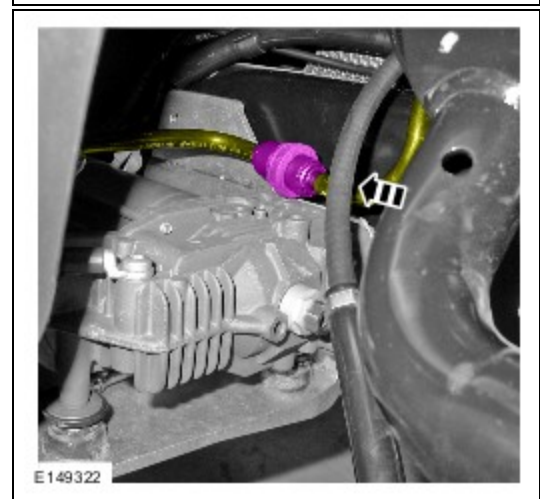

37. Install the air suspension compressor lower cover.

- Secure the five (5) clips.
- Tighten the three (3) bolts to 9 Nm.

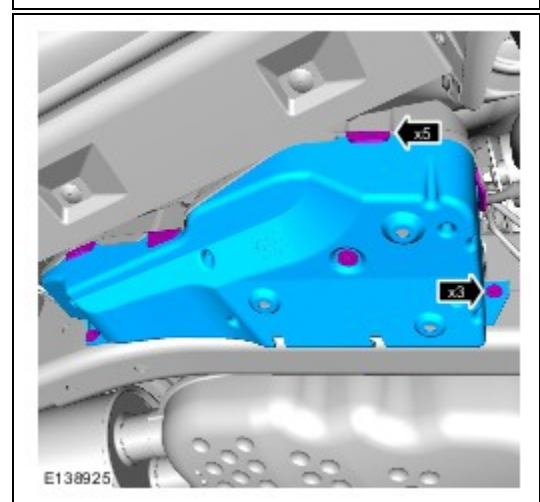

△ **NOTE: STEPS 38-49 FOR ALL VEHICLES.**

38. △ **NOTE: Location of air suspension relay to be replaced.**

Replace the compressor relay.

- The relay is located in the fuse box in the engine bay.



39. ⚠ **CAUTION: Ensure all ignition 'ON' / ignition 'OFF' requests are carried out; failure to perform these steps may cause damage to control modules in the vehicle.**

⚠ **CAUTION: A Land Rover-approved Midtronics Vehicle Power Supply must be connected to the vehicle battery during IDS diagnosis / module programming.**

Connect the Land Rover-approved Midtronics Vehicle Power Supply to the vehicle battery.

40. Turn ignition 'ON' (engine not running).

41. △ **NOTE: IDS must be loaded with DVD131.07 v.118 or later.**

Connect the IDS to the vehicle and begin a new Symptom Driven Diagnostics (SDD) session.

42. Follow the on-screen prompts, allowing SDD to read the VIN and identify the vehicle.

43. From the Session Type selection screen, choose 'Diagnosis'.

44. Select the 'Selected Symptoms' tab, and then select:

- 'Service Function'

45. Select 'continue'.

46. Select the 'Recommendations' tab.

47. ⚠ **CAUTION: During this procedure, if SDD presents a question regarding compressor type, always select the type/manufacturer for the compressor being fitted to the vehicle as part of this repair, which under all circumstances should be an AMK compressor type. If unsure select 'EXIT' at this prompt and repeat this process after the facts are known. Failure to make the correct compressor type selection will cause SDD to install incorrect software.**

From the Recommendations tab, select 'Run' to perform the 'Air suspension – Air suspension compressor replacement' function.

- Follow all on-screen instructions to complete this task.

48. Exit the current session.

49. Disconnect the IDS and the Midtronics Vehicle Power Supply from the vehicle.