



CAN-Bus Troubleshooting Guide



NOTE

The information in this document has been carefully checked and is believed to be entirely reliable. **esd** makes no warranty of any kind with regard to the material in this document, and assumes no responsibility for any errors that may appear in this document. **esd** reserves the right to make changes without notice to this, or any of its products, to improve reliability, performance or design.

esd assumes no responsibility for the use of any circuitry other than circuitry which is part of a product of **esd gmbh**.

esd does not convey to the purchaser of the product described herein any license under the patent rights of **esd gmbh** nor the rights of others.

esd electronic system design gmbh

Vahrenwalder Str. 207
30165 Hannover
Germany

Phone: +49-511-372 98-0
Fax: +49-511-372 98-68
E-mail: info@esd-electronics.com
Internet: www.esd-electronics.com

USA / Canada:

esd electronics Inc.

525 Bernardston Road
Suite 1
Greenfield, MA 01301
USA

Phone: +1-800-732-8006
Fax: +1-800-732-8093
E-mail: us-sales@esd-electronics.com
Internet: www.esd-electronics.us

Document file:	I:\texte\Doku\MANUALS\CAN\VERDRAHT\Englisch\CAN-Troubleshooting\CAN-Troubleshooting_11.en9
Date of print:	2007-06-18

Changes in the chapters

The changes in the document listed below affect changes in the hardware as well as changes in the description of facts only.

Chapter	Changes as compared to previous version
-	Additional notes on CAN-GND.

Technical details are subject to change without further notice.

This page has intentionally been left blank.

Contents

1. CAN-Bus Troubleshooting Guide	6
1.1 Termination	6
1.2 CAN_H/CAN_L Voltage	7
1.3 Ground	7
1.4 CAN Transceiver Resistance Test	8

1. CAN-Bus Troubleshooting Guide

The CAN-Bus Troubleshooting Guide is a guide to find and eliminate the most frequent hardware-error causes in the wiring of CAN-networks.

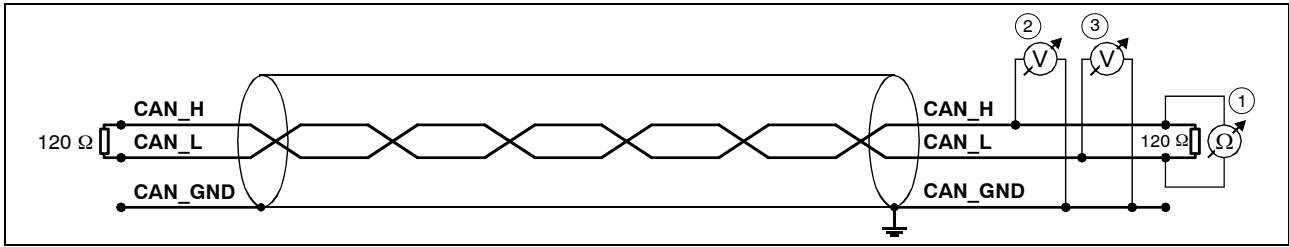

Figure: Simplified diagram of a CAN network

1.1 Termination

The termination is used to match impedance of a node to the impedance of the transmission line being used. When impedance is mismatched, the transmitted signal is not completely absorbed by the load and a portion is reflected back into the transmission line. If the source, transmission line and load impedance are equal these reflections are eliminated. This test measures the series resistance of the CAN data pair conductors and the attached terminating resistors.

To test it, please

1. Turn off all power supplies of the attached CAN nodes.
2. Measure the DC resistance between CAN_H and CAN_L at the middle and ends of the network **1** (see figure above).

The measured value should be between 50 and 70 Ω. The measured value should be nearly the same at each point of the network.

If the value is below 50 Ω, please make sure that:

- there is no short circuit between CAN_H and CAN_L wiring
- there are not more than two terminating resistors
- the nodes do not have faulty transceivers.

If the value is higher than 70 Ω, please make sure that:

- there are no open circuits in CAN_H or CAN_L wiring
- your bus system has two terminating resistors (one at each end) and that they are 120 Ω each.

1.2 CAN_H/CAN_L Voltage

Each node contains a CAN transceiver that outputs differential signals. When the network communication is idle the CAN_H and CAN_L voltages are approximately 2.5 volts. Faulty transceivers can cause the idle voltages to vary and disrupt network communication.

To test for faulty transceivers, please

1. Turn on all supplies.
2. Stop all network communication.
3. Measure the DC voltage between CAN_H and GND **2** (see figure above).
4. Measure the DC voltage between CAN_L and GND **3** (see figure above).

Normally the voltage should be between 2.0 V and 4.0 V.

If it is lower than 2.0 V or higher than 4.0 V, it is possible that one or more nodes have faulty transceivers. For a voltage lower than 2.0 V please check CAN_H and CAN_L conductors for continuity. For a voltage higher than 4.0 V, please check for excessive voltage.

To find the node with a faulty transceiver please test the CAN transceiver resistance (see next page).

1.3 Ground

The shield of the CAN network has to be grounded at only one location. This test will indicate if the shielding is grounded in several places. To test it, please

1. Disconnect the shield wire (Shield) from the ground.
2. Measure the DC resistance between Shield and ground (see picture on the right hand).
3. Connect Shield wire to ground.

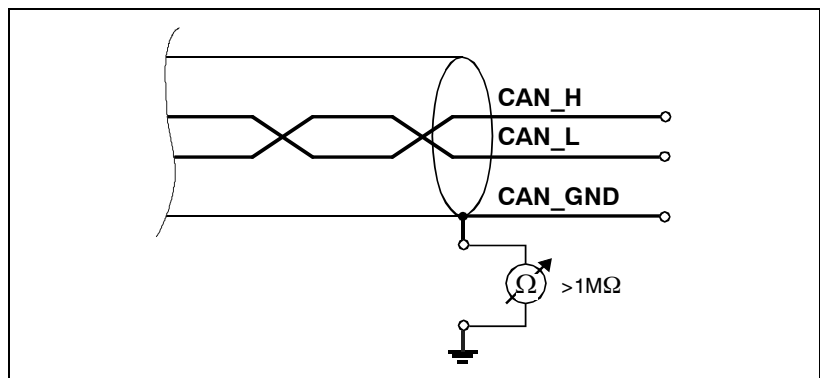

Fig.: Simplified schematic diagram of ground test measurement

The resistance should be higher than 1 M Ω . If it is lower, please search for additional grounding of the shield wires.

1.4 CAN Transceiver Resistance Test

CAN transceivers have one circuit that controls CAN_H and another circuit that controls CAN_L. Experience has shown that electrical damage to one or both of the circuits may increase the leakage current in these circuits.

To measure the current leakage through the CAN circuits, please use an resistance measuring device and:

1. Disconnect the node from the network. Leave the node unpowered (4) (see figure below).
2. Measure the DC resistance between CAN_H and CAN_GND (5) (see figure below).
3. Measure the DC resistance between CAN_L and CAN_GND (6) (see figure below).

Normally the resistance should be between 1 M Ω and 4 M Ω or higher. If it is lower than this range, the CAN transceiver is probably faulty.

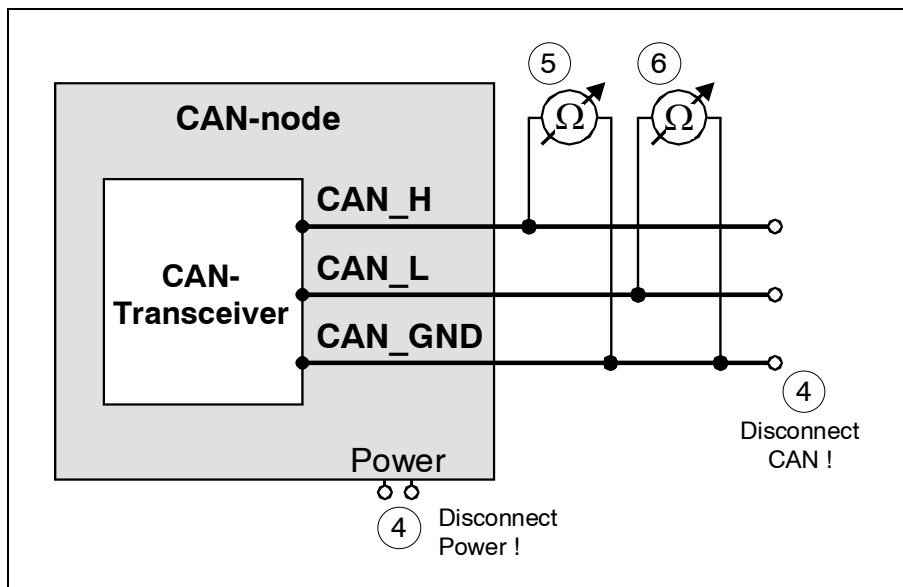

Figure: Simplified diagram of a CAN node