

Safety Belt System -

Torque Specifications

Description	Nm	lb-ft
Front safety belt retractor Torx bolt	40	30
Front safety belt buckle Torx bolt	40	30
+ Front safety belt upper anchor Torx bolt	40	30
Second row safety belt retractor Torx bolt	40	30
+ Second row safety belt upper anchor Torx bolt	40	30
Third row safety belt retractor Torx bolt	40	30
+ Third row safety belt upper anchor Torx bolt	40	30
Luggage compartment Torx bolts	25	18
Rear safety belt buckle Torx bolt	25	18
Rear safety belt buckle - RH - Torx bolt	40	30
Rear safety belt buckle - LH - Torx bolt - 60-40 split	25	18
Rear center safety belt buckle Torx bolt - 40-20-40 split	40	30
Rear safety belt buckle Torx bolt - 40-20-40 split	25	18
+ Rear seat Torx bolts	40	30

+ New Torx bolt must be fitted

Safety Belt System - Safety Belt System

Description and Operation

COMPONENT LOCATIONS (FIVE SEAT VEHICLES)



E44815

COMPONENT LOCATIONS (SEVEN SEAT VEHICLES)

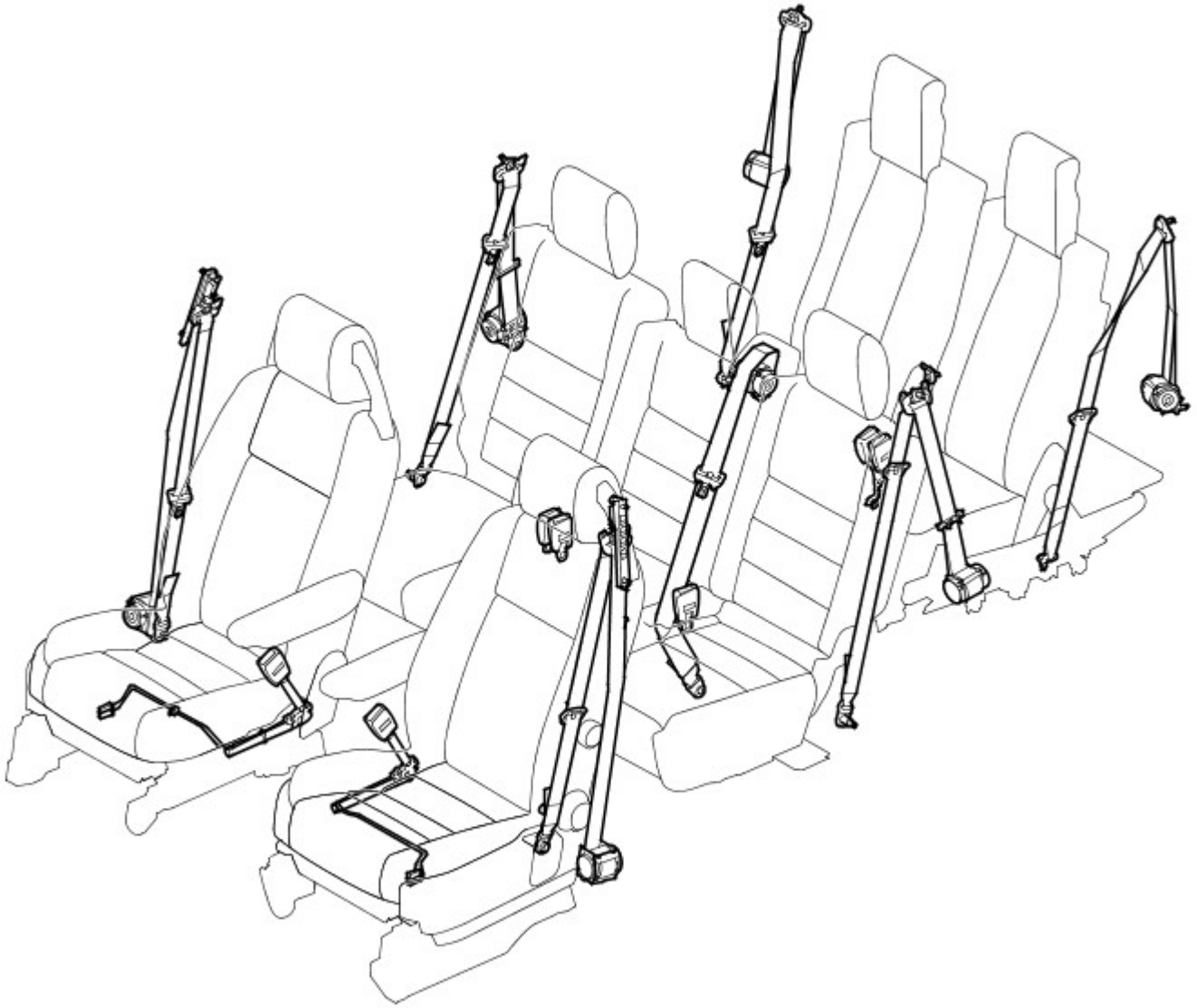

E44835

GENERAL

A three point safety belt is installed at each seat position. Except in North American Specification (NAS) markets, all of the safety belts have Emergency Locking Retractors (ELR). In NAS markets, only the driver seat is fitted with an ELR; all of the passenger safety belts have Automatic Locking Retractors (ALR).

Both types of retractor incorporate a liftshaft locking system with webbing sensor and car sensor activating mechanisms. The webbing sensor activates the locking system if the webbing is subjected to a sharp pull. The car sensor activates the locking system if the vehicle is subjected to sudden deceleration or a severe tilt angle.

The ALR has a mode of operation where the retractor will take up slack in the webbing, but not allow any slack to be paid out. This mode of operation can be used to secure a child seat.

- **To engage the ALR child seat mode of operation:** Pull the webbing out of the retractor to its full extent.
- **To cancel the ALR child seat mode of operation:** Allow the retractor to fully rewind the webbing.

A safety belt warning indicator is installed in the instrument cluster to remind the front seat occupants to fasten their safety belts. On NAS vehicles, when the ignition switch is turned to position II, the warning indicator illuminates if the safety belt of an occupied front seat is not fastened. The warning indicator remains illuminated until the safety belt of each occupied front seat is fastened, or the ignition is switched off. In all markets except NAS, a belt minder function provides a more intrusive reminder to fasten the front safety belts.

FRONT SAFETY BELTS

The retractor of each front safety belt is attached to the related B pillar. The webbing runs from the retractor through an upper mounting, attached to a shoulder height adjuster on the B pillar, to an anchor point on the front seat.

On NAS vehicles, a tension sensor is integrated into the anchor point of the passenger front safety belt. The tension

sensor is part of the occupant classification system.

For additional information, refer to: [Air Bag and Safety Belt Pretensioner Supplemental Restraint System \(SRS\)](#) (501-20B Supplemental Restraint System, Description and Operation).

The retractor for each front safety belt incorporates a load limiter that allows the retractor reel to partially unwind when the load on the webbing exceeds a predetermined limit.

The buckle for each front safety belt is attached to a pretensioner secured to the inboard side of the related front seat frame. Each buckle incorporates a safety belt buckle sensor that provides a status input to the restraints control module, which uses the input to determine the air bag and pretensioner activation strategies. The restraints control module also relays the status of the safety belts to the instrument cluster on the high speed CAN bus.

Belt Minder Function (Where Fitted)

The belt minder function provides warnings to the driver if the appropriate front safety belts are not fastened when driving. The belt minder function is controlled by the instrument cluster using medium speed CAN bus messages, from the restraints control module, to monitor the status of the front safety belts.

When the ignition switch is turned to position II, the instrument cluster illuminates the safety belt warning indicator until one of the front safety belts is fastened or the belt minder function is triggered. The belt minder function is triggered when the ignition switch is in position II and the following conditions coexist:

- The belt minder function is enabled.
- Vehicle speed is 8 km/h (5 mph) or more.
- The vehicle is not in reverse.
- The driver safety belt or, if the front passenger seat is occupied, the front passenger safety belt, is unfastened.

When the belt minder is triggered, the instrument cluster generates the following warnings for 10 seconds.

- Flashes the safety belt warning indicator at 2 Hz.
- Sounds a repeating chime in sequence with the flashing safety belt warning indicator.

After 10 seconds, the repeating chime is discontinued and the safety belt warning indicator changes from flashing to continuously illuminated. While the trigger conditions still coexist, the warnings are repeated every 30 seconds until one of the following occurs:

- 5 minutes has elapsed from when the warnings were first triggered.
- The safety belt of each occupied front seat is fastened.
- The ignition switch is turned to position 0.
- The vehicle speed decreases to 5 km/h (3 mph).

The belt minder function can be enabled and disabled using the driver safety belt switch. The instrument cluster changes the state of the belt minder function if, within 60 seconds of first turning the ignition switch to position II, the driver safety belt is fastened and unfastened nine times. Successful completion of the change is indicated by a single chime and the safety belt warning indicator flashing five times, at 2 Hz. The belt minder function can also be enabled and disabled using T4.

Safety Belt Warning Indicator



SECOND ROW SAFETY BELTS

The retractor of each outboard second row safety belt is attached to the body immediately behind the D pillar. The webbing runs from the retractor, through an upper mounting on the D pillar, to an anchor point at the front of the related wheel arch.

The retractor for the center second row safety belt is installed in the top of the seat back. The webbing runs from the retractor, over the top of the seat, to an anchor point at the base of the seat frame.

The buckles for the second row safety belts are attached to the related seat frame.

THIRD ROW SAFETY BELTS (WHERE FITTED)

The retractor of each third row safety belt is attached to the E pillar. The webbing runs from the retractor, through a mounting on the E pillar to an anchor point on the floor.

The buckles for the third row safety belts are attached to the related seat frame.

Safety Belt System - Safety Belt System

Diagnosis and Testing

Principle of Operation

For a detailed description of the safety belt system and operation, refer to the relevant description and operation section of the workshop manual REFER to: [Safety Belt System](#) (501-20A Safety Belt System, Description and Operation).

Safety Information

• WARNINGS:



To avoid accidental deployment the back-up power supply must be depleted before beginning any work on the SRS system or its components. Failure to follow this instruction may result in personal injury



Do not use a multimeter to probe an SRS module. It is possible for the power from the multimeter battery to trigger the activation of the module. Failure to follow this instruction may result in personal injury

• NOTE: Do not to use a cellular phone or to have a cellular phone in close proximity when working on the SRS system or components

Power supply depletion

Before beginning any work on the SRS system or related components:

1. **1.** Remove the ignition key
2. **2.** Disconnect the battery leads, ground first
3. **3.** Wait 2 minutes for the power circuit to discharge

There are comprehensive instructions on the correct procedures for SRS system repairs, refer to the relevant section of the workshop manual

Inspection and Verification



CAUTION: Diagnosis by substitution from a donor vehicle is **NOT** acceptable. Substitution of control modules does not guarantee confirmation of a fault and may also cause additional faults in the vehicle being checked and/or the donor vehicle

• NOTE: Check and rectify basic faults before beginning diagnostic routines including pinpoint tests

1. **1.** Verify the customer concern by operating the safety belt
2. **2.** Visually inspect for obvious signs of mechanical or electrical damage

Visual Inspection

Mechanical	Electrical
<ul style="list-style-type: none"> ● Check for the installation of non-standard accessories which may affect or obstruct the function of the safety belt system ● Frayed or damaged webbing ● Missing or damaged button stop ● Pretensioner(s) Buckles/Stalks 	<ul style="list-style-type: none"> ● Fuses ● Wiring harness fault ● Correct engagement of electrical connectors ● Loose or corroded connections ● Warning lamp bulb(s) ● Impact sensor(s) ● Buckle sensor(s) ● Pretensioner(s) ● Belt tension sensor(s) ● Restraints control module

3. **3.** If an obvious cause for an observed or reported concern is found, correct the cause (if possible) before proceeding to the next step
4. **4.** If the cause is not visually evident, carry out the test methods described below, alternatively check for diagnostic trouble codes and refer to the relevant diagnostic trouble code index

For a complete list of all diagnostic trouble codes that could be logged on this vehicle, please refer to section 100-00. REFER to: [Diagnostic Trouble Code \(DTC\) Index - DTC: Restraints Control Module \(RCM\)](#) (100-00 General Information, Description and Operation).

Symptom Chart for Safety Belt Rows 1, 2 and 3

Symptom	Possible Causes	Action
Safety belt jammed - Webbing tight	<ul style="list-style-type: none"> ● Backlock effect-in action (webbing retracted quickly and came to sudden stop) ● Safety belt retractor not installed correctly ● Rear centre belt only. Mini-button (webbing travel limit stop) missing and seat squab has been moved 	<ul style="list-style-type: none"> ● GO to Pinpoint Test A. ● GO to Pinpoint Test E. ● GO to Pinpoint Test H. ● See the automatic locking retractor description below

Symptom	Possible Causes	Action
	<ul style="list-style-type: none"> causing tight fit Automatic locking retractor activated (clicking – during retraction only) 	
Seat squab will not fold/jammed	<ul style="list-style-type: none"> • NOTE: Rear centre belt only • Mini-button (webbing travel limit stop) missing and seat squab has been moved causing excessive tension 	<ul style="list-style-type: none"> • GO to Pinpoint Test H.
Safety belt jammed - Webbing loose	<ul style="list-style-type: none"> • Safety belt webbing trapped in seat • Safety belt retractor webbing guide loose • Twist in webbing • Interference in webbing routing • D-loop not rotating correctly 	<ul style="list-style-type: none"> • GO to Pinpoint Test B. • GO to Pinpoint Test C. • GO to Pinpoint Test D. • GO to Pinpoint Test E. • GO to Pinpoint Test G.
Safety belt - Intermittent jamming	<ul style="list-style-type: none"> • Safety belt retractor not installed correctly 	<ul style="list-style-type: none"> • GO to Pinpoint Test F.
Safety belt - Slow retraction	<ul style="list-style-type: none"> • Safety belt retractor webbing guide loose • Twist in safety belt webbing • Interference in webbing routing • Safety belt retractor not installed correctly • D-loop not rotating correctly • Foreign object/debris 	<ul style="list-style-type: none"> • GO to Pinpoint Test C. • GO to Pinpoint Test D. • GO to Pinpoint Test E. • GO to Pinpoint Test F. • GO to Pinpoint Test G. • GO to Pinpoint Test E.
Safety belt - Not retracting	<ul style="list-style-type: none"> • Safety belt retractor webbing guide loose • Twist in safety belt webbing • D-loop not rotating correctly • Interference in webbing routing • Foreign object/debris 	<ul style="list-style-type: none"> • GO to Pinpoint Test C. • GO to Pinpoint Test D. • GO to Pinpoint Test G. • GO to Pinpoint Test E. • GO to Pinpoint Test E.
Safety Belt - Not extracting	<ul style="list-style-type: none"> • Backlock effect-in action (webbing retracted quickly and came to sudden stop) • Safety belt retractor not installed correctly • Safety belt retractor webbing guide loose • Twist in safety belt webbing • D-loop not rotating correctly • Interference in webbing routing • Foreign object/debris • Automatic locking retractor activated (clicking – during retraction only) 	<ul style="list-style-type: none"> • GO to Pinpoint Test A. • GO to Pinpoint Test F. • GO to Pinpoint Test C. • GO to Pinpoint Test D. • GO to Pinpoint Test G. • GO to Pinpoint Test E. • GO to Pinpoint Test E. • See the automatic locking retractor description below
Safety belt - Noisy during operation	<ul style="list-style-type: none"> • Automatic locking retractor activated (clicking–during retraction only) • Interference in webbing routing (rubbing) 	<ul style="list-style-type: none"> • GO to Pinpoint Test B. • GO to Pinpoint Test E.
Safety belt buckle - Not latching / jammed	<ul style="list-style-type: none"> • Foreign object/debris 	 CAUTION: Do not insert any objects or tools into the buckle head <ul style="list-style-type: none"> • GO to Pinpoint Test I.

Inertia Reel Safety Belts

The vehicle is equipped with (two row one), (three row two), and (two row three (seven seat versions only)) inertia reel safety belts

These safety belts are "**dual sensitive**" which means that they have:

- **Car sense system - A vehicle motion sensor, which locks the safety belt webbing under braking, cornering, on steep hills and in adverse camber conditions, when parked on a steep incline or driveway or two wheels on a high curb**
- **Webb sense system - A webbing motion sensor, which locks when the safety belt webbing is extracted suddenly**

The safety belts in the following positions are equipped with an automatic locking retractor function:

Carline	Market	Seat position	Automatic Locking Retractor Installed	From Model Year
Defender (L316)	All	All	No	2007
Discovery / Range Rover Sport (L319/L320)	All	Driver	No	2008
Discovery / Range Rover Sport (L319/L320)	US	Passenger	Yes	2005
Discovery / Range Rover Sport (L319/L320)	All	Driver	No	2005
Discovery / Range Rover Sport (L319/L320)	ROW	Passenger	No	2005
Discovery (L319)	All	Row 2	Yes	2005
Discovery (L319)	All	Row 3	Yes	2005
Range Rover Sport (L320)	All	Row 2	Yes	2006
Freelander (L359)	All	Driver	No	2007
Freelander (L359)	ROW	Passenger	No	2007
Freelander (L359)	US	Passenger	Yes	2007
Freelander (L359)	ROW	Row 2	No	2007
Freelander (L359)	US	Row 2	Yes	2007

Carline	Market	Seat position	Automatic Locking Retractor Installed	From Model Year
Range Rover Evoque (L358)	All	Driver	No	2011
Range Rover Evoque (L358)	ROW	Passenger	No	2011
Range Rover Evoque (L358)	US	Passenger	Yes	2011
Range Rover Evoque (L358)	ROW	Row 2	No	2011
Range Rover Evoque (L358)	US	Row 2	Yes	2011
Range Rover (L322)	All	Driver	No	2003
Range Rover (L322)	ROW	Passenger	No	2003
Range Rover (L322)	US	Passenger	Yes	2003
Range Rover (L322)	ROW	Row 2	No	2003
Range Rover (L322)	US	Row 2	Yes	2003

The **automatic locking retractor function** is a feature to secure a child seat or heavy load to the seat

Activation	Deactivation
<ul style="list-style-type: none"> NOTE: When automatic locking retractor is activated, no further webbing can be drawn from the safety belt retractor, prior to disengagement of the automatic locking. This can be mistaken as a jammed safety belt retractor 	Automatic locking retractor is deactivated by allowing the webbing to retract until the clicking stops (close to park position)
Activated by total extraction of the webbing	
When activated the automatic locking retractor is identified by a clicking noise during webbing retraction	When deactivated the automatic locking retractor safety belt changes state, from a static safety belt to an automatic safety belt

Safety Belt Locking Test

With the vehicle stationary and on level ground take firm hold of the safety belt webbing (on the tongue side of the upper safety belt anchor) and withdraw sharply, **the retractor should lock**. Preventing further webbing release (**repeat this test 3 times**). Any safety belt retractor which fails to lock **must not be used** and a **new safety belt must be installed**.

DTC Index

For a list of diagnostic trouble codes that could be logged on this vehicle, please refer to Section 100-00 or for removal and installation/description and operation see Section 501-20

Diagnostic Guide Inertia Reel Safety Belts

PINPOINT TEST A : BACKLOCK	
TEST CONDITIONS	DETAILS/RESULTS/ACTIONS
A1: BACKLOCK	
	<ol style="list-style-type: none"> 1 Visually inspect the condition of the suspect safety belt 2 Draw a maximum of 20mm of the webbing from the safety belt retractor with moderate force. Then release the webbing 3 Check for correct operation twice
	Does the webbing move freely then retract correctly? Yes No further action required No For first row safety belt GO to Pinpoint Test C . For second and third row safety belts GO to Pinpoint Test B .

PINPOINT TEST B : WEBBING-TRAPPED IN SEAT	
TEST CONDITIONS	DETAILS/RESULTS/ACTIONS
B1: WEBBING-TRAPPED IN SEAT	
	<ol style="list-style-type: none"> 1 Visually inspect the condition of the suspect safety belt 2 Lift the seat base or release the seat backrest as required 3 Free the trapped webbing, allow the webbing to retract Note: If the automatic locking retractor is activated, allow the webbing to retract until the clicking stops 4 Check for correct operation twice
	Does the webbing move freely then retract correctly? Yes No further action required No GO to Pinpoint Test C .

PINPOINT TEST C : SAFETY BELT RETRACTOR-WEBBING GUIDE LOOSE	
TEST CONDITIONS	DETAILS/RESULTS/ACTIONS
C1: SAFETY BELT RETRACTOR-WEBBING GUIDE LOOSE	
	<ol style="list-style-type: none"> 1 Refer to 501-20 removal and installation section of the workshop manual, remove any trim panels required to expose the D loop (anchor point) and safety belt retractor 2 Check the webbing is not trapped or twisted and is centrally located on the safety belt retractor spindle 3 Attempt to withdraw the webbing from the safety belt retractor NOTE: If the safety belt webbing is jammed, the automatic locking retractor could be engaged 4 To release the automatic locking retractor, manually wind the webbing onto the spindle until the automatic locking retractor deactivates (clicking stops) 5 Fully extract webbing

	6 Confirm webbing guide location is correct , Confirm the fixing lugs are correctly located in the retractor frame
	7 Allow webbing to retract
	8 Check for correct operation twice
	Does the webbing move freely then retract correctly? Yes Refer to the 501-20 removal and installation section of the workshop manual, reinstall any trim panels, ensure there are no obstructions and the webbing does not catch or rub. No further action required No GO to Pinpoint Test D.

PINPOINT TEST D : TWIST IN WEBBING	
TEST CONDITIONS	DETAILS/RESULTS/ACTIONS
D1: TWIST IN WEBBING	
	1 Refer to section 501-20 removal and installation section of the workshop manual, remove any trim panels required to expose the D loop (anchor point)
	2 Twist the webbing back the correct way in the loop
	3 Pass the twist through the pillar loop or escutcheon as required
	4 Check for correct operation twice
	Does the webbing move freely then retract correctly? Yes Refer to the 501-20 removal and installation section of the workshop manual, reinstall any trim panels, ensure there are no obstructions and the webbing does not catch or rub. No further action required No GO to Pinpoint Test E.

PINPOINT TEST E : INTERFERENCE-WEBBING ROUTING	
TEST CONDITIONS	DETAILS/RESULTS/ACTIONS
E1: INTERFERENCE-WEBBING ROUTING	
	1 Refer to the 501-20 removal and installation section of the workshop manual, remove any trim panels required to expose the D loop (anchor point)
	2 Remove obstructions and foreign objects ensure the webbing does not catch or rub
	3 Confirm the safety belt does not contact the wiring harness
	4 Check for correct operation twice
	Does the webbing move freely then retract correctly? Yes Refer to the 501-20 removal and installation section of the workshop manual, reinstall any trim panels, ensure there are no obstructions and the webbing does not catch or rub. No further action required No GO to Pinpoint Test E.

PINPOINT TEST F : SAFETY BELT RETRACTOR-INCORRECT INSTALLATION	
TEST CONDITIONS	DETAILS/RESULTS/ACTIONS
F1: SAFETY BELT RETRACTOR-INCORRECT INSTALLATION	
	1 Refer to the 501-20 removal and installation section of the workshop manual, remove any trim panels required to expose the D loop (anchor point) and the safety belt retractor
	2 Refer to the 501-20 removal and installation section of the workshop manual, correctly reinstall the safety belt retractor ensure that the locating "T bar" and "anti rotation pins" are correctly located
	3 Check for correct operation twice
	Does the webbing move freely then retract correctly? Yes Refer to the 501-20 removal and installation section of the workshop manual, reinstall any trim panels, ensure there are no obstructions and the webbing does not catch or rub. No further action required No Replace as required. Refer to the warranty policy and procedures manual, or determine if any prior approval programme is in operation, prior to the installation of a new module/component

PINPOINT TEST G : D-LOOP NOT ROTATING CORRECTLY	
TEST CONDITIONS	DETAILS/RESULTS/ACTIONS
G1: D-LOOP NOT ROTATING CORRECTLY	
	1 Refer to the 501-20 removal and installation section of the workshop manual, remove any trim panels required to expose the D loop (anchor point) and the safety belt retractor
	2 Ensure there are no obstructions and the webbing does not catch or rub, the D loop (anchor point) rotates correctly and if installed the confirm the height adjuster operates correctly
	3 Check for correct operation twice
	Does the webbing move freely then retract correctly? Yes Refer to the 501-20 removal and installation section of the workshop manual, reinstall any trim panels, ensure there are no obstructions and the webbing does not catch or rub. No further action required No

Replace as required. Refer to the warranty policy and procedures manual, or determine if any prior approval programme is in operation, prior to the installation of a new module/component

PINPOINT TEST H : MINI BUTTON-MISSING/DAMAGED

TEST CONDITIONS	DETAILS/RESULTS/ACTIONS
H1: MINI BUTTON-MISSING/DAMAGED	
• NOTE: This test applies to the rear centre safety belt retractor installed in the seat back	
	<ol style="list-style-type: none"> <li data-bbox="304 311 1479 383">1 Refer to the 501-20 removal and installation section of the workshop manual, remove the seat cushion and the plastic escutcheon at the top of the seat back (where the webbing exits to expose the lower anchor fixing point of the center safety belt) <li data-bbox="304 383 1479 412">2 Remove the lower anchorage of the safety belt <li data-bbox="304 412 1479 443">3 With the seat back correctly latched, allow up to 20mm webbing to retract, then extract the webbing
	<p>Is the mini-button (webbing travel limit stop) correctly installed to the webbing and in good condition?</p> <p>Yes Feed the mini-button back through the plastic escutcheon if required. Correctly reinstall the escutcheon to the seat back, extract the webbing then allow to retract, ensure the mini-button comes to rest outside the escutcheon stop</p> <p>No Replace as required. Refer to the warranty policy and procedures manual, or determine if any prior approval programme is in operation, prior to the installation of a new module/component</p>

PINPOINT TEST I : SAFETY BELT BUCKLE-NOT LATCHING/JAMMED

TEST CONDITIONS	DETAILS/RESULTS/ACTIONS
I1: SAFETY BELT BUCKLE-NOT LATCHING/JAMMED	
 CAUTION: Do not insert any objects or tools into the buckle head	
	<ol style="list-style-type: none"> <li data-bbox="304 824 1479 853">1 Visually inspect the buckle head for evidence of damage. If damaged replace as required <li data-bbox="304 853 1479 902">2 Depress the buckle release (red button) and (Using a torch) carry out visual inspection for any evidence of debris/material or foreign objects in the buckle head <li data-bbox="304 902 1479 952">3 If required remove the pretensioner from the vehicle. Remove the seat. Remove the pretensioner from the seat frame <li data-bbox="304 952 1479 1001">4 Do not insert any objects or tools buckle head With the buckle removed invert and attempt to shake out any debris <li data-bbox="304 1001 1479 1032">5 Attempt to latch the tongue in the buckle
	<p>Does the seat belt buckle operate correctly</p> <p>Yes Reinstall any components, no further action required</p> <p>No Replace the pretensioner, Refer to section 501 20</p>

Safety Belt System - Front Safety Belt Retractor

Removal and Installation

Removal

1. Position the front seat fully forwards.
2. Make the SRS system safe.
For additional information, refer to: [Standard Workshop Practices](#) (100-00 General Information, Description and Operation).
3. Remove the B-pillar upper trim panel.
For additional information, refer to: [B-Pillar Upper Trim Panel](#) (501-05 Interior Trim and Ornamentation, Removal and Installation).
4. Release the safety belt upper anchor from the B-pillar.
 - Remove and discard the Torx bolt.



5. Release the front seat switch pack trim panel for access.
 - Remove the 2 screws.

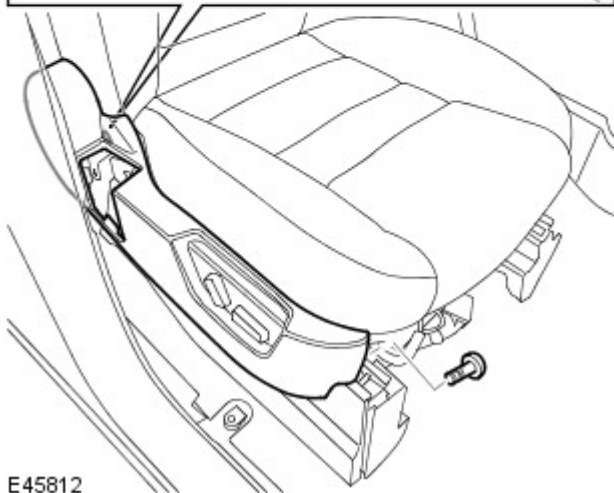
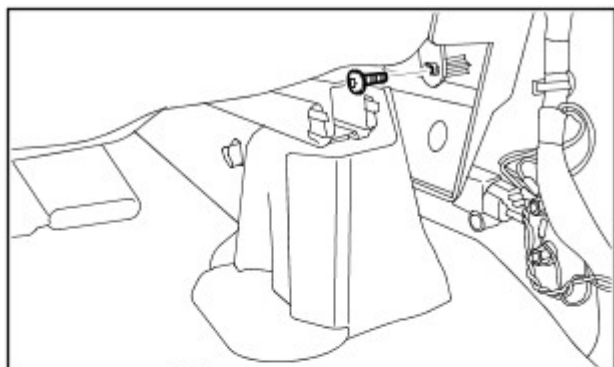

6. Remove the front safety belt retractor.

- Remove and discard the Torx bolt.

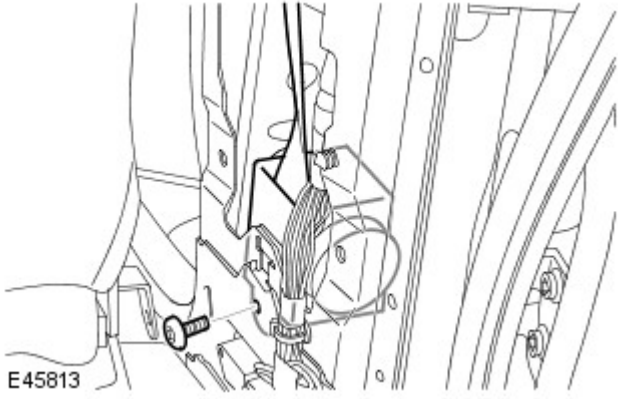

E45813

Installation

1. Install the front safety belt retractor.

- Tighten the Torx bolt to 40 Nm (30 lb.ft).

2. Install the front seat switch pack trim panel.

- Tighten the screws.

3. Attach the safety belt upper anchor.

- Tighten the Torx bolt to 40 Nm (30 lb.ft).

4. Install the B-pillar upper trim panel.

For additional information, refer to: [B-Pillar Upper Trim Panel](#) (501-05 Interior Trim and Ornamentation, Removal and Installation).

Safety Belt System - Second Row Center Safety Belt Retractor Vehicles With: 60/40 Split Seat

Removal and Installation

Removal

1. Release the safety belt retractor cover and guide

- Remove the 2 screws.
- Remove the safety belt guide.
- Remove the retractor cover.

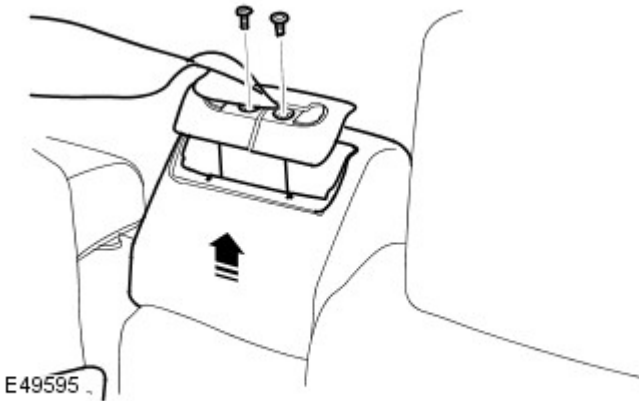

2. Remove the safety belt lower anchor.

- Raise the seat cushion.
- Remove and discard the nut.

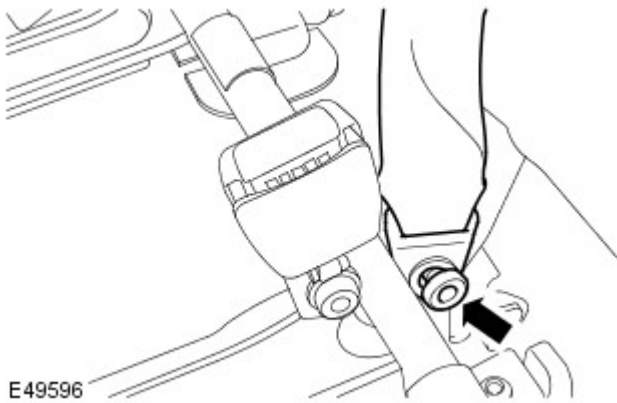

3. Remove the safety belt retractor assembly.

- Remove and discard the Torx bolt.

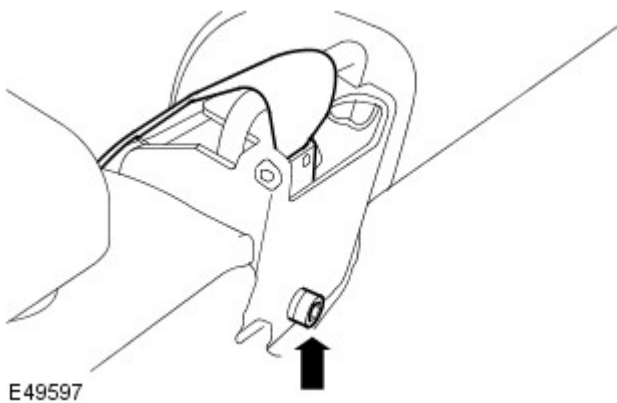

Installation

1. Install the safety belt retractor assembly.

- Tighten the new Torx bolt to 40 Nm (30 lb.ft).

2. Install the safety belt guide and retractor cover.

- Attach the safety belt guide and retractor cover.
- Tighten the screws.

3. Install the safety belt lower anchor.

- Tighten the new nut to 40 Nm (30 lb.ft).
- Lower the seat cushion.

Safety Belt System - Second Row Center Safety Belt Retractor Vehicles With: 40/20/40 Split Seat

Removal and Installation

Removal

1. Remove the center seat.
For additional information, refer to: [Rear Seat - Vehicles With: 40/20/40 Split Seat](#) (501-10 Seating, Removal and Installation).
2. Release the safety belt retractor cover and guide

- Remove the 2 screws.
- Remove the safety belt guide.
- Remove the retractor cover.

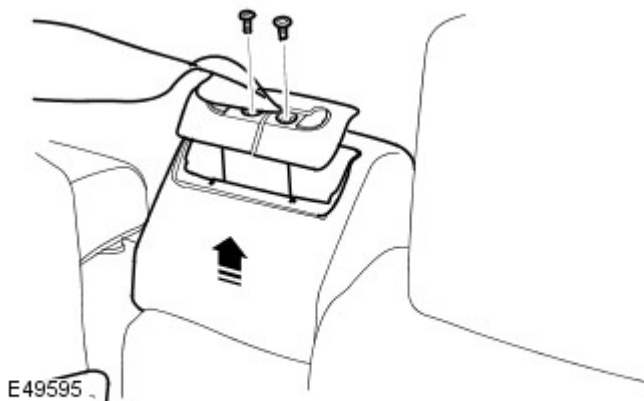

3. Remove the safety belt lower anchor.

- Fold the LH outer seat assembly forwards.
- Remove and discard the Torx bolt.

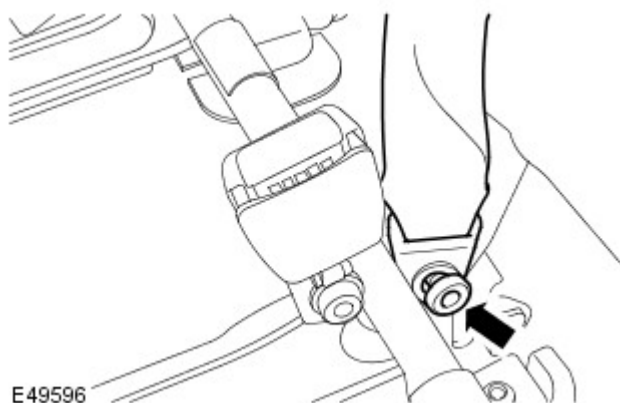

4. Remove the safety belt retractor assembly.

- Remove and discard the Torx bolt.

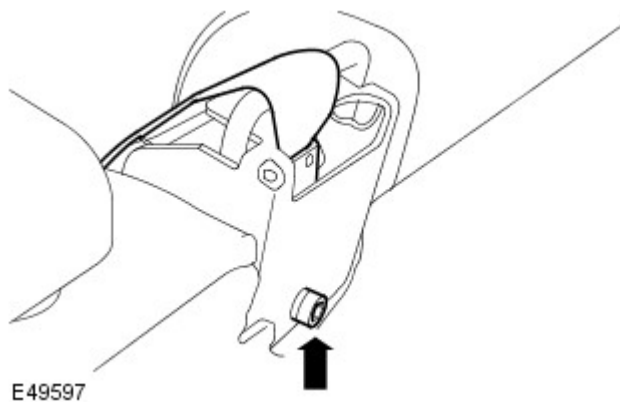

Installation

1. Install the safety belt retractor assembly.
 - Tighten the new Torx bolt to 40 Nm (30 lb.ft).
2. Install the safety belt guide and retractor cover.

- Attach the safety belt guide and retractor cover.
 - Tighten the screws.
- 3.** Install the safety belt lower anchor.
- Tighten the new nut to 40 Nm (30 lb.ft).
 - Lower the seat cushion.
- 4.** Install the center seat.
For additional information, refer to: [Rear Seat - Vehicles With: 40/20/40 Split Seat](#) (501-10 Seating, Removal and Installation).

Safety Belt System - Second Row Safety Belt Retractor

Removal and Installation

Removal

1. Remove the C-pillar upper trim panel.
For additional information, refer to: [C-Pillar Upper Trim Panel](#) (501-05 Interior Trim and Ornamentation, Removal and Installation).
2. Remove the C-pillar lower trim panel.
For additional information, refer to: [C-Pillar Lower Trim Panel](#) (501-05 Interior Trim and Ornamentation, Removal and Installation).
3. Release the safety belt upper anchor.
 - Remove and discard the Torx bolt.

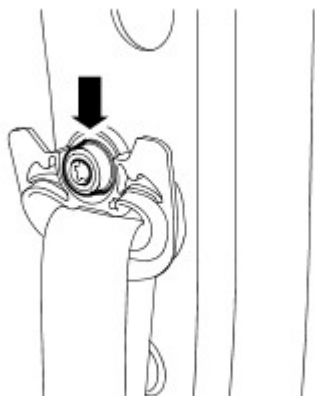

E49593

4. Remove the second row safety belt retractor.
 - Remove and discard the Torx bolt.



E49594

Installation

1. Install the second row safety belt retractor.
 - Tighten the Torx bolt to 40 Nm (30 lb.ft).
2. Install the safety belt upper anchor.
 - Tighten the Torx bolt to 40 Nm (30 lb.ft).
3. Install the C-pillar lower trim panel.
For additional information, refer to: [C-Pillar Lower Trim Panel](#) (501-05 Interior Trim and Ornamentation, Removal and Installation).
4. Install the C-pillar upper trim panel.
For additional information, refer to: [C-Pillar Upper Trim Panel](#) (501-05 Interior Trim and Ornamentation, Removal and Installation).

Safety Belt System - Third Row Safety Belt Retractor

Removal and Installation

Removal

1. Remove the D-pillar upper trim panel.
For additional information, refer to: [D-Pillar Trim Panel](#) (501-05 Interior Trim and Ornamentation, Removal and Installation).
2. Release the safety belt upper anchor.
 - Remove and discard the Torx bolt.

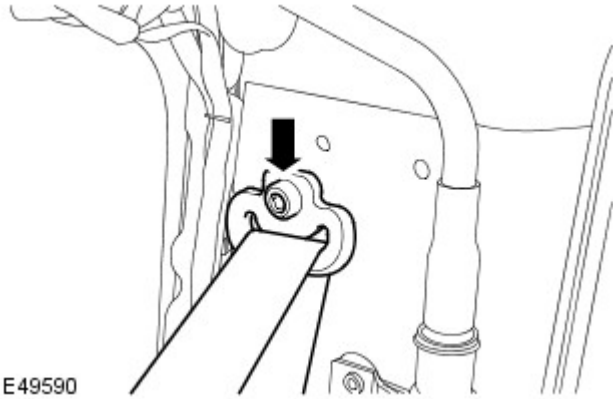

3. Remove the third row safety belt retractor.
 - Remove and discard the Torx bolt.

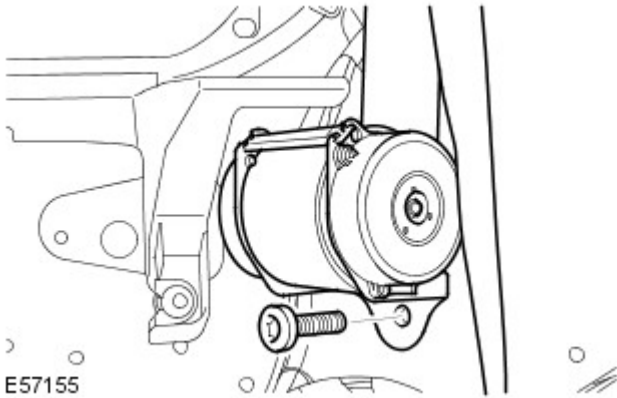

Installation

1. Install the third row safety belt retractor.
 - Tighten the Torx bolt to 40 Nm (30 lb.ft).
2. Install the safety belt upper anchor.
 - Tighten the Torx bolt to 40 Nm (30 lb.ft).
3. Install the D-pillar upper trim panel.
For additional information, refer to: [D-Pillar Trim Panel](#) (501-05 Interior Trim and Ornamentation, Removal and Installation).

Safety Belt System - Front Safety Belt Buckle

Removal and Installation

Removal

• WARNINGS:



It is imperative that before any work is undertaken on the SRS system, the appropriate information is read thoroughly.



Always disconnect both battery cables before beginning work on the SRS system. Disconnect the ground cable first. Never reverse connect the battery.

1. Disconnect the battery ground cable.
For additional information, refer to: [Specifications](#) (414-00 Battery and Charging System - General Information, Specifications).
2. Make the SRS system safe.
For additional information, refer to: [Standard Workshop Practices](#) (100-00 General Information, Description and Operation).
3. Remove the front seat.
For additional information, refer to: [Front Seat](#) (501-10 Seating, Removal and Installation).
4. Remove the seat backrest hinge cover.
 - Remove the 2 screws.

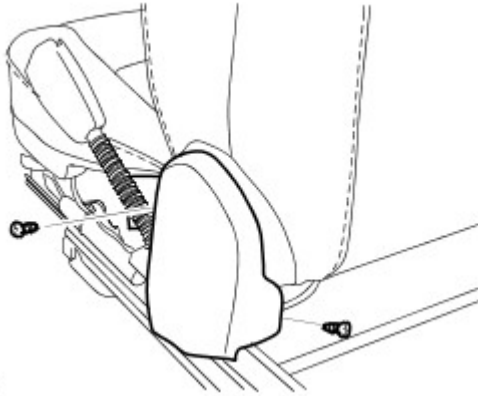

E56486

5. Remove the front safety belt buckle.

- Remove the Torx bolt.
- Disconnect the 2 electrical connectors.
- Release the wiring harness.

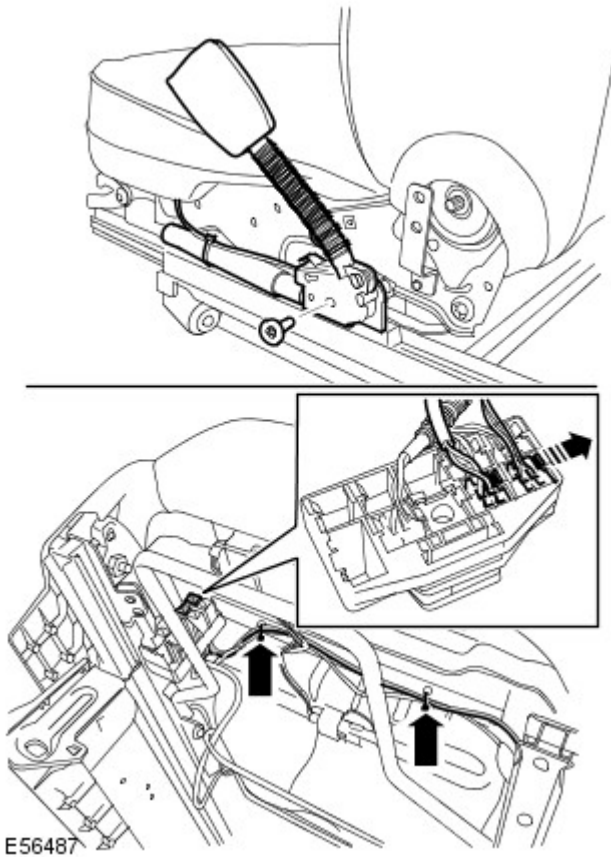

Installation

1. Install the front safety belt buckle.

- Tighten the Torx bolt to 40 Nm (30 lb.ft).
- Connect the electrical connectors.
- Attach the wiring harness.

2. Install the seat backrest hinge cover.

- Tighten the screws.

3. Install the front seat.

For additional information, refer to: [Front Seat](#) (501-10 Seating, Removal and Installation).

4. Connect the battery ground cable.

Safety Belt System - Rear Safety Belt Buckle Vehicles With: 40/20/40 Split Seat

Removal and Installation

Removal

1. Remove the inner backrest hinge cover.

- Release the backrest cover side clip.
- Remove the screw.
- Release the 2 clips.

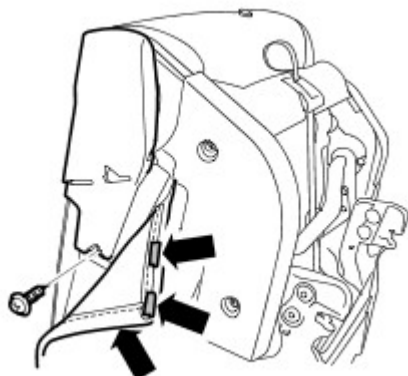

E55971

2. Remove the rear seat cushion side finisher.

- Remove the 2 screws.
- Release the tension strap.

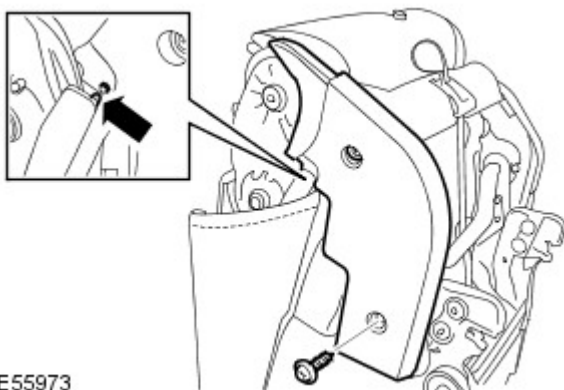

E55973

3. Remove the safety belt buckle.

- Fold the seat assembly forwards.
- Remove the Torx bolt.
- Release the tension spring.

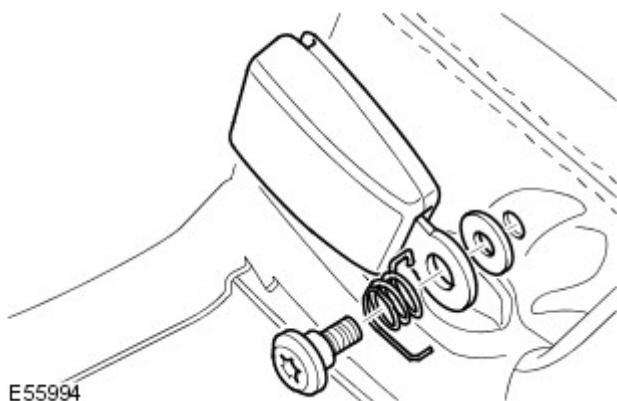

E55994

Installation

1. Install the safety belt buckle.

- Attach the tension spring.
- Tighten the Torx bolt to 25 Nm (18 lb.ft).
- Fold seat assembly rearwards.

2. Install the rear seat cushion side finisher.

- Attach the tension strap.
- Tighten the screws.

3. Install the inner backrest hinge cover.

- Attach the clips.
- Tighten the screw.
- Attach the backrest cover side clip.

Safety Belt System - Rear Safety Belt Buckle LH Vehicles With: 60/40 Split Seat

Removal and Installation

Removal

1. Remove the safety belt buckle.

- Raise the seat cushion.
- Release the retaining strap.
- Remove the Torx bolt.
- Release the tension spring.

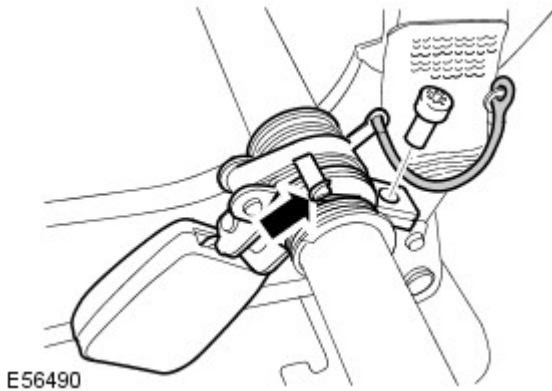

Installation

1. Install the safety belt buckle.

- Attach the tension spring.
- Tighten the Torx bolt to 25 Nm (18 lb.ft).
- Attach the retaining strap.
- Lower the seat cushion.

Safety Belt System - Rear Safety Belt Buckle RH Vehicles With: 60/40 Split Seat

Removal and Installation

Removal

1. Release the RH rear seat.

- Fold the seat cushion forward.
- Remove and discard the 4 Torx bolts.
- Fold down the rear seat backrest.

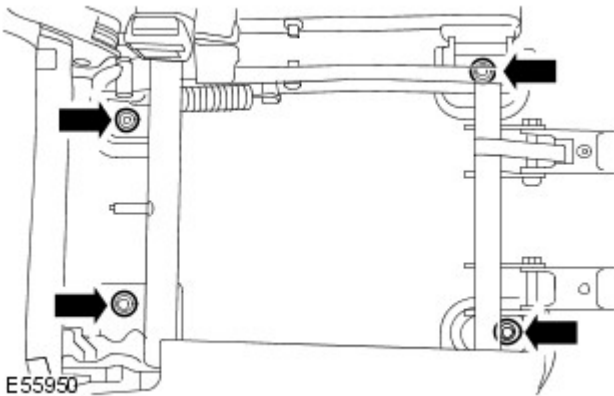

2. Remove the RH rear seat.

3. Remove the rear seat cushion side finisher.

- Remove the screw.

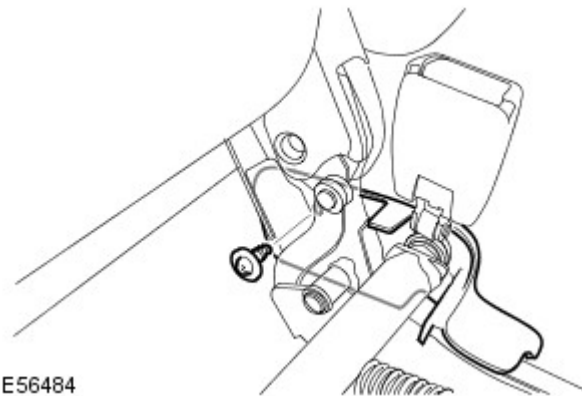

4. Remove the safety belt buckle.

- Raise the seat cushion.
- Release the retaining strap.
- Remove and discard the bolt.

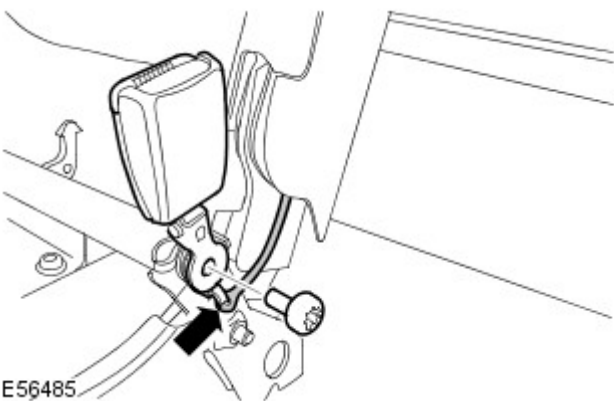

Installation

1. Install the safety belt buckle.

- Tighten the Torx bolt to 40 Nm (30 lb.ft).
- Attach the retaining strap.
- Lower the seat cushion.

2. Install the rear seat cushion side finisher.

- Tighten the screw.

3. Install the RH rear seat.

- Position the seat on the dowels.

4. Secure the RH rear seat.

- Return the seat backrest to the upright position.
- Tighten the new bolts to 40 Nm (30 lb.ft).
- Fold the seat cushion rearwards.

Safety Belt System - Rear Center Safety Belt Buckle Vehicles With: 60/40 Split Seat

Removal and Installation

Removal

1. Release the RH rear seat.

- Fold the seat cushion forward.
- Remove and discard the 4 Torx bolts.
- Fold down the rear seat backrest.

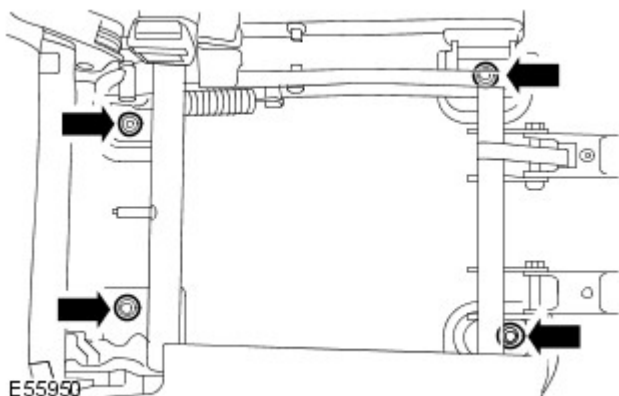

2. Remove the RH rear seat.

3. Remove the rear seat cushion side finisher.

- Raise the seat cushion.
- Remove the screw.

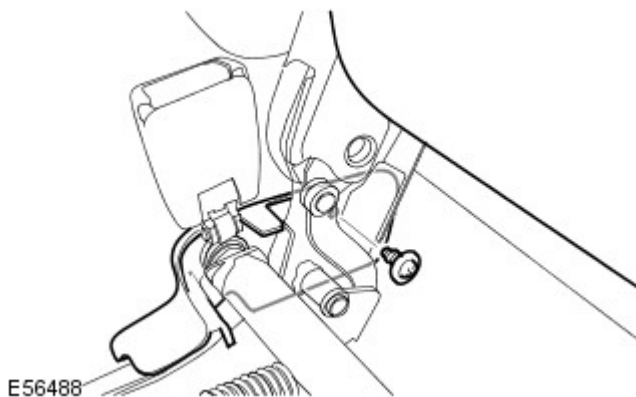

4. Remove the safety belt buckle.

- Release the retaining strap.
- Remove and discard the bolt.

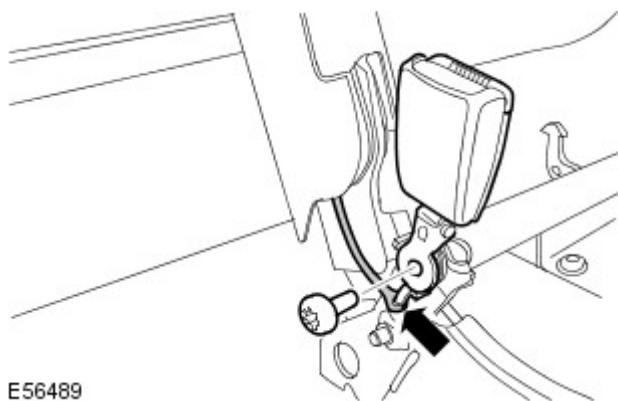

Installation

1. Install the safety belt buckle.

- Tighten the Torx bolt to 40 Nm (30 lb.ft).
- Attach the retaining strap.
- Lower the seat cushion.

2. Install the rear seat cushion side finisher.

- Tighten the screw.

3. Install the RH rear seat.

- Position the seat on the dowels.

4. Secure the RH rear seat.

- Return the seat backrest to the upright position.
- Tighten the new bolts to 40 Nm (30 lb.ft).
- Fold the seat cushion rearwards.