



TECHNICAL BULLETIN

No: LA204-006
Issue: 1
Date: 12 Sep 2006

CIRCULATE: TO

Service Mgr
X

Warranty
X

Workshop
X

Body Shop
X

Parts
X

SECTION: 204-04 **WHEELS AND TIRES**

Steering Wheel Vibration

AFFECTED VEHICLE RANGE:

LR3 (LA)

VIN: ALL

CONDITION SUMMARY:

TIRE FLAT-SPOTTING RESULTS IN STEERING VIBRATION

Situation: This bulletin addresses concerns of a steering wheel vibration/steering shimmy identified on the initial vehicle preparation road test or from a customer complaint. Tire flat-spots are a likely cause.

Action: Carry out the Repair Procedure to correctly diagnose tire flat-spots and wheel balancing requirements.

PARTS:

Locally sourced wheel weights as required

TOOLS:

Hunter 9700/9712 wheel balance machine



To ensure that the wheel/tire assembly is balanced correctly, Land Rover recommends the use of a five fingered clamp to support the wheel and tire assembly on the balance machine. (Figure 1)

Haweka 9700 hub to wheel adapter (Figure 2)

Figure 1



Figure 2



NOTE: The information in Technical Bulletins is intended for use by trained, professional technicians with the knowledge, tools, and equipment required to do the job properly and safely. It informs these technicians of conditions that may occur on some vehicles, or provides information that could assist in proper vehicle service. The procedures should not be performed by "do-it-yourselfers." If you are not a Retailer, do not assume that a condition described affects your vehicle. Contact an authorized Land Rover service facility to determine whether the bulletin applies to a specific vehicle.



WARRANTY:

△ NOTE: Repair procedures are under constant review, and therefore times are subject to change; those quoted here must be taken as guidance only. Always refer to DDW to obtain the latest repair time.

△ NOTE: Steps 1 to 5 of the procedure are part of the Vehicle Preparation process. No claim should be initiated if the performance of these steps at initial vehicle preparation resolves the concern.

DDW requires the use of causal part numbers.

Labor only claims must show the causal part number with a quantity of zero.

<i>Description</i>	<i>SRO</i>	<i>Time (Hours)</i>	<i>Condition Code</i>	<i>Causal Part</i>
Steering wheel vibration/steering shimmy	74.10.89/39	2.20	D9	RTB500220

Normal warranty policy and procedures apply.

REPAIR PROCEDURE

VEHICLE PREPARATION STEPS

△ NOTE: Step 1 of the procedure is part of the Vehicle Preparation process. No claim should be initiated if the performance of this step at initial vehicle preparation resolves the concern.

△ NOTE: Until flat-spots are removed, significant shimmy may be present, even if the car has only stood overnight. A test drive is required to ensure temporary tire flat spots are removed. For longer term flat-spots, a longer drive may be required. The test drive should be carried out on normal open roads to allow the highest speed that speed limits and road/traffic conditions allow.

1. If the vehicle is undergoing initial vehicle preparation, perform the following as part of the test drive:
 - Refer to the Vehicle Preparation Manual and adjust the tire pressures to the recommended cold tire pressures.
 - Drive the vehicle for at least 15km (10 miles) before attempting to assess shimmy.
 - Assess the level of wheel vibration.
2. If a customer complaint is being resolved, perform the following:
 - Adjust the tire pressures to the recommended cold tire pressures.
 - Drive the vehicle for at least 15km (10 miles) before attempting to assess shimmy.
 - Assess the level of wheel vibration.
3. If the level of steering vibration is considered acceptable, no further action is required.
4. If the levels of vibration remain unacceptable, perform the "Balance Wheels" section below.

BALANCE WHEELS AS REQUIRED

1. Raise vehicle on the lift immediately on returning to the workshop, to avoid inducing further tire flat spots.
2. Remove all four road wheel and tire assemblies for balancing.
3. Inflate each tire to **2.5bar (36lbf/in²) +/- 0.1bar (1lbf/in²)**.

NOTE: For adhesive weights, use the attachment arm on the Hunter machine to ensure accurate weight positioning.

4. Refer to Figures 3, 4 and 5 for correct wheel fitting attachment to the balance machine and balance road wheel and tire assemblies until the residual imbalance dynamic is minimized.
 - Target is 0g on each plane, maximum is inner 5g, outer 5g.
 - Use the 'bulls-eye' balancing mode to minimize residual imbalance.
5. If tire road force variations (RFV) measuring is available, the road wheel and tire assembly should aim for a maximum of **60 Newton (6.1 kgf / 13.4 lbf)** first harmonic RFV, **100 Newton (10.2 kgf / 22.5 lbf)** peak-to-peak.

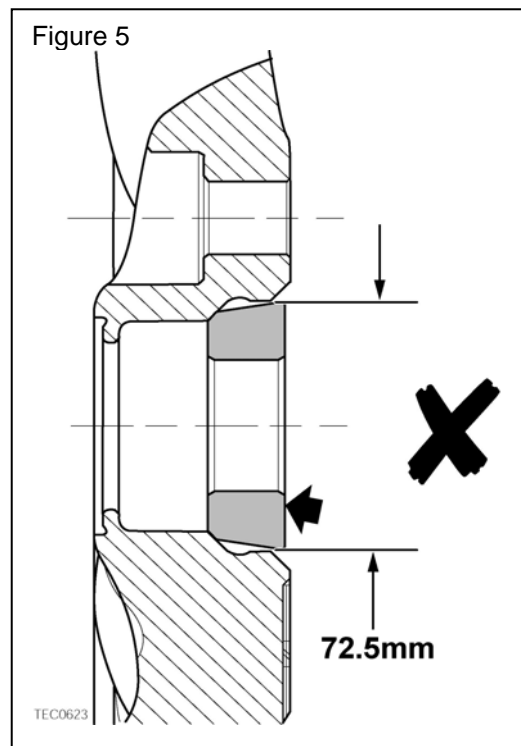
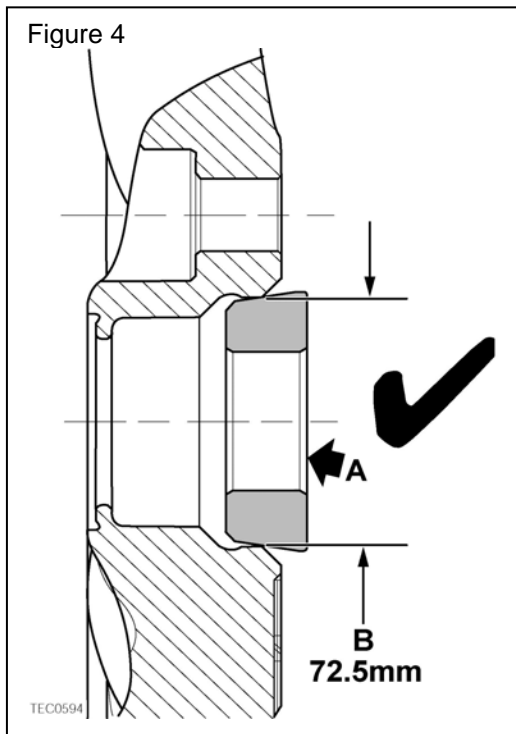
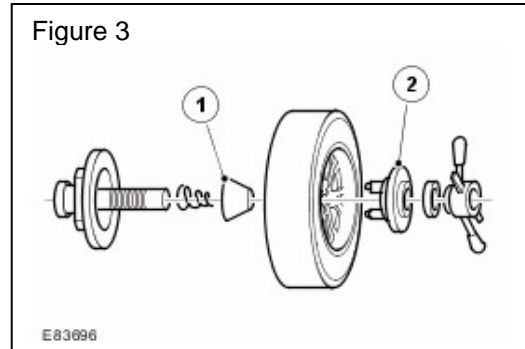

6. If these levels cannot be achieved, perform the following:
 - Remove the tire.
 - Follow the match mounting procedure as detailed by the Hunter machine.
 - Mark the high point of 1st harmonic RFV on the tire (ideally also mark on the inside too, as a future reference).
 - Install the lowest 1st harmonic RFV units to the front.
 - Print out the results of balance and force variation before and after, and attach to repair order.

NOTE: If RFV equipment is not available and the tire has not been removed from the wheel and the RFV spot (red dot) is still visible this, should be installed at the top.

7. The high-point of RFV should be marked, and the road wheel and tire assembly installed to the vehicle with the RFV high point at the top, prior to the wheels being tightened. (Figure 6)

NOTE: Nothing should be used to brace the wheel while tightening the nuts as this can disturb the match mounting.

8. Install all four road wheel and tire assemblies.
9. Tighten wheel nuts to **140Nm (103 lbf ft)**.
10. Lower the vehicle onto the lift.
11. Restore tire pressures to the recommended settings.
12. Drive the vehicle for approximately 7km (5 miles) carried out on normal roads and up to speeds of approximately 80 km/h (50 mph) to verify correction of steering vibration.

