

Parking Aid - Parking Aid

Description and Operation

Parking Aid Component Location

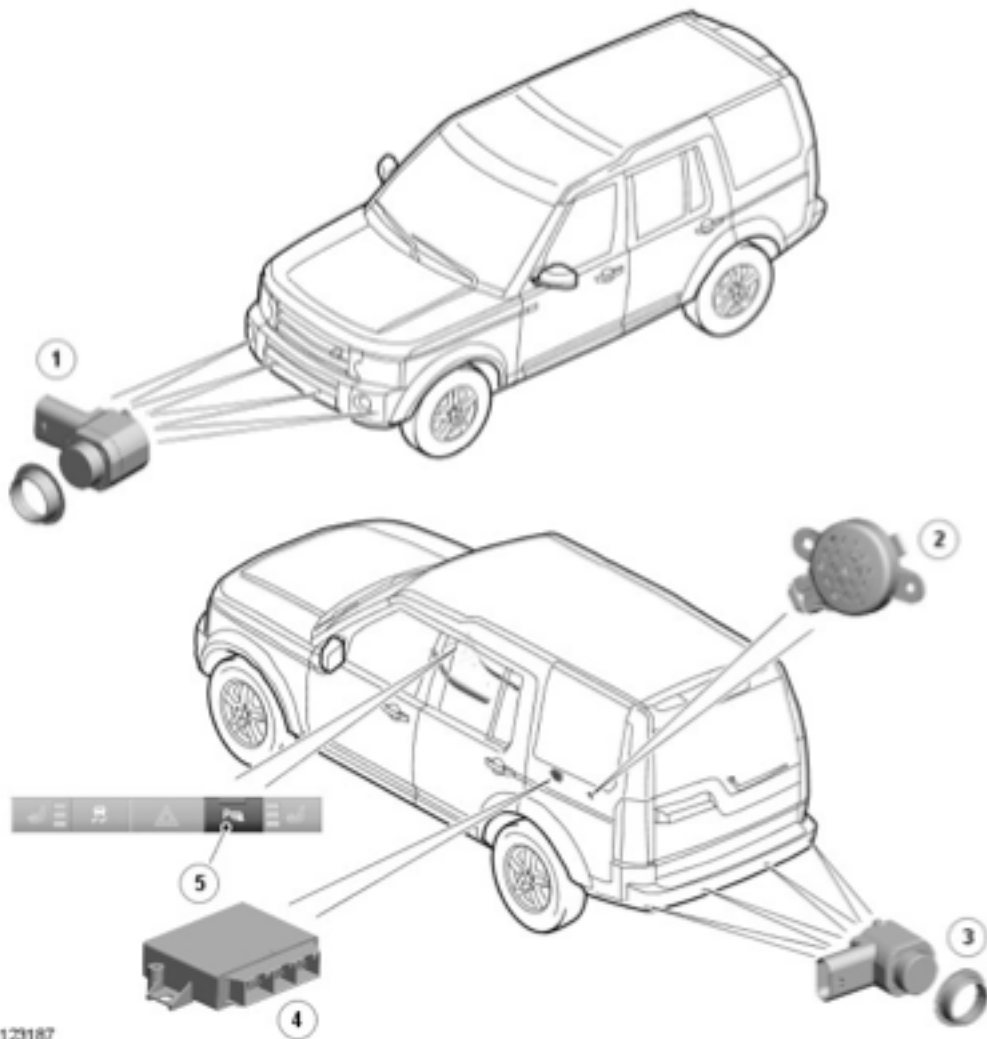

E 123187

Item	Part Number	Description
1	-	Front sensors
2	-	Parking aid sounder
3	-	Rear sensors
4	-	Parking aid module
5	-	Parking aid switch

OVERVIEW

A proximity camera system has been introduced as an optional fit. The system provides additional guidance to the driver when maneuvering at low-speeds and parking the vehicle. The proximity camera system is discussed in detail after the 'Parking Aid' section.

The camera system has also been developed to aid the driver when towing and reversing a trailer; refer to 'Tow Assist' for further information.

PARKING AID OVERVIEW

The parking aid provides an audible warning to the driver when any obstacles are in the path of the vehicle during a forward (if front sensors fitted) or reversing manoeuvre. The purpose of the system is to assist the driver when parking or

maneuvering in restricted space. It is not designed as a crash avoidance system or a replacement for visual interpretation by the driver.

The parking aid system is not standard on all vehicles and some vehicles may be fitted with rear sensors only. Higher specification vehicles may be fitted with both front and rear sensors.

The system comprises 4 ultrasonic sensors in the rear bumper, 4 ultrasonic sensors in the front bumper (if fitted), a control module, a fascia mounted control switch, a rear sounder unit and a front sounder unit (integral with the instrument cluster).

The system operates using ultrasonic signals which are transmitted by the sensors. The reflected echo from this output is received by the sensors and used by the parking aid module to calculate the distance from an object.

The fascia mounted switch allows the driver to deactivate the rear and front (if fitted) parking aid system, if operation is not required.

Parking Aid Module

The parking aid module is located in the rear left hand side of the luggage compartment, behind the side trim panel.

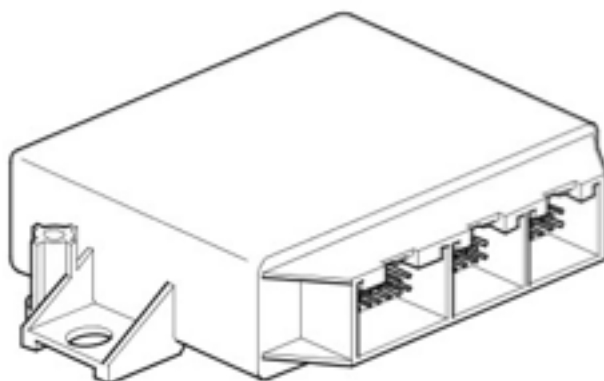

E44157

The parking aid module uses a single microprocessor to perform the following tasks:

- Control of the ultrasonic sensors
- Monitoring of the sensors
- Evaluation of received echo signals from the sensors
- Noise and disturbance suppression
- Control of the parking aid sounders
- Monitoring of the sounders and associated wiring
- Control and monitoring of the switch status LED (light emitting diode) and associated wiring
- Evaluation and monitoring of the control inputs
- Management of diagnostic and test functions
- Monitoring of power supply
- Communication via diagnostic link.

Inputs and Outputs

Three connectors on vehicles with front and rear sensors and two connectors on vehicles with rear sensors only provide the interface between the parking aid module and the external parking aid components.

The module receives inputs from the following:

- Reverse selected - CAN (controller area network) message from transmission control module (automatic transmission) or transfer box control module (manual transmission)
- Forward gear selected (not in reverse or neutral) - CAN message from transmission control module (automatic transmission) or transfer box control module (manual transmission)
- Parking aid switch
- Parking brake applied - CAN message
- Trailer fitted - CAN message for CJB (central junction box)
- Ignition - power supply

The module outputs signals to the following:

- Sensors - power and ground connections
- Sensors - digital signal - transmit and receive signals
- Rear sounder - varying frequency output
- Front sounder - CAN message to instrument cluster
- Parking aid switch - power supply for switch LED operation

Controller Area Network (CAN) Signals

The parking aid module sends and receives a number of digital signals via the medium speed CAN. The received signals are used for operation of the parking aid system.

The parking aid module receives the messages shown in the following table which are used to control the parking aid system.

Message	Transmitted by
Vehicle speed	ABS (anti-lock brake system) module
Selected gear position - Automatic transmission	Transmission control module
Selected gear position - Manual transmission	Transfer case control module
Electric park brake on/off	Electric park brake module
Vehicle movement status	ABS module
Trailer connected	CJB
Ambient temperature	ATC (automatic temperature control) module
Engine running status	Diesel engine control module
Stored odometer reading	Instrument cluster
Vehicle voltage level	Instrument cluster
Minute counter	Instrument cluster
Car configuration	Instrument cluster
Diagnostic physical request	A Land Rover approved diagnostic system via diagnostic socket
Diagnostic functional request	A Land Rover approved diagnostic system via diagnostic socket
Master configuration identification	Instrument cluster

Diagnostics

The parking aid module has a diagnostic connection via the medium speed CAN to enable faults to be retrieved using a Land Rover approved diagnostic system. Additionally, an on-board diagnostic routine within the parking aid module constantly monitors the system and alerts the driver to a system fault by emitting a tone from the front or rear sounder, depending on the fault.

If a parking aid system fault has occurred, the parking aid module will relay the occurrence of the fault to the driver in the following ways:

- The status LED will flash at a frequency of 2Hz if the system is active and fault is detected in the sensors, sounders, related wiring or the module.
- The front sounder will emit an error tone for 3 seconds at a frequency of 1500Hz if a fault is detected with the front sensors or the rear sounder develops a fault.
- The rear sounder will emit an error tone for 3 seconds at a frequency of 1500Hz if a fault is detected with the rear sensors, the switch, the LED in the switch or if there is a CAN bus error.

Sensors



E125149

Item	Part Number	Description
1	-	Front sensor housing
2	-	Front sensor
3	-	Rear sensor housing
4	-	Rear sensor

Four sensors are positioned in the rear bumper and the front bumper (if fitted). Each sensor housing has two raised location keys which locate in corresponding grooves in the bumper mounting hole and sets the correct orientation for the sensor bodies. The housings are clipped into the bumper from the front. The sensors are then clipped into the housings from the rear.

Each sensor has a three pin connector which connects into a common harness linking all four sensors. This harness is connected to the main vehicle body harness for the rear sensors or the engine compartment harness for the front sensors. The three pins are for sensor negative and positive feeds and a signal line.

Each sensor comprises a plastic housing which contains a piezoelectric disc. The disc resonates at a frequency of 38.4 kHz, producing an ultrasonic signal output. The disc also receives the reflected echo signal.

The parking aid module controls the operating mode of each sensor by the output of a digital signal on the signal line. Each sensor has two modes of operation; combined transmitter and receiver mode or receiver mode only.

In the combined mode, the sensor emits a series of ultrasonic impulses and then switches to receiver mode to receive the echo reflected by an obstacle in the detection range. These echo signals are amplified and converted from an analogue signal to a digital signal by the sensor. The digital signal is then transmitted to the parking aid module and compared with

preprogrammed data stored in an EEPROM (electrically erasable programmable read only memory) within the module. The module receives this data via the signal line from the sensor and calculates the distance to the obstacle according to the elapsed time between the transmitted and received impulse. The duration of the impulse transmission is determined by the module. The frequency of the impulse is determined by the sensor.

In the receiver mode, the sensor will receive impulses that were emitted by adjacent sensors. The module uses this information to precisely determine position and distance of the obstacle.

Parking Aid Switch



E 122823

The parking aid switch, located in the center console, is non-latching with an integral LED. The switch receives a 12V output to drive the LED when required. The switch is also connected to ground. When the switch is operated, the momentary completion of the ground is interpreted by the parking aid module as a signal to enable or disable the parking aid system.

Parking Aid Sounder

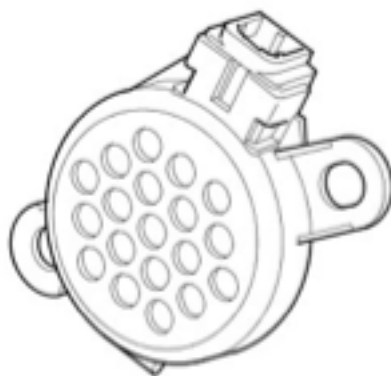

E44161

The parking aid sounder is controlled by the parking aid module and emits a series of tones of varying frequency to inform the driver of the distance between the vehicle and a detected object.

The rear parking aid sounder is located in the left-hand side of the luggage compartment, behind the side trim panel, below the window. The sounder is secured with two, self tapping screws into the body. The sounder is connected to the parking aid module via a harness connector.

The front parking aid uses the instrument cluster sounder and is activated by CAN messages from the parking aid module to the instrument cluster.

PARKING AID OPERATION AND DISTANCE CALCULATION

On vehicles with rear only parking aid sensors, when reverse gear is selected, the parking aid sensors are automatically activated. The parking aid module only activates the system if reverse is selected for more than 1 second. This avoids nuisance audible warnings when the gear selector lever is being moved between Drive and Park.

When the rear system is activated, the parking aid module illuminates the indicator LED in the parking aid switch, switches on the ultrasonic sensors and generates a single chime on the parking aid sounder to indicate the system is active. If an object is in the range of the sensors when the system is activated, a series of audible warnings are emitted by the parking aid sounder immediately.

If parking aid operation is not required, it can be suspended temporarily by pressing the parking aid switch. On vehicles with rear only parking aid sensors, the system can be enabled again by pressing the switch again or switching the ignition

'off' then 'on'. The parking aid will then automatically become active again in reverse gear. The system also remains on when going from reverse gear to neutral. The assumption being that the driver may still want to manoeuvre the vehicle going backwards in neutral.

The parking aid module receives a signal on the CAN from the CJB when a trailer is fitted. When this signal is detected, the parking aid module suspends operation of the rear parking aid sensors.

On vehicles with front and rear systems, the front system is activated when the ignition is 'on', the vehicle is out of Park and the EPB (electronic parking brake) is off. If the vehicle speed subsequently goes above approximately 10 mph (16 km/h), the front system will switch off. When the speed drops below approximately 6 mph (10 km/h), the front system activates again. If the EPB is applied or Park is selected, the Parking Aid system is deactivated.

Sensor Operation

The parking aid module processes the distance readings from the ultrasonic sensors to determine if there are any objects within the detection areas. If there are no objects in the detection areas, there are no further audible warnings. If an object is detected, repeated audible warnings are produced on the parking aid sounder.

The maximum detection range is 1800 mm (70 in). When an object is detected, the time delay between the audible warning tones decreases as the distance between the detected object and the vehicle decreases until, at approximately 350 mm (13.7 in), the audible warning tone is continuous.

After the initial detection of an object, if there is no decrease in the distance between an object and the central sensors, the time delay between the audible warnings remains constant. If an object is detected by one of the corner sensors only, the audible warnings stop after about 5 seconds if there is no change in the distance between the object and the corner sensor.

Detection Area

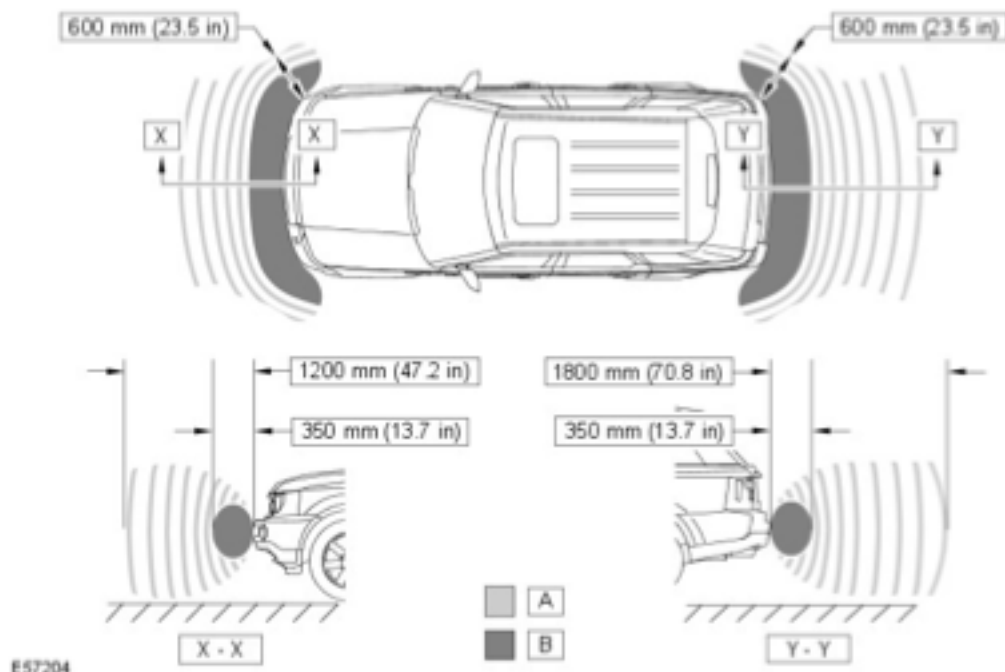

E57204

Item	Part Number	Description
A	-	Intermittent Warning Tone
B	-	Continuous Warning Tone

Detection Calculation

When operating in the combined transmitter and receiver mode, the sensor outputs a number of ultrasonic pulses and receives the reflected echo signal. The parking aid module amplifies the received echo signals and compares them with a preprogrammed threshold to calculate the distance to the object. This is achieved by determining the elapsed time between the transmission and reception of the ultrasonic signal.

When operating in receiver mode, the sensor receives echo signals transmitted by an adjacent sensor. This mode is used to improve the accuracy of the system.

The detection cycle consists of the parking aid module operating one sensor in the combined transmitter and receiver mode and transmitting a number of ultrasonic pulses. The module then switches the transmitting sensor and the adjacent sensor(s) to receiver mode. After a short time delay, this sequence is repeated using a different sensor to transmit the ultrasonic pulse and continues until all four sensors have output an ultrasonic signal. This sequence is completed in 100ms. The module uses several measurements of the same sensors to remove errors from the calculation.

If the object is directly behind a sensor, the distance is calculated using the time between the transmission and reception of the signal. If the object is positioned between two sensors, the parking aid module uses both signals to determine the correct distance using triangulation.

To perform the triangulation calculation, the parking aid module must know the distance between the individual sensors in the bumper. This information is stored in the module memory. From the received distance from each sensor and using the known distance between adjacent sensors, the module can calculate the minimum distance from the vehicle to the object.

When approaching several objects, the module recognizes the distance from the vehicle to the nearest object.

CONTROL DIAGRAM

• NOTE: A = Hardwired; D = High Speed CAN Bus; N = Medium Speed CAN Bus

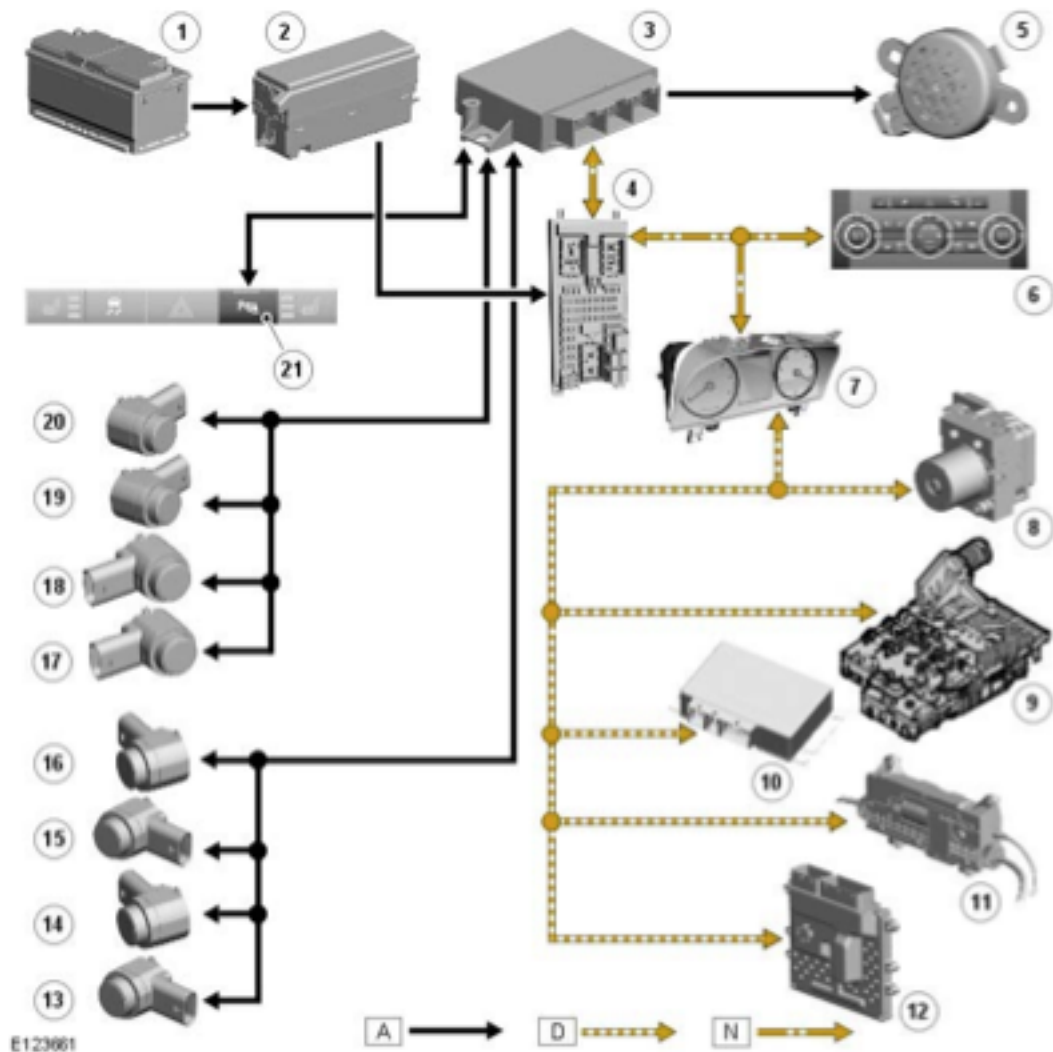

Item	Part Number	Description
1	-	Battery
2	-	Battery Junction Box (B/B)
3	-	Parking aid module
4	-	Central Junction Box (CJB)
5	-	Rear parking aid sounder
6	-	Automatic Temperature Control (ATC) module
7	-	Instrument cluster
8	-	ABS module
9	-	Transmission control module
10	-	Transfer box control module
11	-	Electric park brake module

12	-	Engine control module
13	-	Left outer front sensor
14	-	Left inner front sensor
15	-	Right inner front sensor
16	-	Right outer front sensor
17	-	Left outer rear sensor
18	-	Left inner rear sensor
19	-	Right inner rear sensor
20	-	Right outer rear sensor
21	-	Parking aid switch

PROXIMITY CAMERA SYSTEM