

Lower Arm Bushing (60.35.33)

Special Service Tools

204-536/1



Receiver front lower arm front bush
204-536/1

204-536/2



Remover front lower arm front bush
204-536/2

204-536/3



Installer front lower arm front bush
204-536/3

205-754

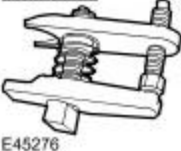

Ball joint separator
205-754 (LRT-54-027)

204-506/1



Halfshaft remover/replacer
204-506/1 (LRT-60-030/1)



Halfshaft remover/replacer
204-506/3 (LRT-60-030/3)



Retainers - halfshaft remover/replacer
204-506/5 (LRT-60-030/5)



Receiver lower arm rear bush
204-535/1



Remover lower arm rear bush
204-535/2



Remover plate lower arm rear bush
204-535/4



Installer lower arm rear bush

204-535/3

204-535/5



Installer/depth setter lower arm rear bush
204-535/5

Removal

NOTE:

The bushings must be replaced in pairs, LH and RH sides.

NOTE:

Take note of the fitted position of the bush.

1.



WARNING: Do not work on or under a vehicle supported only by a jack. Always support the vehicle on safety stands.

Raise and support the vehicle.

2.

Remove the wheels and tires.

3.

Remove the RH lower arm. For additional information, refer to [Lower Arm \(60.35.02\)](#) (Section 204-01)

4.

Remove the halfshaft retaining nut.

▶ Discard the nut.

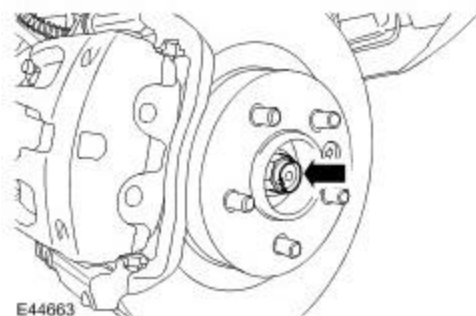

5.



CAUTION: Use a wrench on the hexagon provided to prevent the ball joint rotating.

Disconnect the LH stabilizer bar link.

▶ Remove and discard the nut.

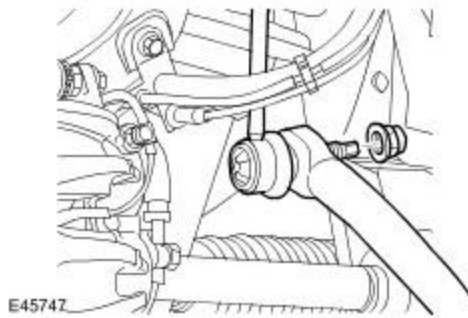

6. Release the brake hose bracket from the wheel knuckle.

▶ Remove the bolt.

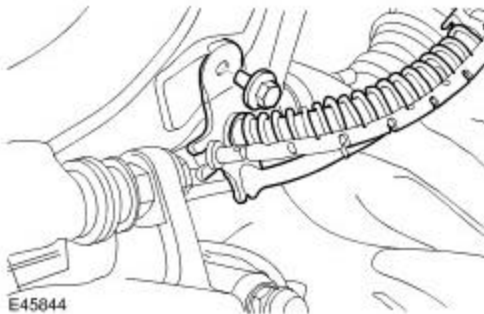

7. Loosen the tie-rod end ball joint retaining nut.

8.  **CAUTION: Ensure the ball joint seal is not damaged. A damaged seal will lead to the premature failure of the joint.**

Using the special tool, release the tie-rod end ball joint from the wheel knuckle.

▶ Discard the nut.

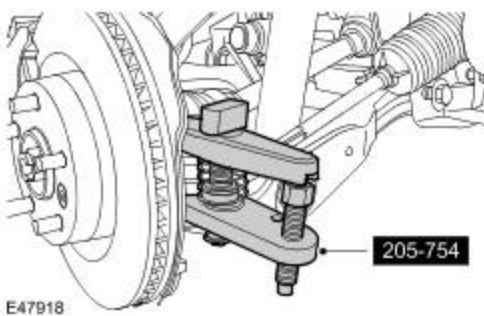

9.  **CAUTION: To prevent the wheel knuckle falling outwards and disconnection of the halfshaft inner joint, support the wheel knuckle.**

Loosen the upper arm retaining nut.

- 10.



CAUTION: Ensure the ball joint seal is not damaged. A damaged seal will lead to the premature failure of the joint.

Using the special tool, release the upper arm ball joint.

➤ Remove and discard the retaining nut.

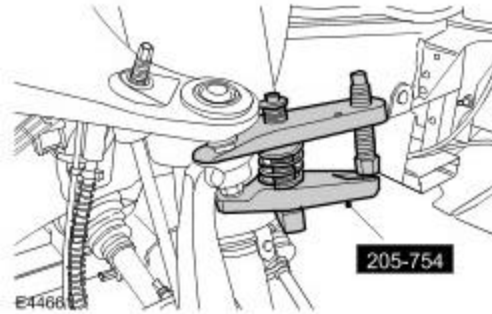

11. Using the special tools, release the halfshaft from the wheel hub.

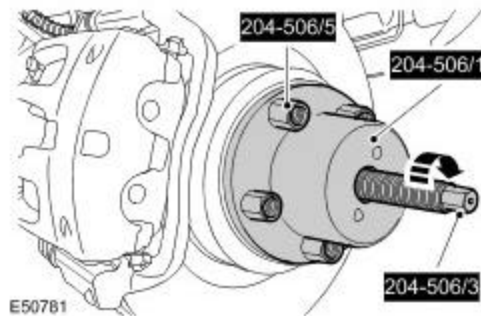

12. Release the halfshaft from the wheel knuckle.

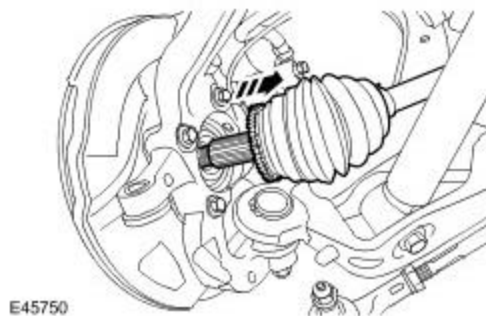

13. Secure the halfshaft clear of the lower arm.
14. Remove the lower ball joint retaining nut.
15. Using the special tool, release the lower ball joint from the steering knuckle.

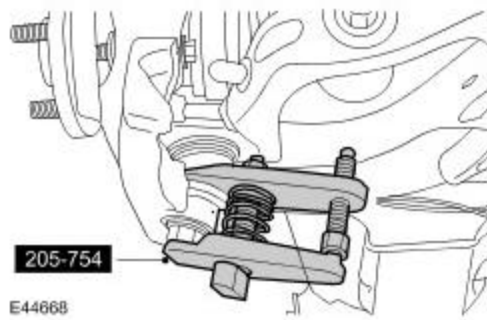

- 16 . Loosen the 2 lower arm bolts.
 - ▶ Mark the position of the bolts in relation to the chassis brackets.
- 17 . Disconnect the shock absorber and spring assembly from the lower arm.
 - ▶ Remove the retaining bolt.
- 18 . Remove the LH lower arm.

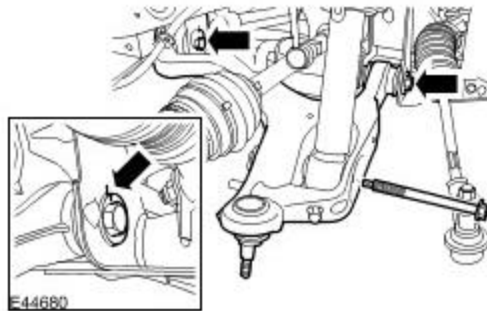

- 19 . Note the position of the bushing in relation to the lower arm.

- 20 .  **CAUTION: The bush flanges need to be removed to allow bush removal.**

Remove the lower arm front bushing flanges.

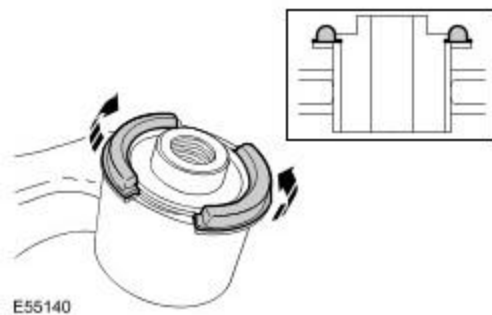

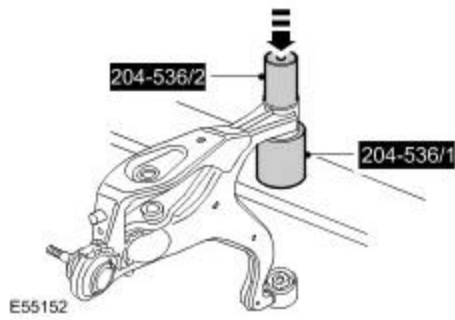

- 21 . Using the special tools, remove and discard the lower arm front bushings.

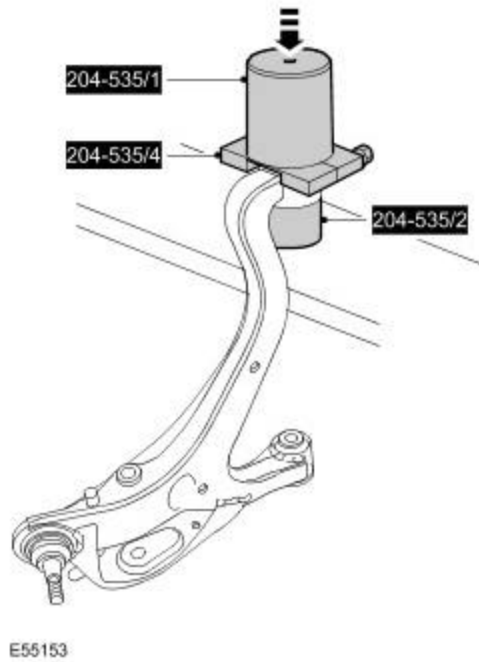

- 22 . Using the special tools, remove and discard the lower arm rear bushings.



Installation

1.  **CAUTION: Make sure the bush is correctly aligned.**
 **CAUTION: Make sure the correct special tool is used to install the bushings to the correct depth.**

Using the special tools, install the lower arm rear bushings.

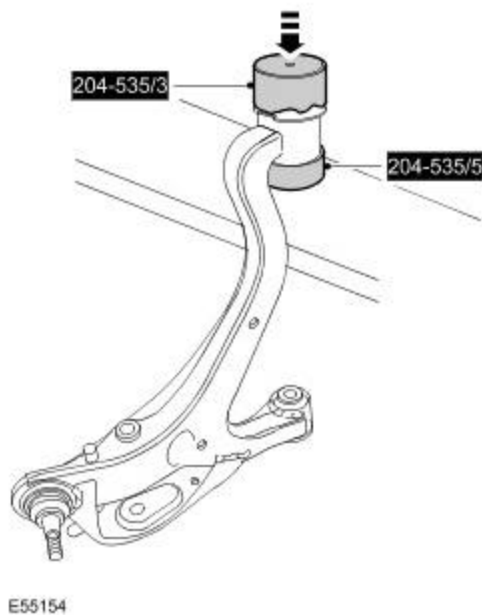

2.  **CAUTION: Make sure the bush is correctly aligned.**

Using the special tools, install the lower arm front bushings

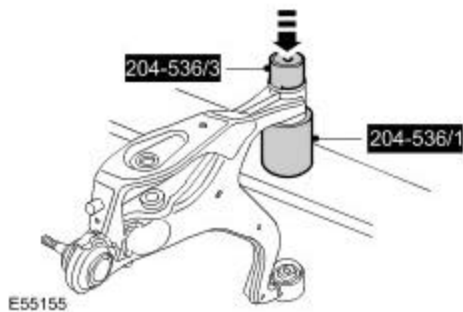

3. Install the LH lower arm.
▶ Fit the bolts but do not fully tighten at this stage.
4. Connect the shock absorber and spring assembly to the lower arm.
▶ Tighten the nut and bolt to 300 Nm (221 lb.ft).
5. Release the halfshaft.
6. Using the special tools, install the halfshaft in the wheel hub.

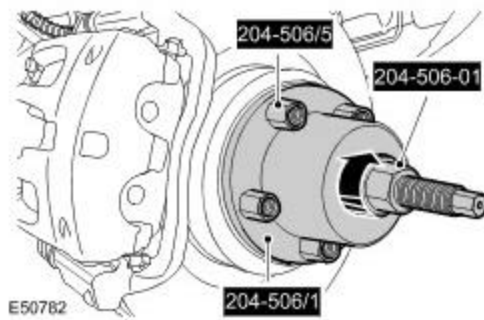

7. Connect the upper arm and wheel knuckle.
 - ▶ Install a new nut and tighten to 70 Nm (52 lb.ft).
8. Secure the stabilizer bar link.
 - ▶ Tighten the nut to 115 Nm (85 lb.ft).
9. Connect the tie-rod end ball joint.
 - ▶ Install a new nut and tighten to 70 Nm (52 lb.ft).
10. Install a new halfshaft retaining nut and lightly tighten.
11. Secure the brake hose retaining bracket to the wheel knuckle.
 - ▶ Tighten the bolt to 25 Nm (18 lb.ft).
12. Secure the LH stabilizer link.
 - ▶ Tighten the nut to 115 Nm (85 lb.ft).
13. Tighten the halfshaft retaining nut to 350 Nm (258 lb.ft).
 - ▶ Stake the nut to the halfshaft.
14. Set the height distance between the centre of the halfshaft end and the edge of the fender trim to 466 mm (18.34").

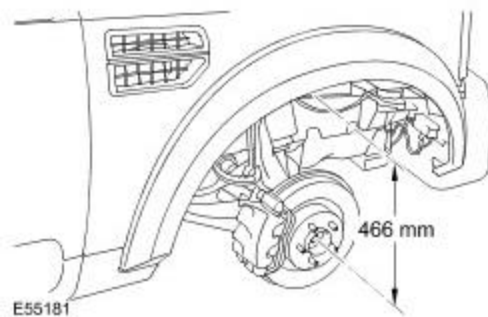

15. Tighten the lower arm bolts to 275 Nm (203 lb.ft).
 - ▶ Align the bolts to the marks made previously.
16. Install the RH lower arm. For additional information, refer to [Lower Arm \(60.35.02\)](#) (Section 204-01)

- 17 . Install the wheels and tires.
 - ▶ Tighten the wheel nuts to 140 Nm (103 lb.ft).
- 18 . Carry out the wheel alignment procedure.